



HAL
open science

EvoLVE: Smart charging at CEA

Bruno Robisson, Sylvain Guillemin, Gérald Vignal, Alexandre Mignonac

► **To cite this version:**

Bruno Robisson, Sylvain Guillemin, Gérald Vignal, Alexandre Mignonac. EvoLVE: Smart charging at CEA. NEEMO SCHOOL-1: e-Mobility on Islands, MCAST, Mar 2021, Saint-Paul Lez Durance, France. cea-03210974v2

HAL Id: cea-03210974

<https://cea.hal.science/cea-03210974v2>

Submitted on 5 May 2022

HAL is a multi-disciplinary open access archive for the deposit and dissemination of scientific research documents, whether they are published or not. The documents may come from teaching and research institutions in France or abroad, or from public or private research centers.

L'archive ouverte pluridisciplinaire **HAL**, est destinée au dépôt et à la diffusion de documents scientifiques de niveau recherche, publiés ou non, émanant des établissements d'enseignement et de recherche français ou étrangers, des laboratoires publics ou privés.



Networking for Excellence in Electric Mobility Operations

www.NEEMO-project.eu
@NEEMOproject

SCHOOL



NEEMO SCHOOL-1: e-Mobility on Islands

EVOLVE: SMART CHARGING AT CEA



Bruno Robisson*, Sylvain Guillemain*, Gérald Vignal†, Alexandre Mignonac*
*CEA Cadarache
†RTE

Tuesday 16 March 2021, 16:00-18:00 (UTC+1)



The project has received funding from the European Union's Horizon 2020 research and innovation programme under grant agreement No 857484

- **EvoIVE Project**
- **CEA EVCI & PV**
 - CEA EVCI
 - Charging modes
 - EvoIVE @INES
 - EvoIVE @Cadarache
- **Transaction analysis**
 - Transactions
 - Energy Consumption v. Transaction Duration (EC v. TD)
 - Flexibility definition & estimation
 - Beginning / end of transactions
- **Load curves**
 - Reconstruction
 - Analysis
- **Smart charging**
 - IT infrastructure
 - Autoconsumption rate
 - Examples of simulation results
 - First experimental results

Partners

RTE : Réseau de Transport d'Electricité

CEA: Commissariat à l'Energie Atomique et aux Energies Alternatives

Objective

This project aims to synchronize the charge of a fleet of EVs with an “off-site” photovoltaic production.

Tasks

1. Defining the experimental framework
2. Design and setup equipments, IT infrastructure and control algorithms
3. Monitor and evaluate the experiments

Planning

Kick-off: January 2020

Tasks 1 & 2 : 01/2020 -> 05/2021

Task 3 : 06/2021 -> 05/2022

- **EvoIVE Project**
- **CEA EVCI & PV**
 - CEA EVCI
 - Charging modes
 - EvoIVE @INES
 - EvoIVE @Cadarache
- **Transaction analysis**
 - Transactions
 - Energy Consumption v. Transaction Duration (EC v. TD)
 - Flexibility definition & estimation
 - Beginning / end of transactions
- **Load curves**
 - Reconstruction
 - Analysis
- **Smart charging**
 - IT infrastructure
 - Autoconsumption rate
 - Examples of simulation results
 - First experimental results

- Civil centers
- Military centers
- INES Chambéry
- Technological platforms

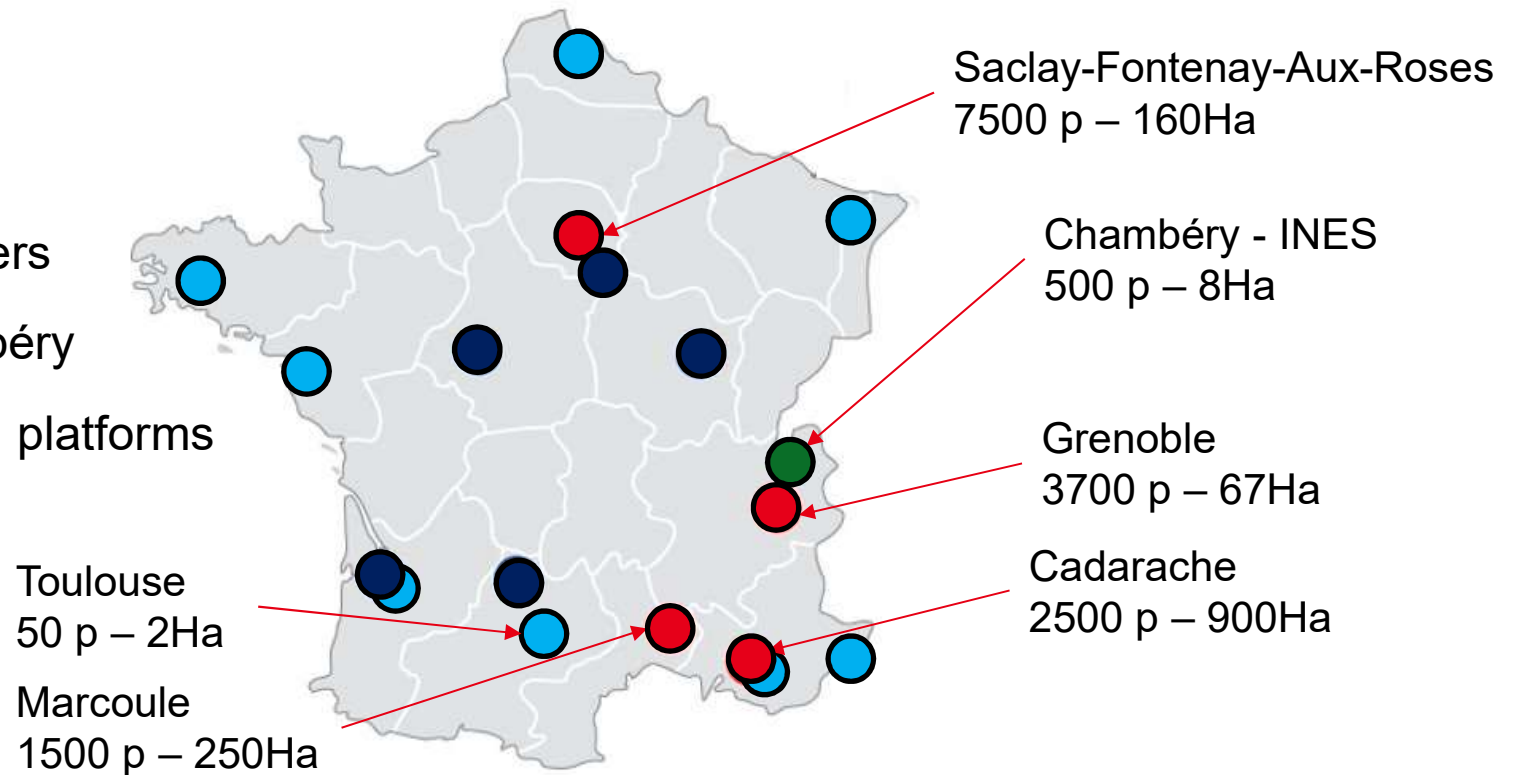

- **9** research centers (5 civil / 4 military)
- **8** technological platforms
- **20 181** employees (included 1 233 PhD students and 176 postdoctoral researchers)
- Budget of **5 billion** euros

CEA : ELECTRIC VEHICLES CHARGING INFRASTRUCTURE (EVCI)



INES

Toulouse

Grenoble

Cadarache

Normal	<11kW
Accelerated	>11kW & <24kW
Fast	>24kW

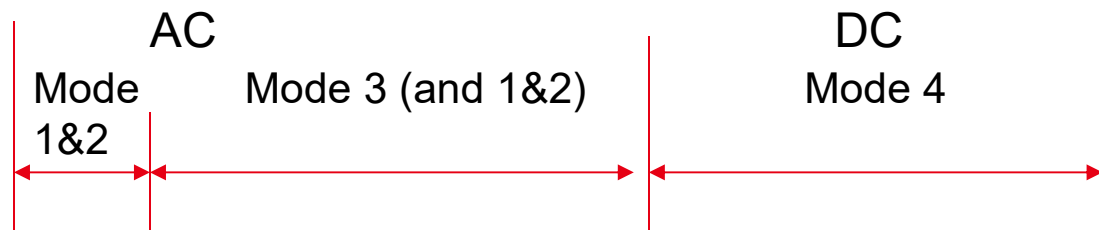

CEA employees	Surface (Ha)	Center		AC				DC			TOTAL	
				3kW AC	7kW AC	11kW AC	22kW AC	10kW DC	30kW DC	50kW DC		
2500	900	Cadarache					81				81	
50	2	Toulouse	Actual				3				3	
			Forecast		4		2	1		2	9	
7500	160	Saclay			40						40	
500	8	Ines					20		1		21	
3700	67	Grenoble		70	51		4				125	
1500	250	Marcoule		22		16					38	
		TOTAL			92	95	16	110	1	1	2	317

CHARGING MODE (IEC 61851 STANDARD)

On board charging, also called « **AC charging** »
From 3kW to 22kW (and even 43kW for Zoé first generation)

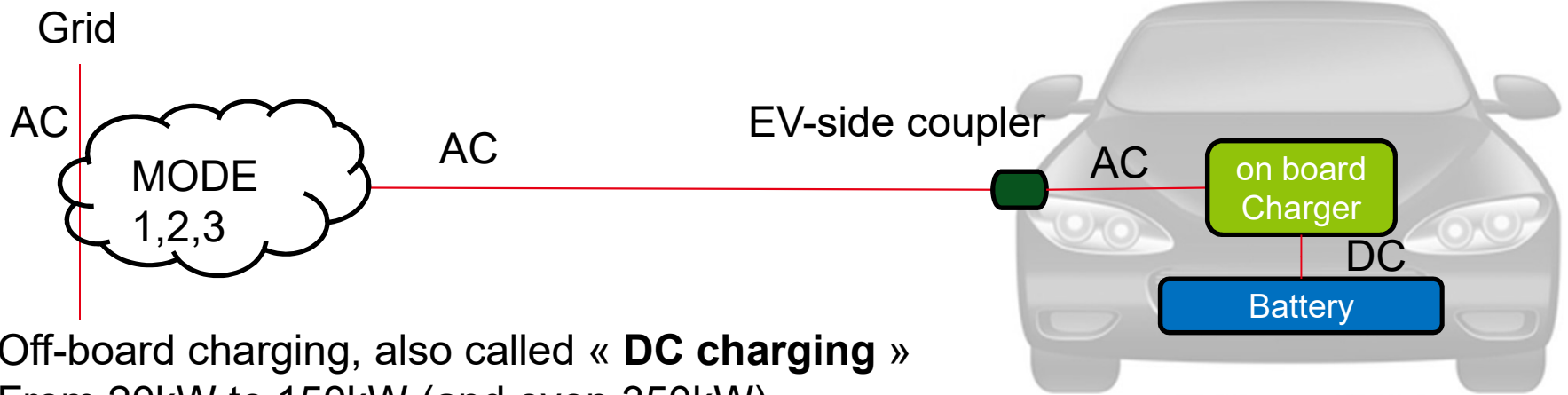

Off-board charging, also called « **DC charging** »
From 20kW to 150kW (and even 350kW)

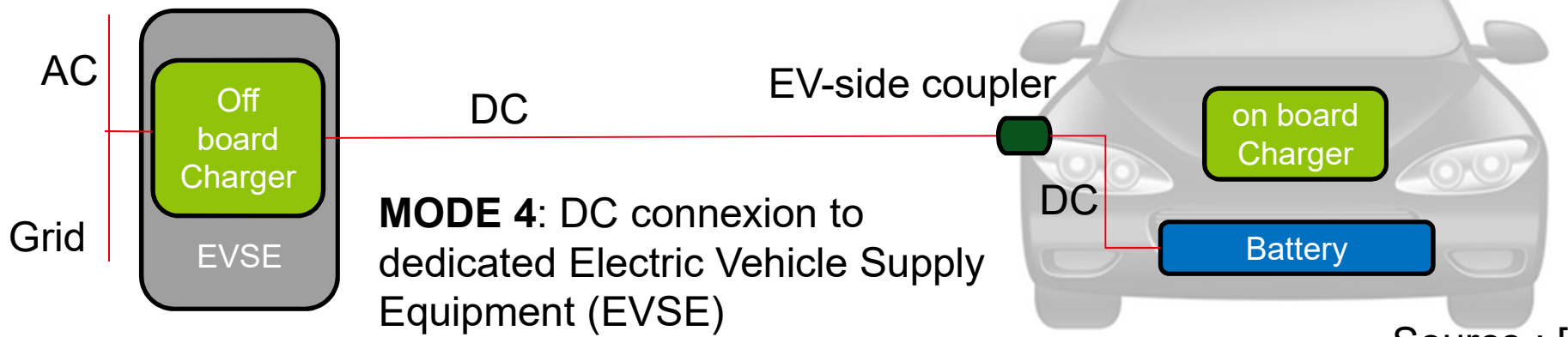

MODE 4: DC connexion to dedicated Electric Vehicle Supply Equipment (EVSE)

Source : [1]

AC CHARGING MODE: MODE 1, 2

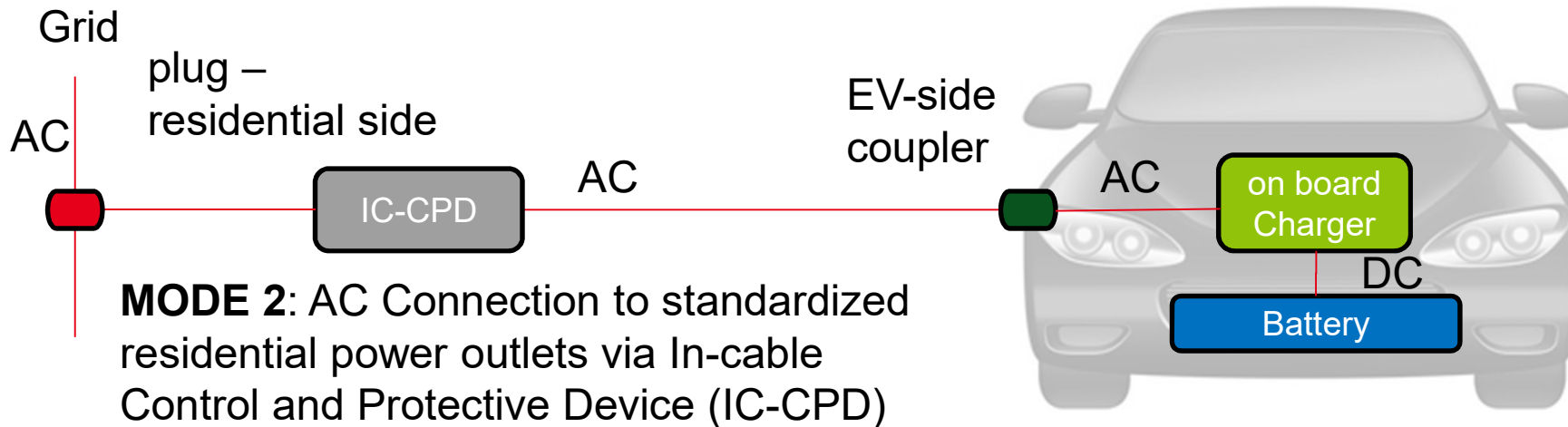
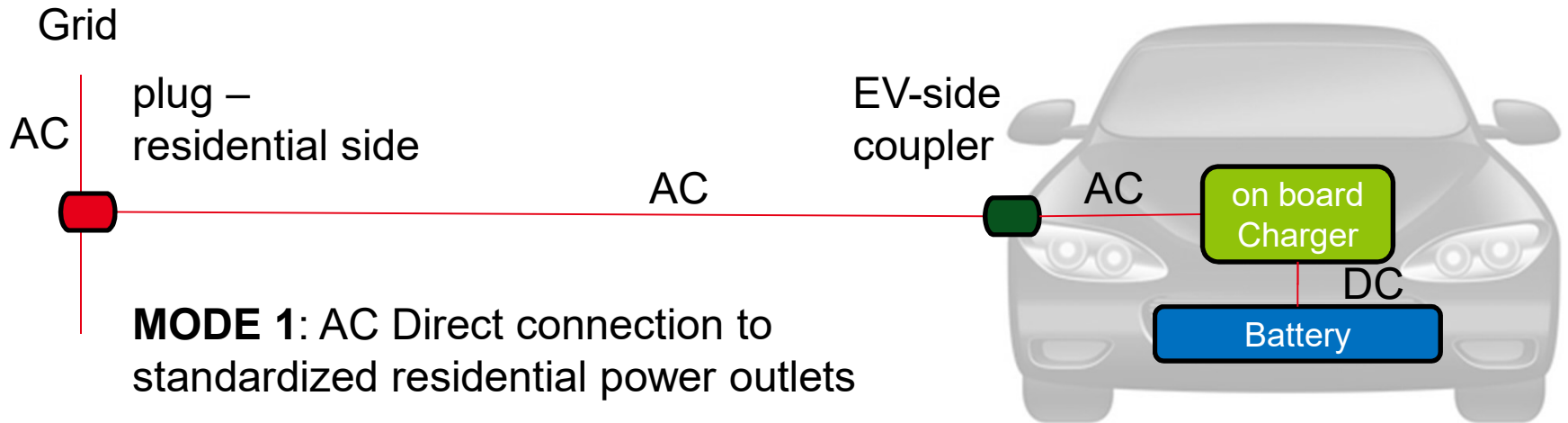

Source : [1]

THE PLUG AND SOCKET ZOO – MODE 2



Type E (CEE 7/17) Mono-p
230V
70@Grenoble
22@Marcoule



Blue: « camping »
socket Mono-p
230V



Red: Industrial socket
Tri-p 400V



Tesla coupler

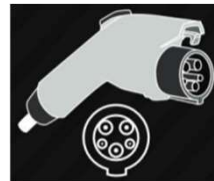

Type 1 coupler



Type 2 coupler

Depends on the vehicle

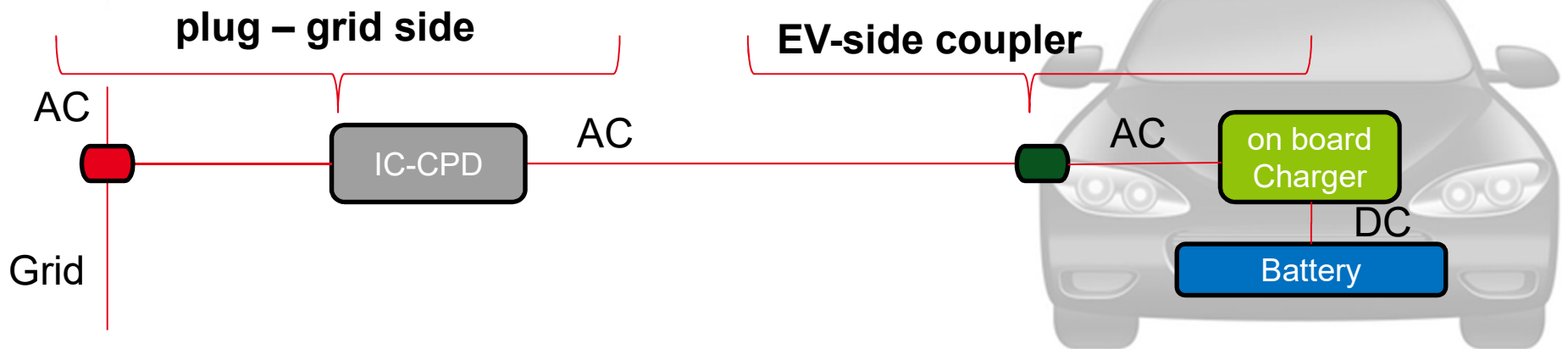

AC CHARGING MODE: MODE 3

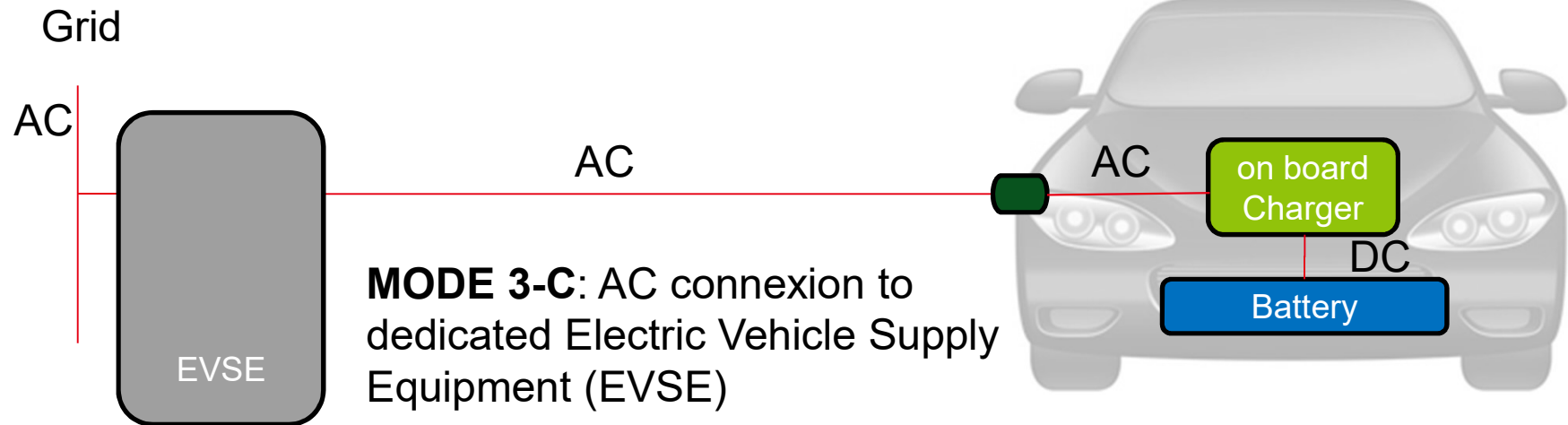
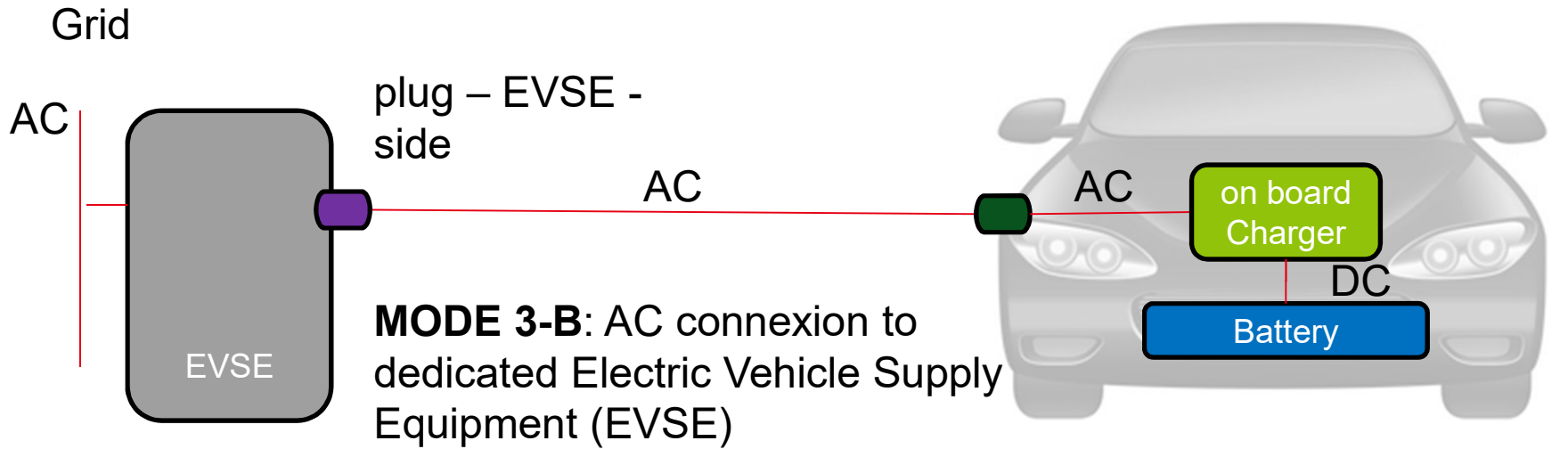

Source : [1]

THE PLUG AND SOCKET ZOO – MODE 3 B



Type 2 outlet

7@Toulouse
42@Grenoble
18@INES
40@Saclay
81@Cadarache
16@Marcoule



Type 3 outlet

9@Grenoble

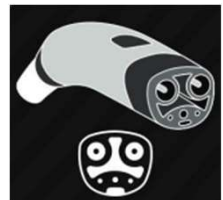

Tesla coupler



Type 1 coupler



Type 2 coupler

Depends on the vehicle

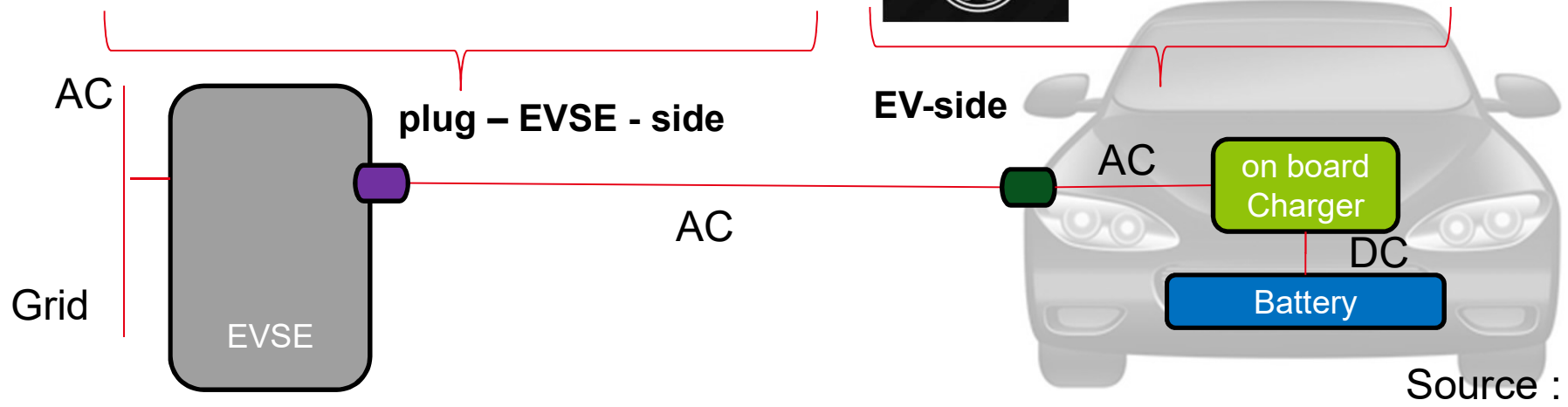

Source : [1,2]

THE PLUG AND SOCKET ZOO – MODE 3 C

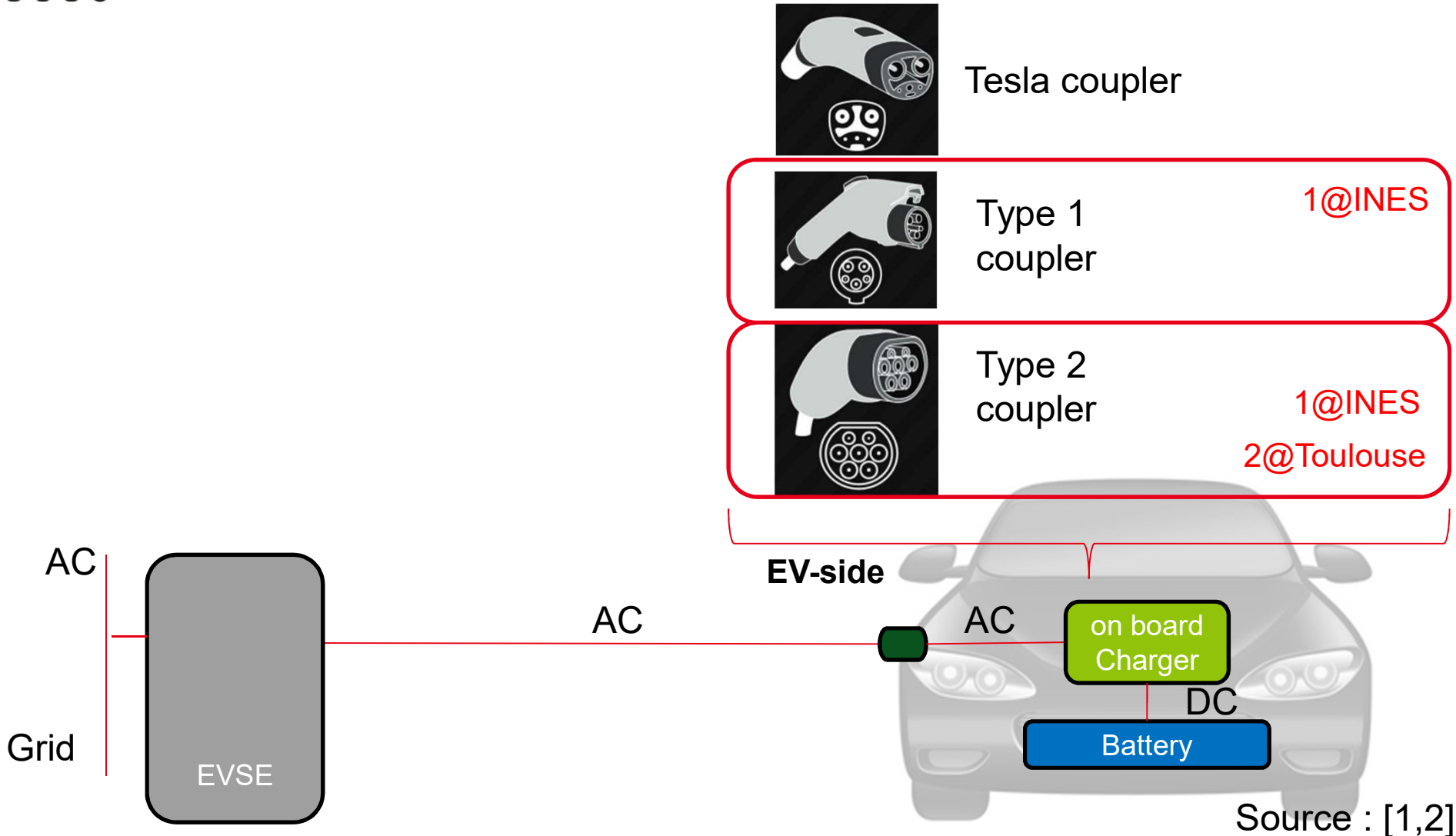

THE PLUG AND SOCKET ZOO – MODE 4



Tesla plug



CHAdeMO
(DC only)

2@Toulouse
1@INES



Combo 2 : Combined
Charge System CCS
(DC+type 2)

1@Toulouse

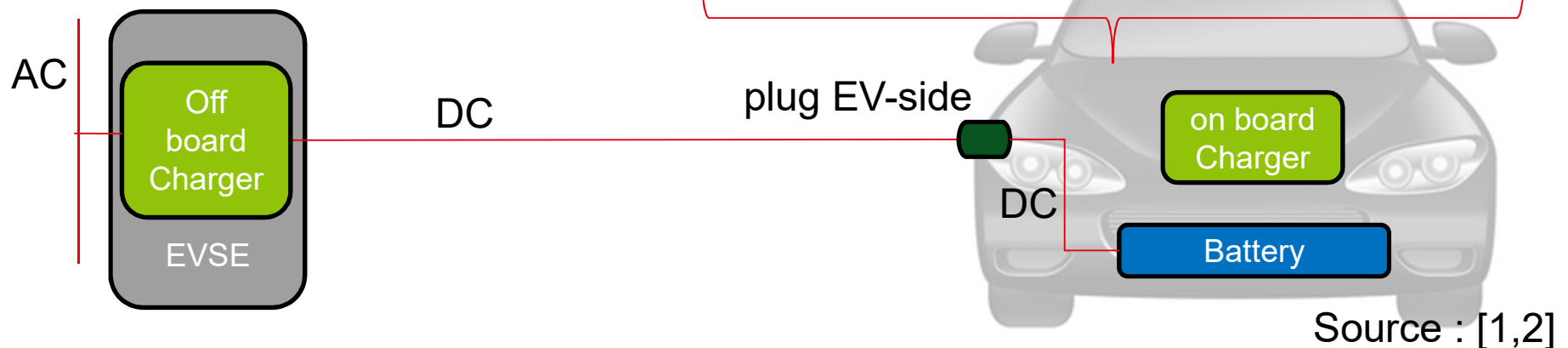

ELECTRIC VEHICLE CHARGING INFRASTRUCTURE (EVCI)

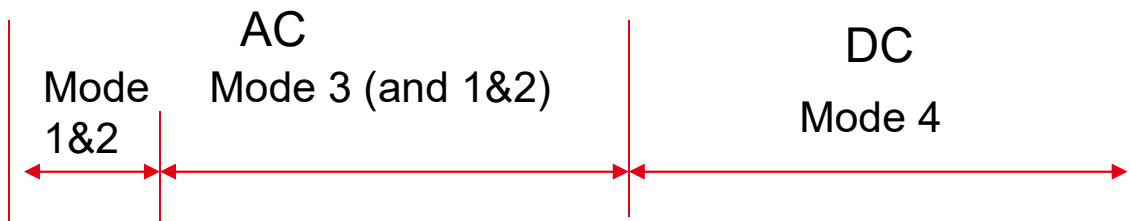

CEA employees	Surface (Ha)	Center	AC				DC			TOTAL	
			3kW AC	7kW AC	11kW AC	22kW AC	10kW DC	30kW DC	50kW DC		
2500	900	Cadarache	81							81	
50	2	Toulouse	Actual			3				3	
			Forecast		4	2	1		2	9	
7500	160	Saclay		40					40		
500	8	Ines	20					1		21	
3700	67	Grenoble	70	51		4			125		
1500	250	Marcoule	22		16				38		
		TOTAL		92	95	16	110	1	1	2	317

EvoIVE

→ 1/4 of the 81 AC-EVSE in INES : 20 EVSE

→ 100% of the 20 AC-EVSE in Cadarache : ~ 20 EVSE

➔ INES + CADARACHE = 40 * 22kW AC mode 3 (and mode 1&2)

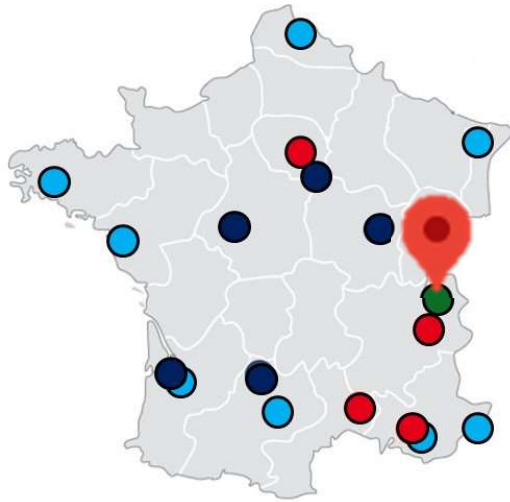

INES research center @Chambéry



- 20 parking places
- 12 of them are above a 21kWp solar carpot
- 10-15 EV users

9 e-totem
 (e-smart
 1*22kW)

3 Driveco
 (Kino One
 1*22kW)

2 Driveco
 (Kino One
 2*22kW)

1 Hager
 (Witty Park
 2*22kW)

1 Cahors
 (Access
 2*22kW)



Mode 3B



Mode 3B



Mode 3B & 3C



Mode 3B



Mode 3B

20 * 22kW EVSE

CEA CADARACHE – NEAR AIX-EN-PROVENCE



5500 workers

1600 Ha **900ha** fenced (22 km of fence)

480 buildings and **500 000** m2 de planchers

70 Km of paved roads, 6 km of landscaped footpath, around 5500 people / day on site

29 Bus lines carrying a thousand employees

75 km of water distribution network (drinking water station, industrial water, purification station)

Private power network

- 63kV / 15kV substation
- 18 MV loops (85km of 15kV underground lines)
- EVCI : 81 charging points at 22kVA
- 3kV public lighting network



63kV / 15kV substation

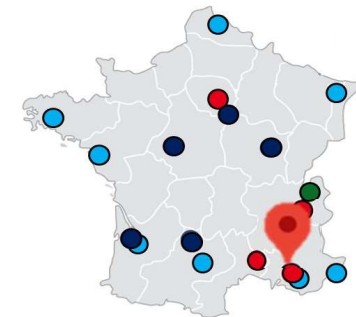

CEA CADARACHE – SOLAR R&D

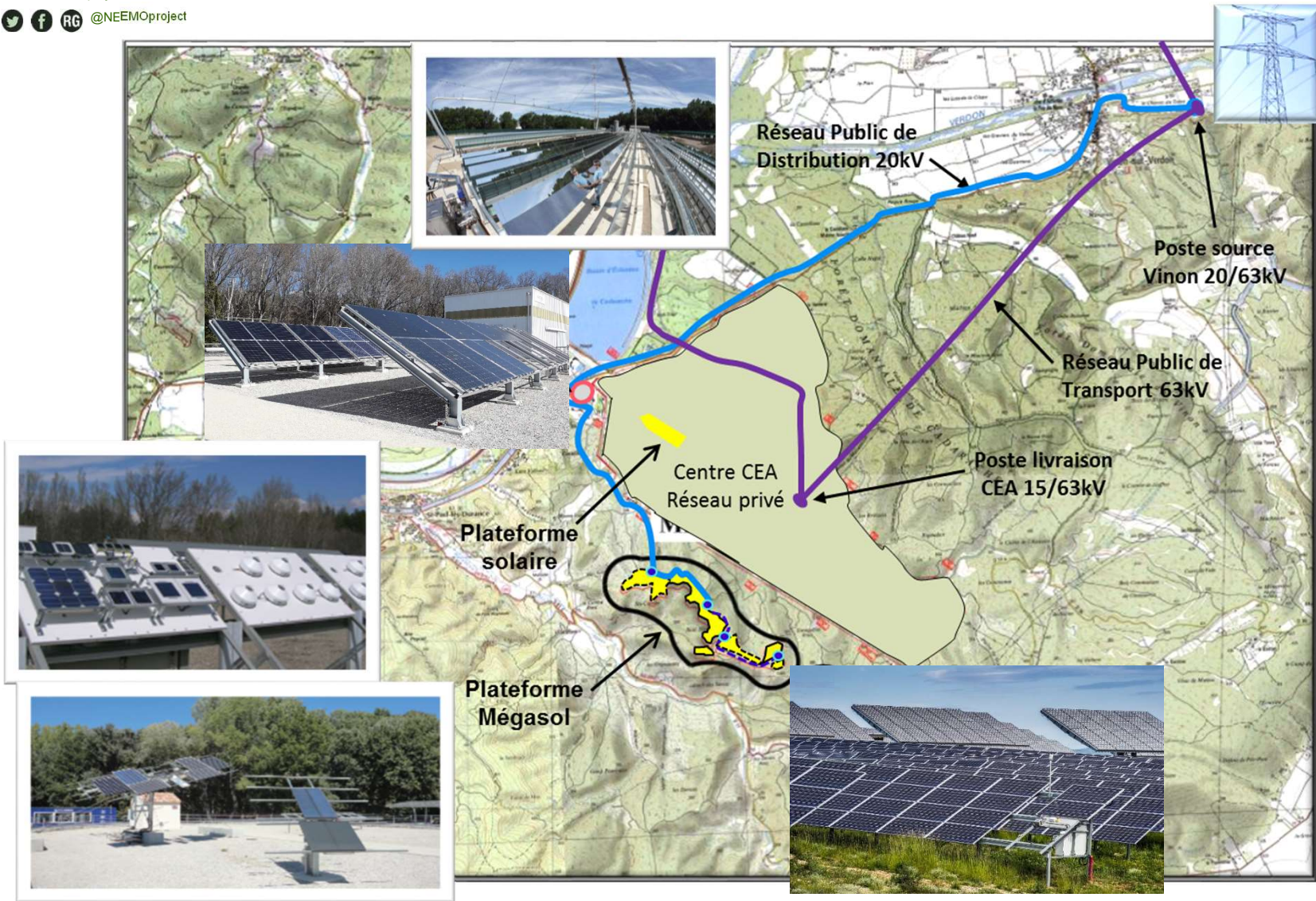

MÉGASOL PLATFORM (13 MWP)

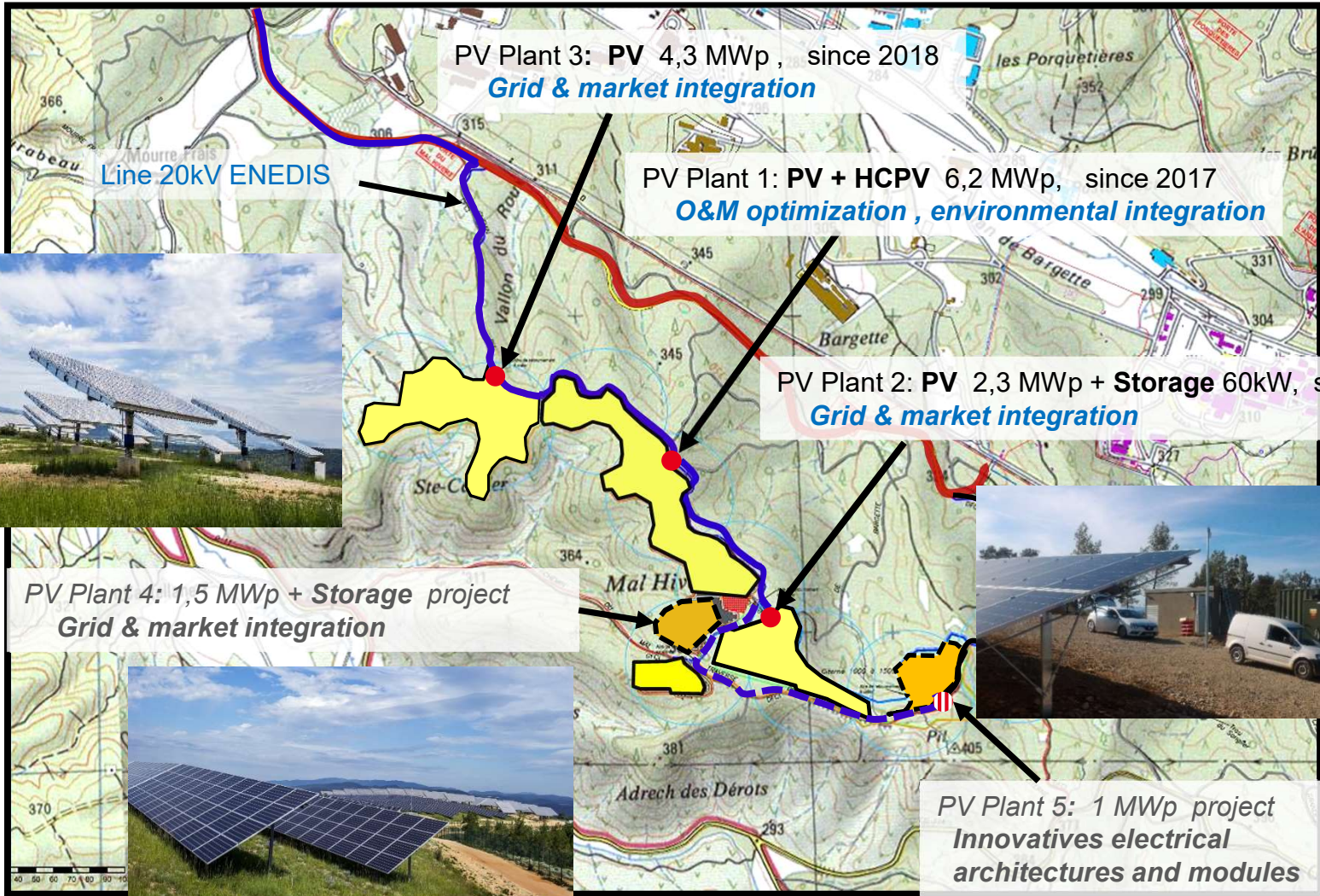

EVCI CADARACHE – CHARGING STATION

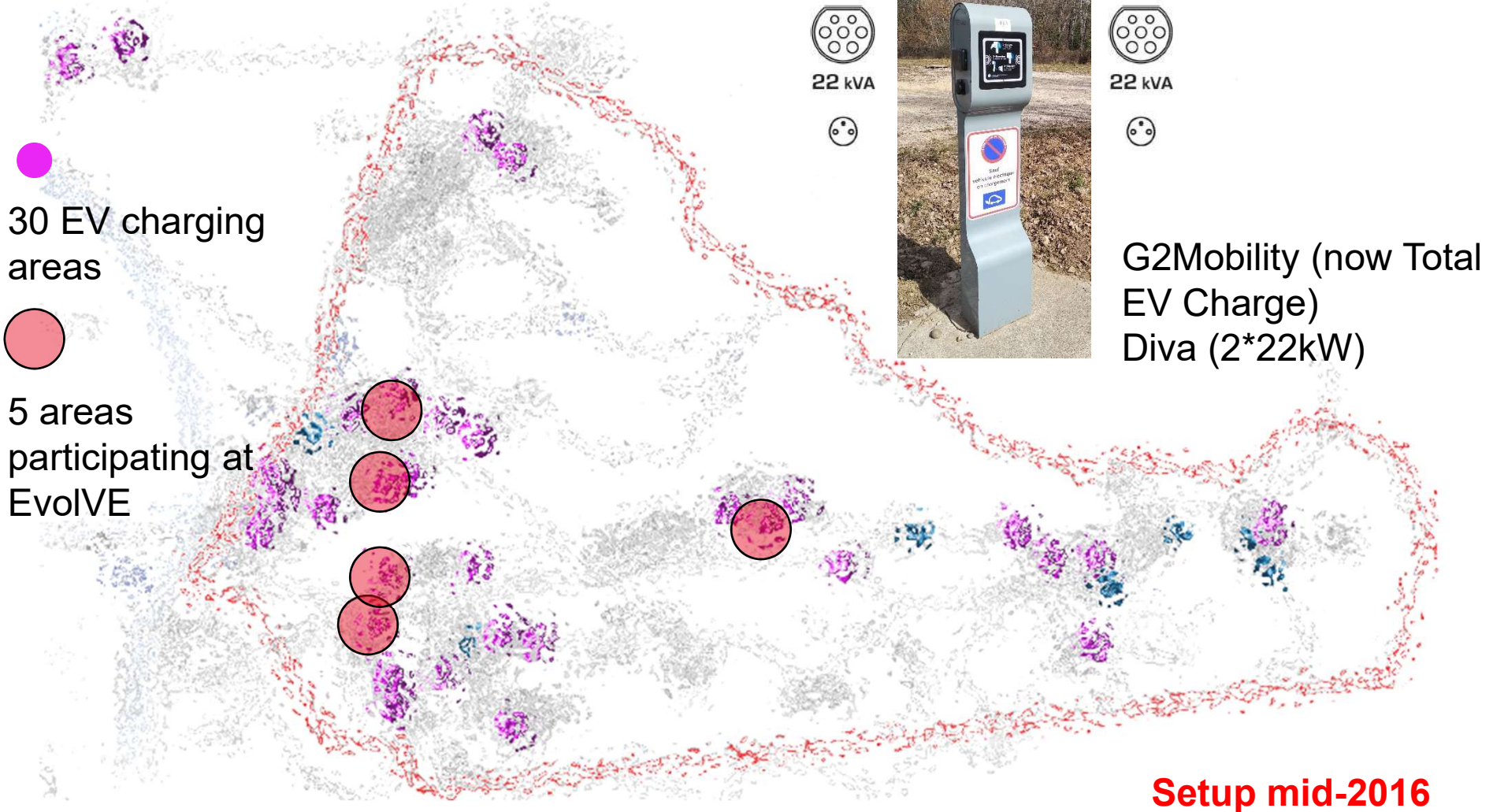

Modele	Nombre
Zoé	126
M3	4
MS	3
Kangoo	14
Golf GTE	3
Twizy	4
Fortwo	2
Leaf	11
Berlingo	4
Autre	14
e208	2
Ion	1
Partner	1
Ioniq	2
C-Zéro	1
330e	1
E-Niro	1
Outlander	2
Think city	1

67 service vehicles
51 personal vehicles
3 taxis
5 external companies vehicles

Type	#
External companies	17
Personal	85
Service	90
Taxi	3
TOTAL= 195	

Figures at march 2020
Increase ~50 EV /year

	Mode 1 et 2	Mode 3
Diva	Up to 3,7kW (AC)	Up to 22kW (AC)

Model	Battery capacity (kWh)	Max AC charging power (kW)
Zoé	{22;41;52}	22 or 43 (Mode 3) or 2.3 (Mode 2)
Leaf	{24;30;40;60}	6.7 or 3.3 or 2.3
Tesla M3	{52;77}	11 or 2.3
Tesla MS	{40;60;70;75;85;90;100}	22 or 16.5 or 11 or 2.3
Smart	17.6	22 or 2.3
Golf GTE	35.8	3.6 or 2.3
Twizy	{6;8}	3.3 or 2.3 (mode 1)
Berlingo	22.5	6.7 or 3.3 or 2.3
Kangoo	{22;33}	7 or 3.7 or 3.2 (mono)

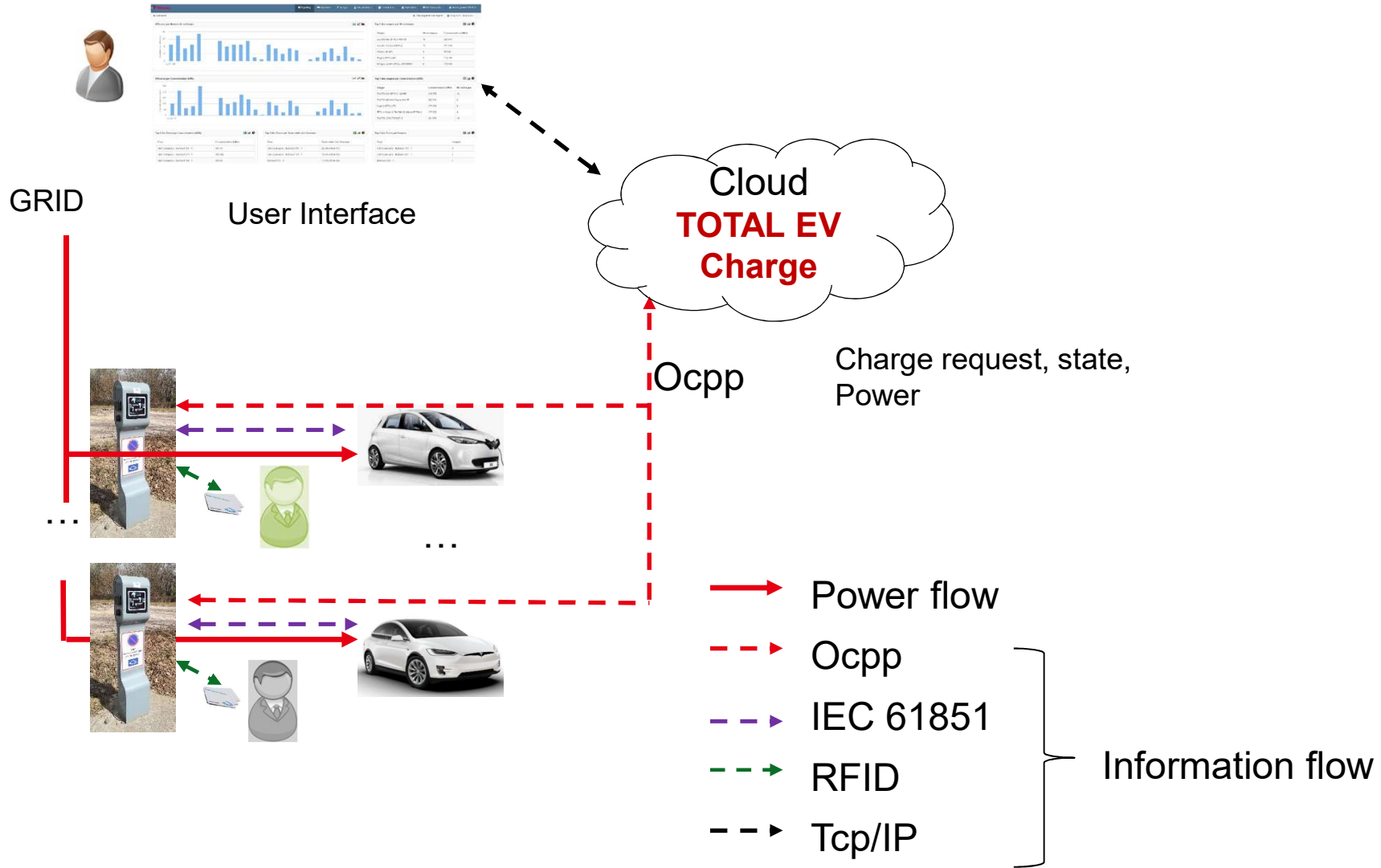

EVCI CADARACHE - DATA COLLECTION



Raw data can be downloaded from the user interface

Log of charging sessions (.xls) :

Mois	Jour	Transaction ZoneId	Nom de la PdC	Badge	Début Session	Fin Session	Début Pow Fin Power	Consomm	Type de pr	Emp	
août 2018	01/08/2018	CU-BAT31	CEA-CADA Batiment	CU-BAT31 1E6C4366	01/08/2018 06:52:54	01/08/2018 13:33:45	1697218	1710825	13.607	T2	G2M
août 2018	01/08/2018	CU-BAT12	CEA-CADA Batiment	CU-BAT12 00000000	01/08/2018 07:23:00	01/08/2018 15:49:13	1649877	1655158	5.281	EF	G2M
août 2018	01/08/2018	CU-BAT21	CEA-CADA Batiment	CU-BAT21 DEF04466	01/08/2018 07:36:25	01/08/2018 16:05:38	3261776	3266772	4.996	EF	G2M
août 2018	01/08/2018	CU-BAT35	CEA-CADA Batiment	CU-BAT35 4E184466	01/08/2018 08:01:15	06/08/2018 08:16:38	1361887	1372856	11.009	EF	G2M
août 2018	01/08/2018	CU-BAT78	CEA-CADA Batiment	CU-BAT78 DE254566	01/08/2018 08:04:46	01/08/2018 13:26:03	886570	904657	18.087	T2	G2M
août 2018	01/08/2018	CU-BAT35	CEA-CADA Batiment	CU-BAT35 00000000	01/08/2018 08:09:14	01/01/1970 01:00:00	4019320	-1	-4019.32	EF	G2M
août 2018	01/08/2018	CU-BAT15	CEA-CADA Batiment	CU-BAT15 CE94366	01/08/2018 08:22:13	01/08/2018 16:04:57	5818841	5845881	27.04	T2	G2M
août 2018	01/08/2018	CU-BAT35	CEA-CADA Batiment	CU-BAT35 2E64366	01/08/2018 08:22:40	01/08/2018 12:48:43	4225127	4146367	21.24	T2	G2M
août 2018	01/08/2018	CU-BAT15	CEA-CADA Batiment	CU-BAT15 1E6C4566	01/08/2018 08:27:02	01/08/2018 08:27:03	1217299	1217299	0	T2	G2M
août 2018	01/08/2018	CU-BAT15	CEA-CADA Batiment	CU-BAT15 1E6C4566	01/08/2018 08:27:23	01/08/2018 17:39:36	1217299	1247841	30.542	T2	G2M
août 2018	01/08/2018	CU-BAT85	CEA-CADA Batiment	CU-BAT85 8E05E97E	01/08/2018 08:48:50	01/08/2018 12:36:07	876509	884835	8.326	EF	G2M
août 2018	01/08/2018	CU-BAT27	CEA-CADA Batiment	CU-BAT27 3E6C026A	01/08/2018 08:51:41	01/08/2018 18:28:49	2708165	2733006	24.841	T2	G2M
août 2018	01/08/2018	CU-BAT31	CEA-CADA Batiment	CU-BAT31 CEDE4366	01/08/2018 09:15:53	01/08/2018 15:30:36	2015542	2058889	43.347	EF	G2M
août 2018	01/08/2018	CU-BAT23	CEA-CADA Batiment	CU-BAT23 253CE63	01/08/2018 10:56:57	01/08/2018 11:54:08	685929	700308	14.379	EF	G2M
août 2018	01/08/2018	CU-BAT27	CEA-CADA Batiment	CU-BAT27 0E64366	01/08/2018 11:26:24	01/08/2018 12:09:45	1314629	1327456	12.837	T2	G2M
août 2018	01/08/2018	CU-BAT35	CEA-CADA Batiment	CU-BAT35 3E8D4566	01/08/2018 11:55:55	01/08/2018 14:27:26	5334336	5371005	36.669	EF	G2M
août 2018	01/08/2018	CU-BAT15	CEA-CADA Batiment	CU-BAT15 AE493666	01/08/2018 16:35:40	01/08/2018 16:35:40	2976024	3004133	28.109	T2	G2M
août 2018	01/08/2018	CU-BAT22	CEA-CADA Batiment	CU-BAT22 9E8E4566	01/08/2018 12:31:22	02/08/2018 10:34:36	1444657	1453020	8.363	EF	G2M
août 2018	01/08/2018	CU-BAT85	CEA-CADA Batiment	CU-BAT85 8E05E97E	01/08/2018 12:42:58	01/08/2018 16:46:45	884835	893789	8.954	EF	G2M

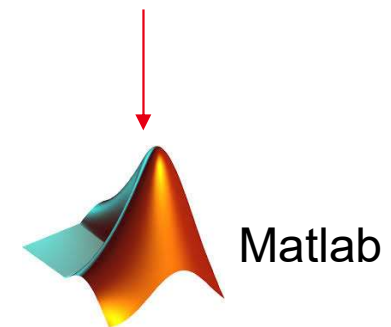

Data analysis

- **EvoIVE Project**
- **CEA EVCI & PV**
 - CEA EVCI
 - Charging modes
 - EvoIVE @INES
 - EvoIVE @Cadarache
- **Transaction analysis**
 - Transactions
 - Energy Consumption v. Transaction Duration (EC v. TD)
 - Flexibility definition & estimation
 - Beginning / end of transactions
- **Load curves**
 - Reconstruction
 - Analysis
- **Smart charging**
 - IT infrastructure
 - Autoconsumption rate
 - Examples of simulation results
 - First experimental results

LOG OF CHARGING SESSIONS



HD: Date/Time at the beginning of the session (UTC)

HF: Date/Time at the beginning of the session (UTC)

Name of the charging station

ID: Value of the powermeter at the beginning of the session (Wh)

IF: Value of the powermeter at the end of the session (Wh)

of the user

DebutSessionUTC	FinSessionUTC	PointdeCharge	Badge	IndexDebut	IndexFin	TypeDePrise
07/06/2016 11:38	07/06/2016 13:31	CU-BAT1011-13CEA-3	7490E56D	75873	80847	T2
08/06/2016 06:15	08/06/2016 11:43	CU-BAT1511-13CEA-3	CE14EB7E	74156	76878	T2
08/06/2016 11:47	08/06/2016 11:52	CU-BAT1011-13CEA-3	7490E56D	80906	81679	T2
08/06/2016 12:02	08/06/2016 13:46	CU-BAT1011-13CEA-3	7490E56D	81679	91062	T2
08/06/2016 12:22	08/06/2016 17:17	CU-BAT1011-13CEA-2	D527CEE3	29009	35782	T2
08/06/2016 12:34	08/06/2016 15:23	CU-BAT1511-13CEA-3	85F1D2E3	76878	81364	T2
08/06/2016 12:42	08/06/2016 12:57	CU-BAT8371-13CEA-2	6468EB6D	2686	3142	T2
08/06/2016 12:59	09/06/2016 08:38	CU-BAT8371-13CEA-2	6468EB6D	3145	66192	T2
08/06/2016 13:04	08/06/2016 13:08	CU-BAT8371-13CEA-6	6503DCE3	765	1566	T2

Transaction Duration (h)=(HD – HF)

Energy Consumption (kWh)=(IF – ID)/1000

Unreliable

Period 01/06/2016 to 31/05/2020 :

- 17045 transactions
- Sum of consumptions : 253.2 MWh
- ~1500000km @17kWh/100km
- 252 t de CO₂ avoided

Year of purchase: 2020

Vehicle Segment: Medium car (ex: Volkswagen Golf)

VS

Technology: Electric vs Diesel

Electricity used for battery production: China vs EU average

Country where the electric car is driven: France vs Sweden

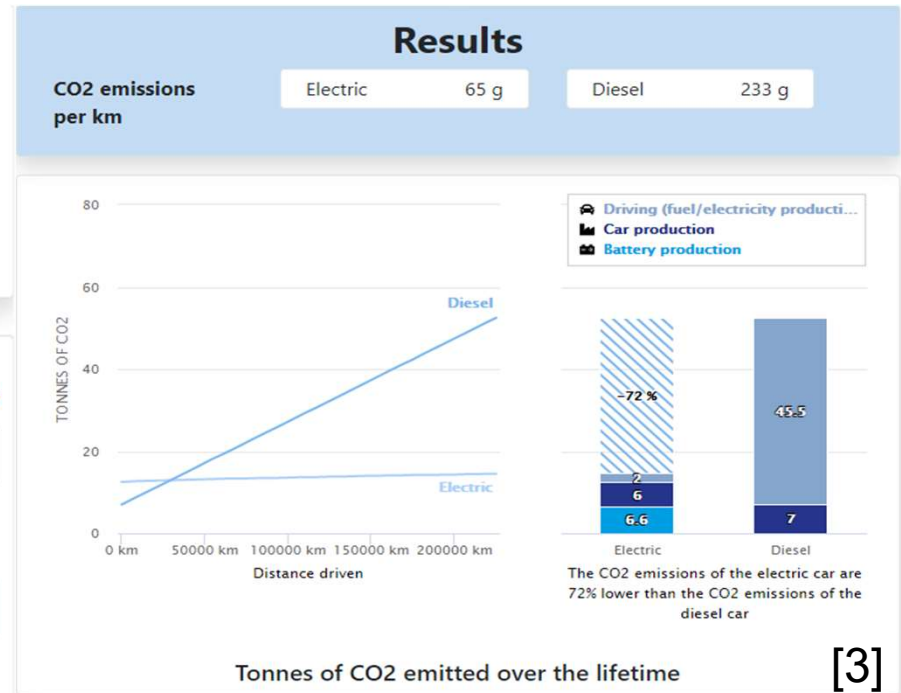

For more details on the assumptions and the methodology, please see [T&E's explanatory note](#)

STATISTICS ON TRANSACTIONS

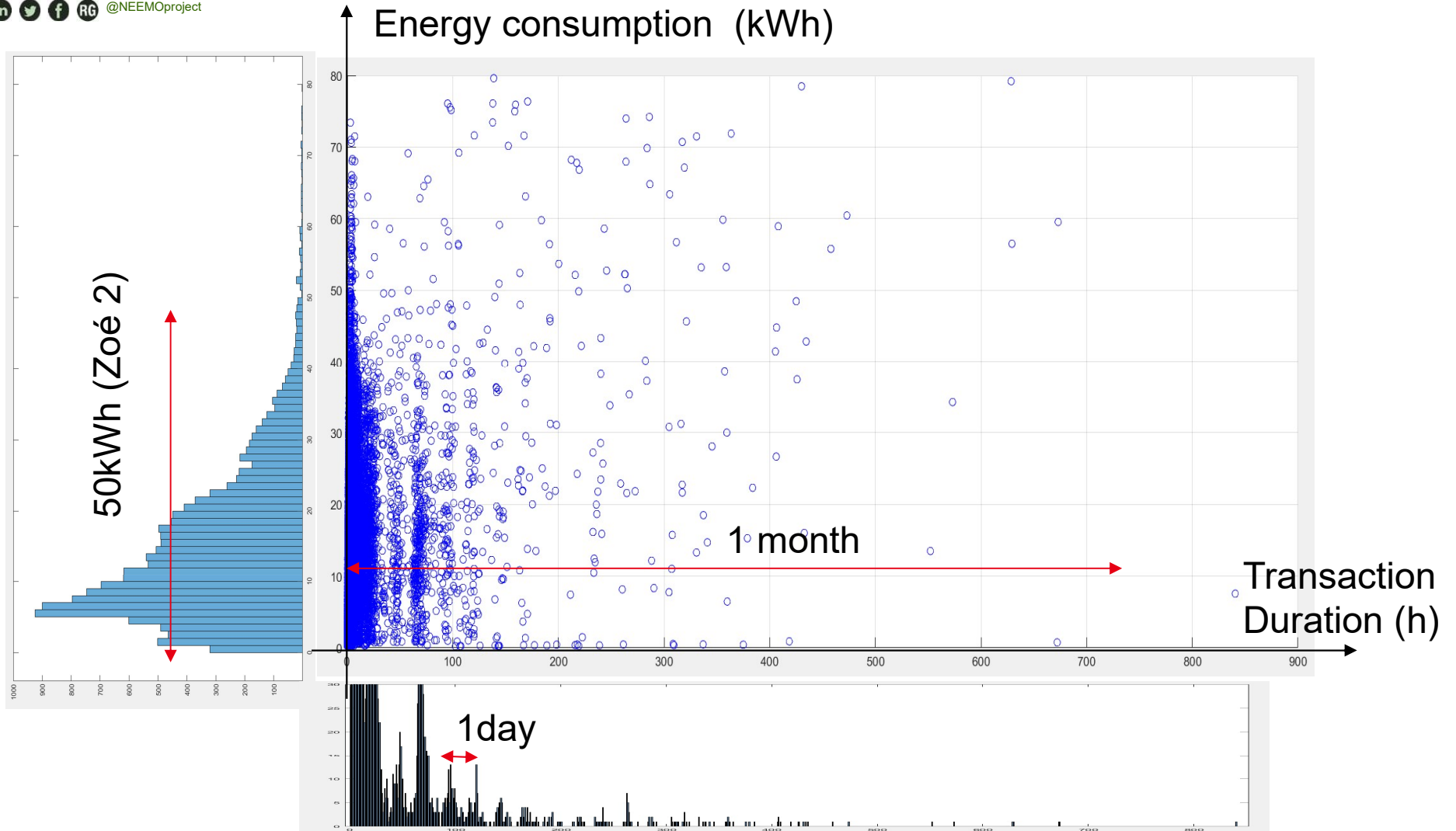

ENERGY CONSUMPTION / TRANSACTION

Mean of the energy consumption per transaction : 14.8 kWh

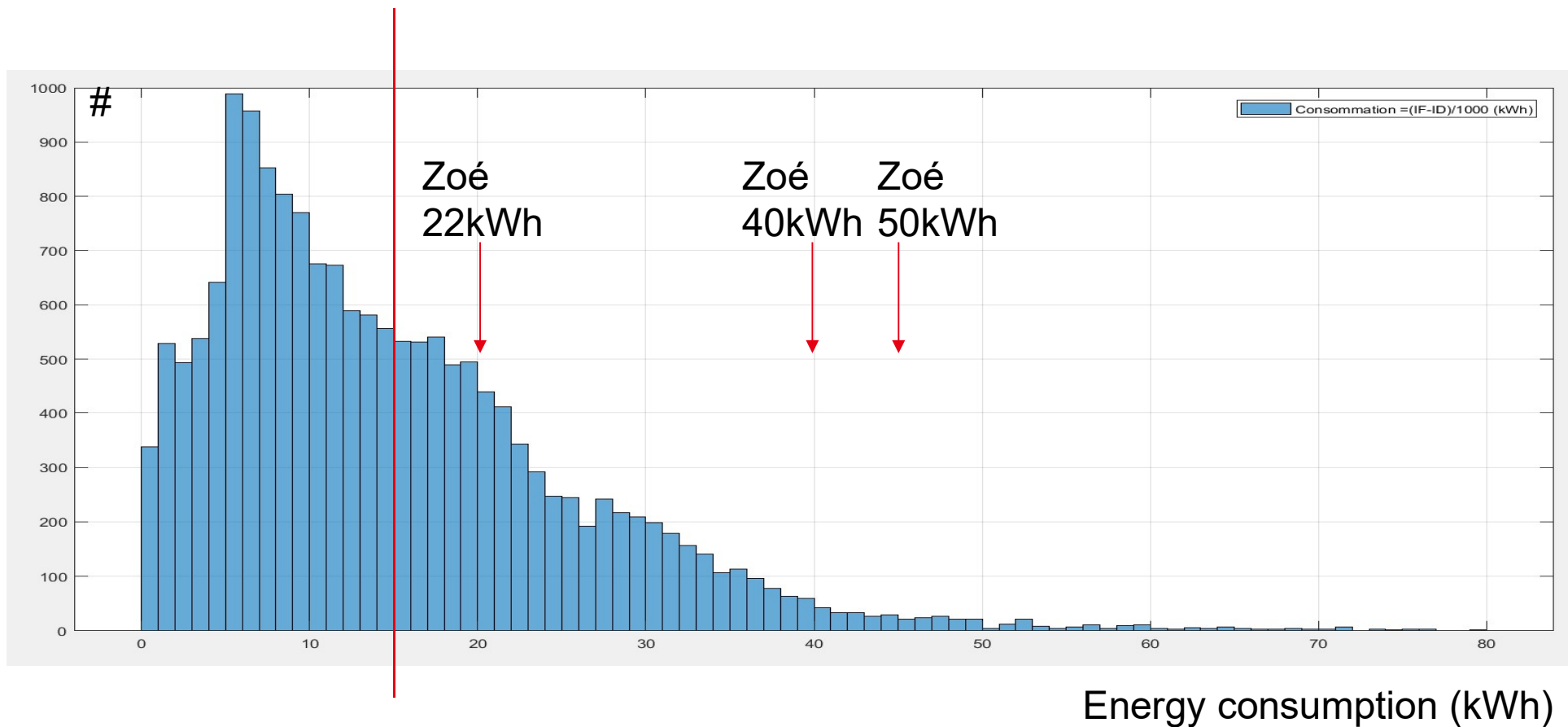

STATISTICS ON TRANSACTIONS



Full workday charging i.e
 -start after 7h and finish before 17h the same day
 -and charge duration greater than 7h
 (743 occurrences (4.7%))

Full night charging i.e
 -start after 15h and finish before 9h the
 following day
 (430 occurrences (2.7%))

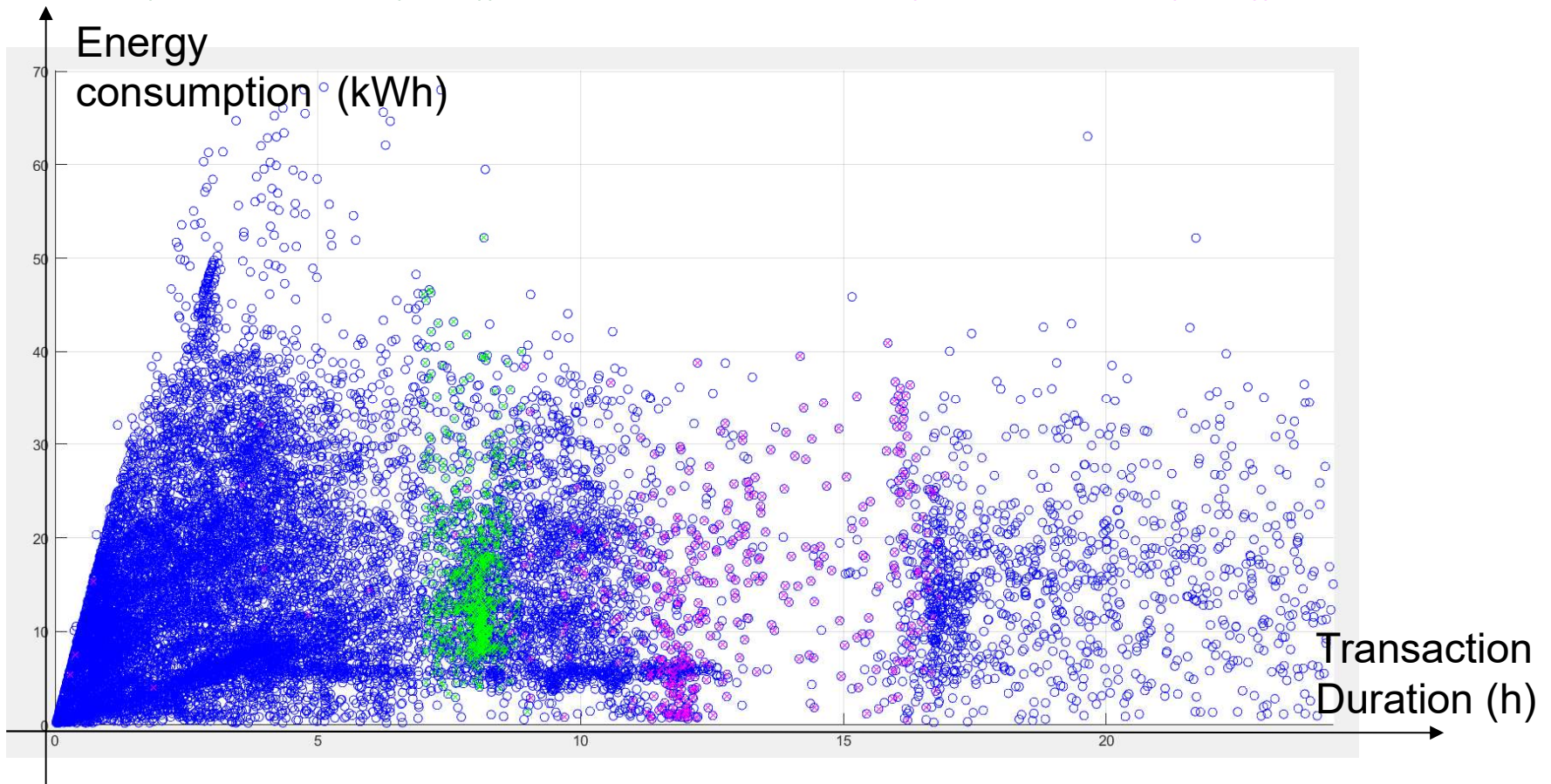

DURATION OF TRANSACTION

Mean of the transaction duration : 12.4h

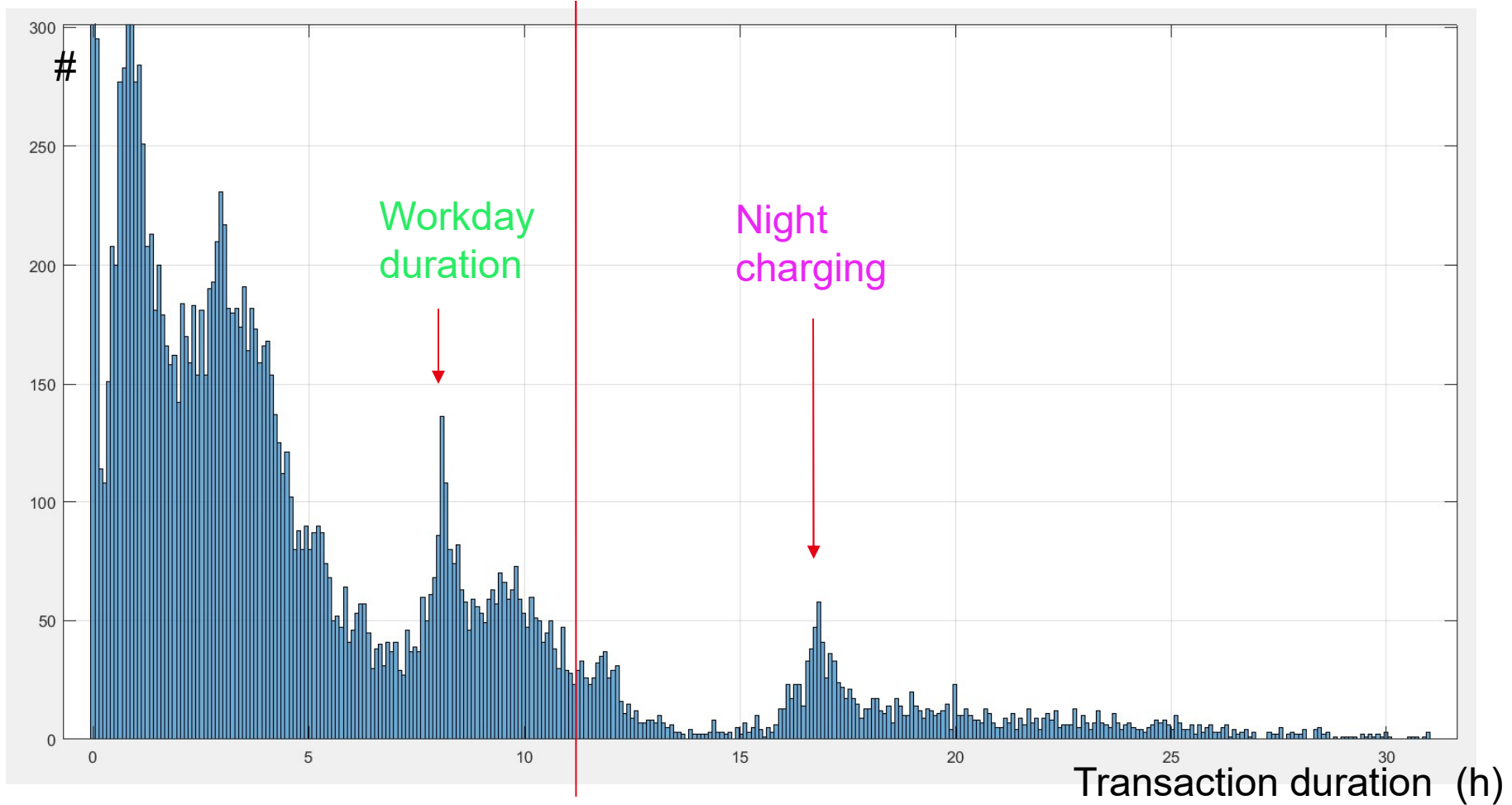

STATISTICS ON TRANSACTIONS

Energy
consumption (kWh)

$$EC = \text{Power (kW)} * TD$$

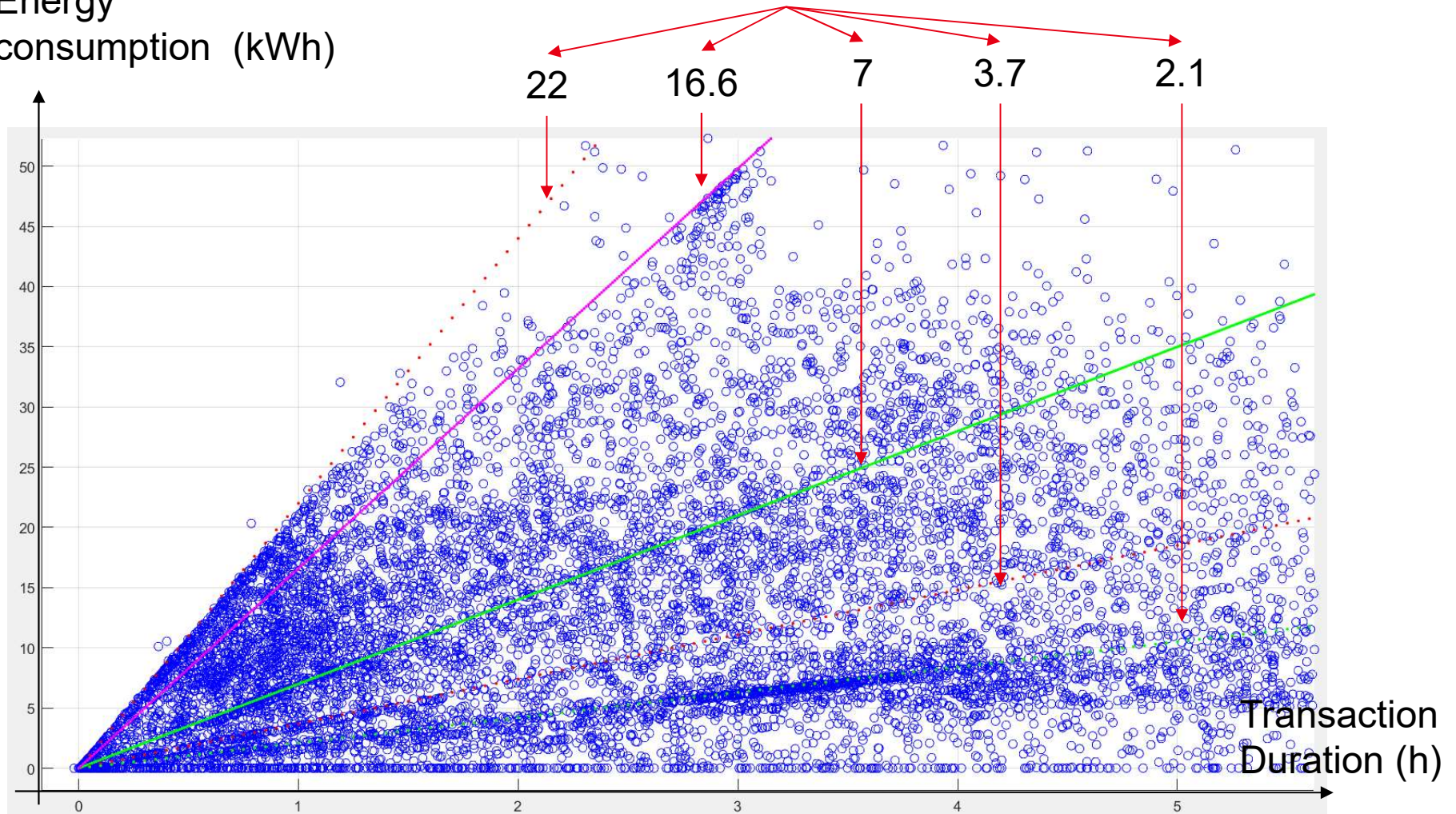

STATISTICS ON TRANSACTIONS

Energy consumption (kWh)

$$EC = \text{Power (kW)} * TD$$

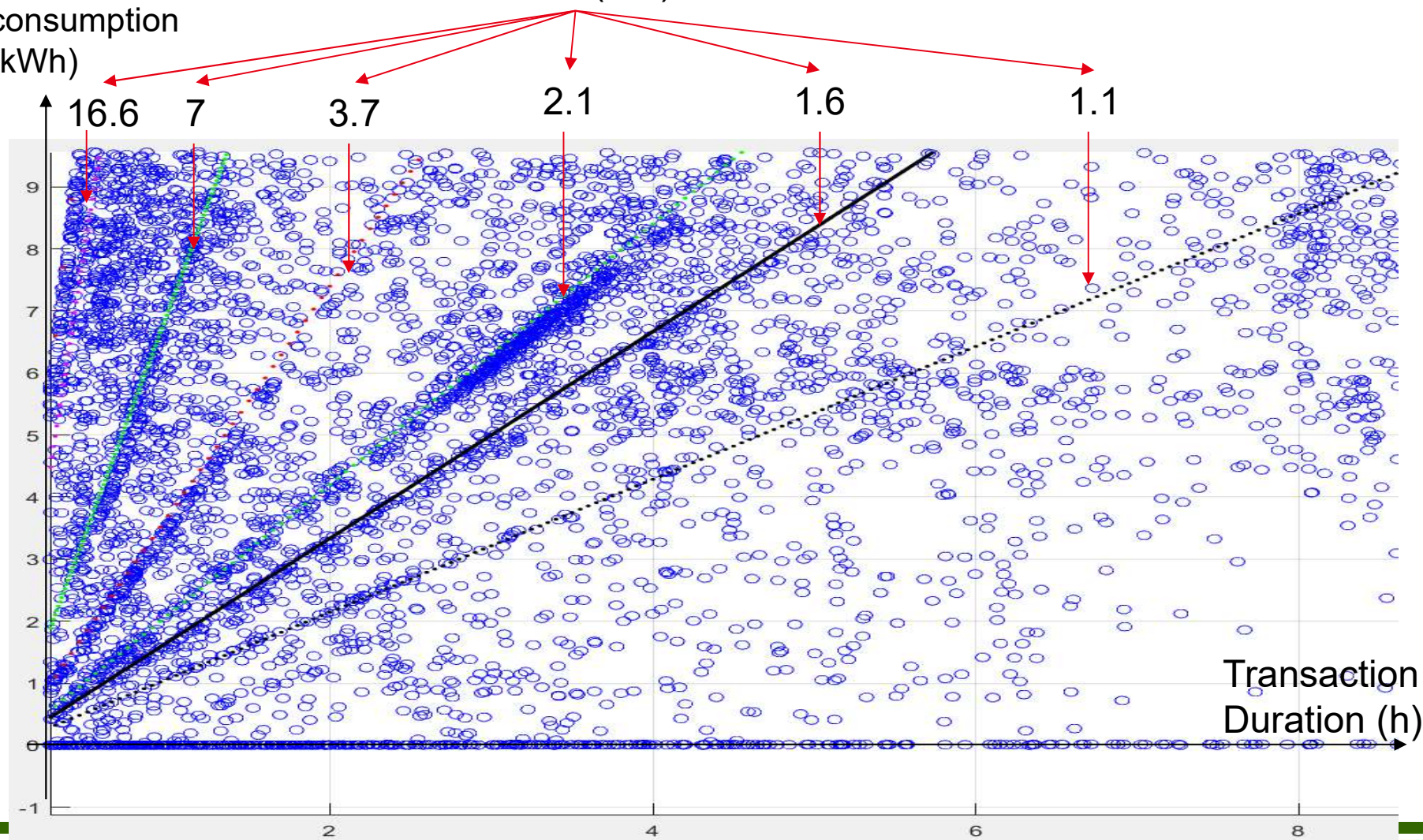

DEFINITIONS : PARAMETERS OF CHARGE

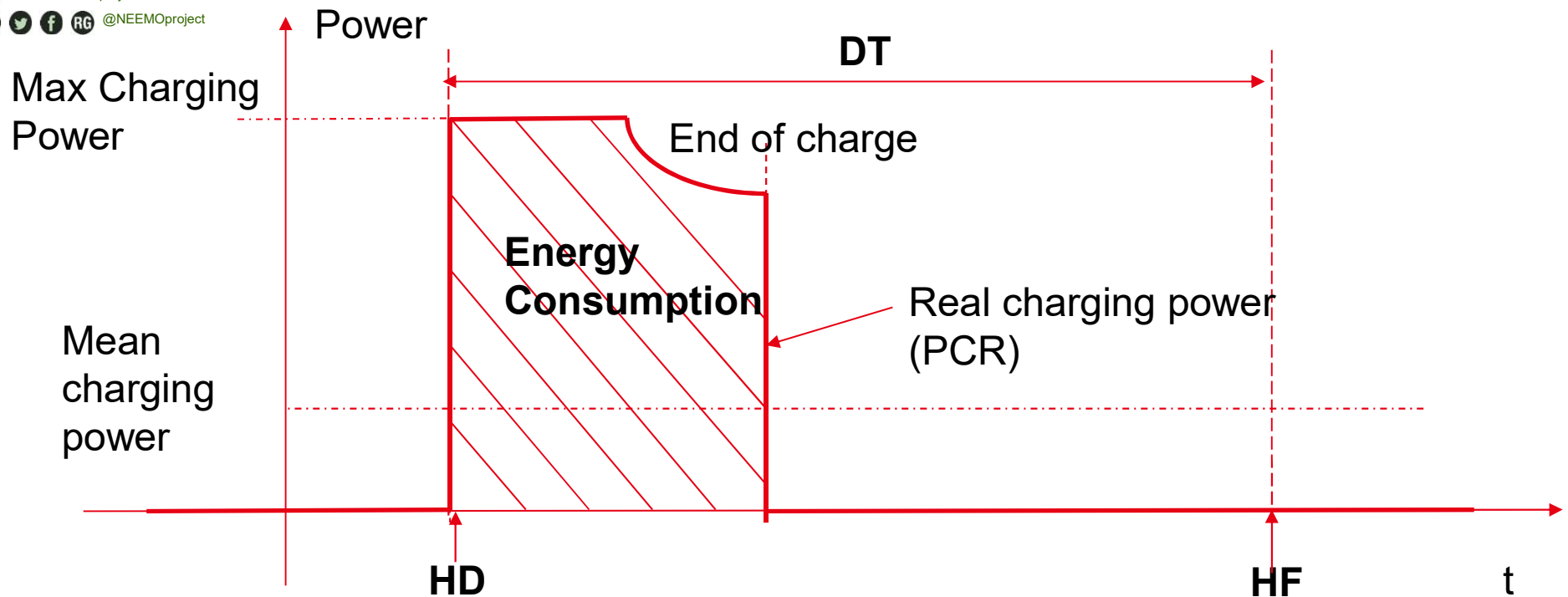

Real Charging Power = PCR => not recorded ; could be estimated

Transaction duration= $DT=HF-HD$ => recorded in the transaction file

Energy Consumption = $EC = ID - IF$ => recorded in the transaction file

Battery capacity = Max of energy consumption = EC_{Max} => depends of the EV model

Max Charging Power = PCM => depends of the EV model

Mean charging power = $PCMean = EC/DT$ => can be calculated

DEFINITION : FLEXIBILITY

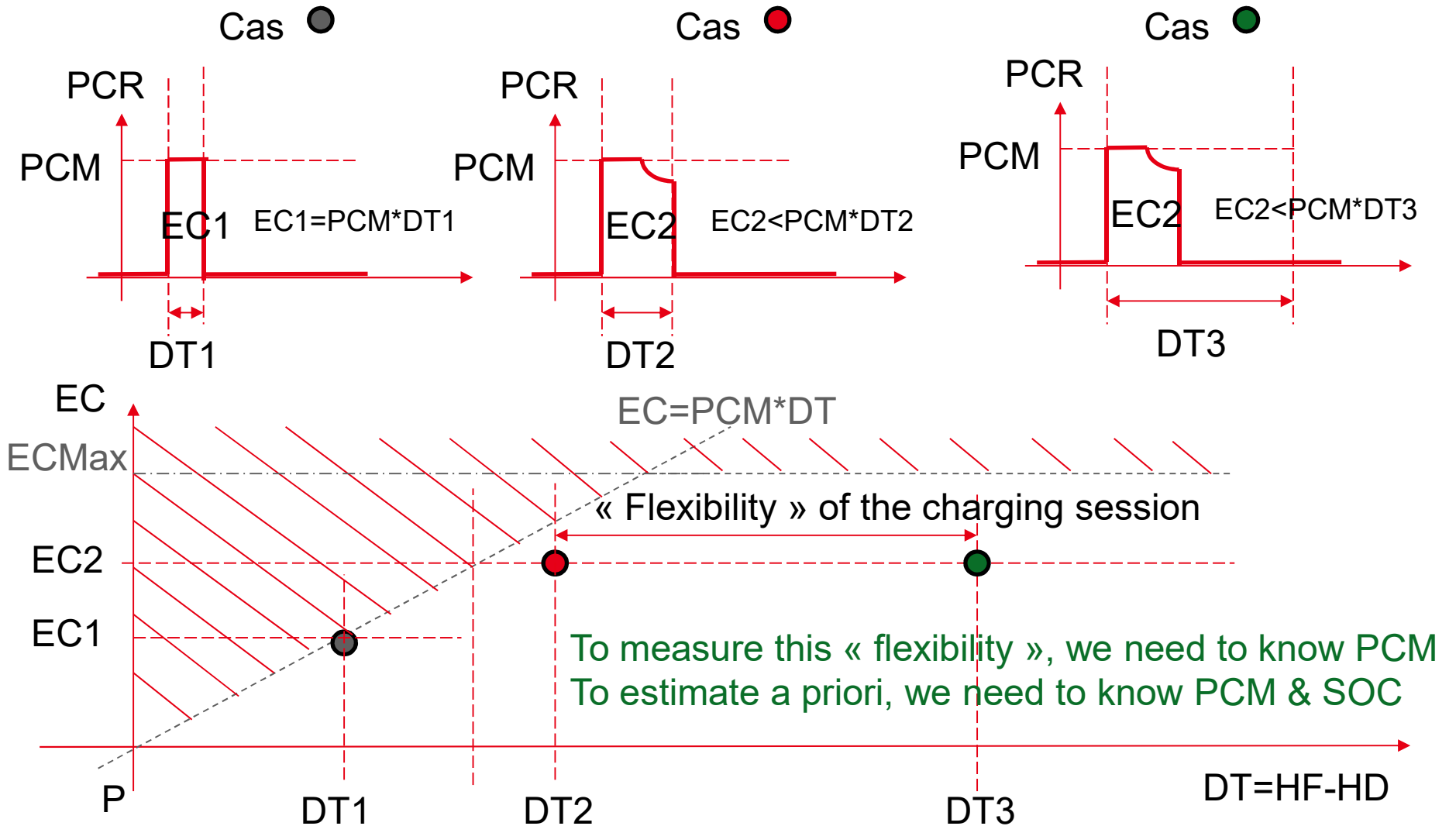

EXAMPLE : ALL THE ZOE

Zoe charging @ 22kW (mode 3)

EC (kWh)

ECMax

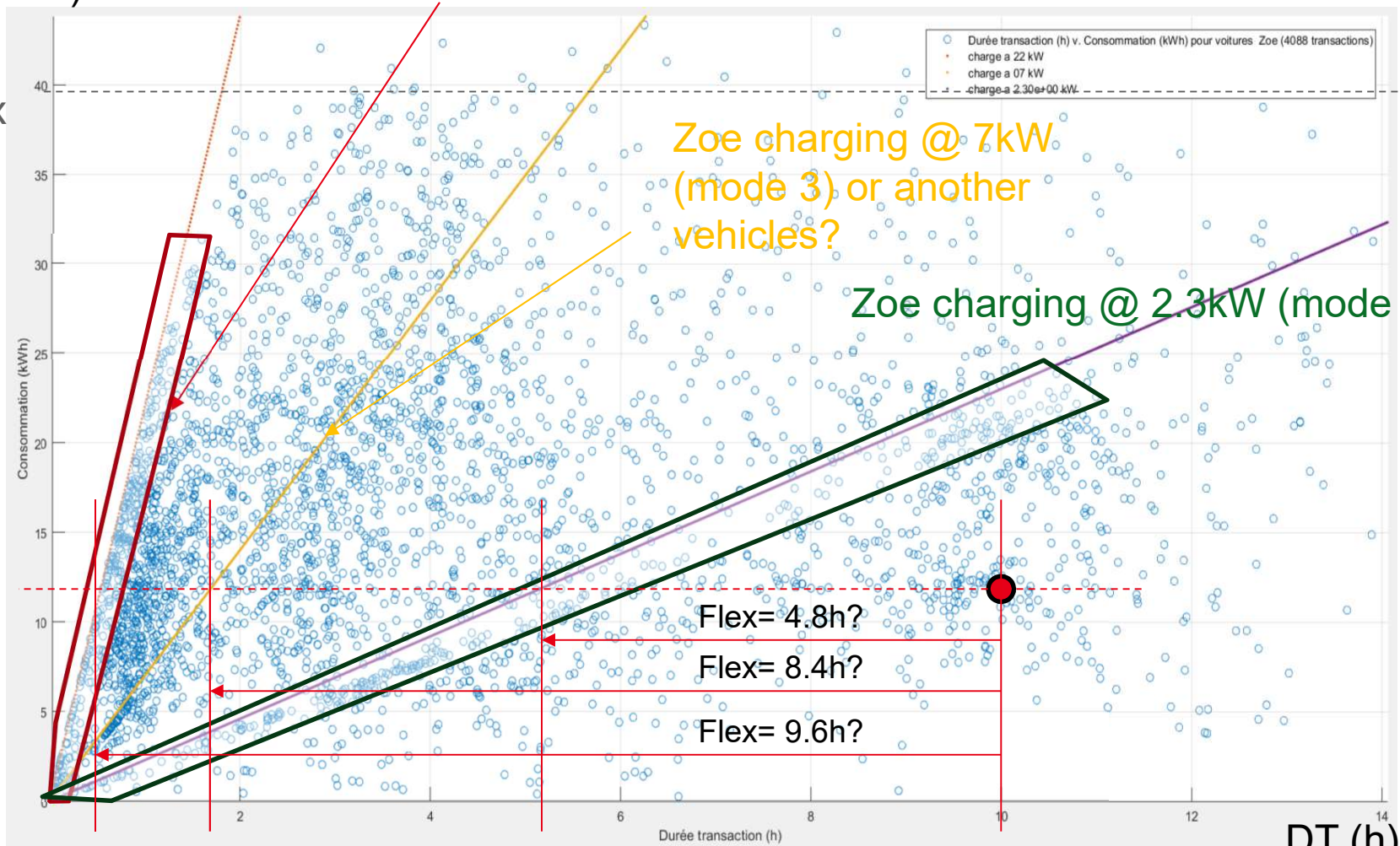

EXAMPLE : ALL THE TESLA

EC (kWh)

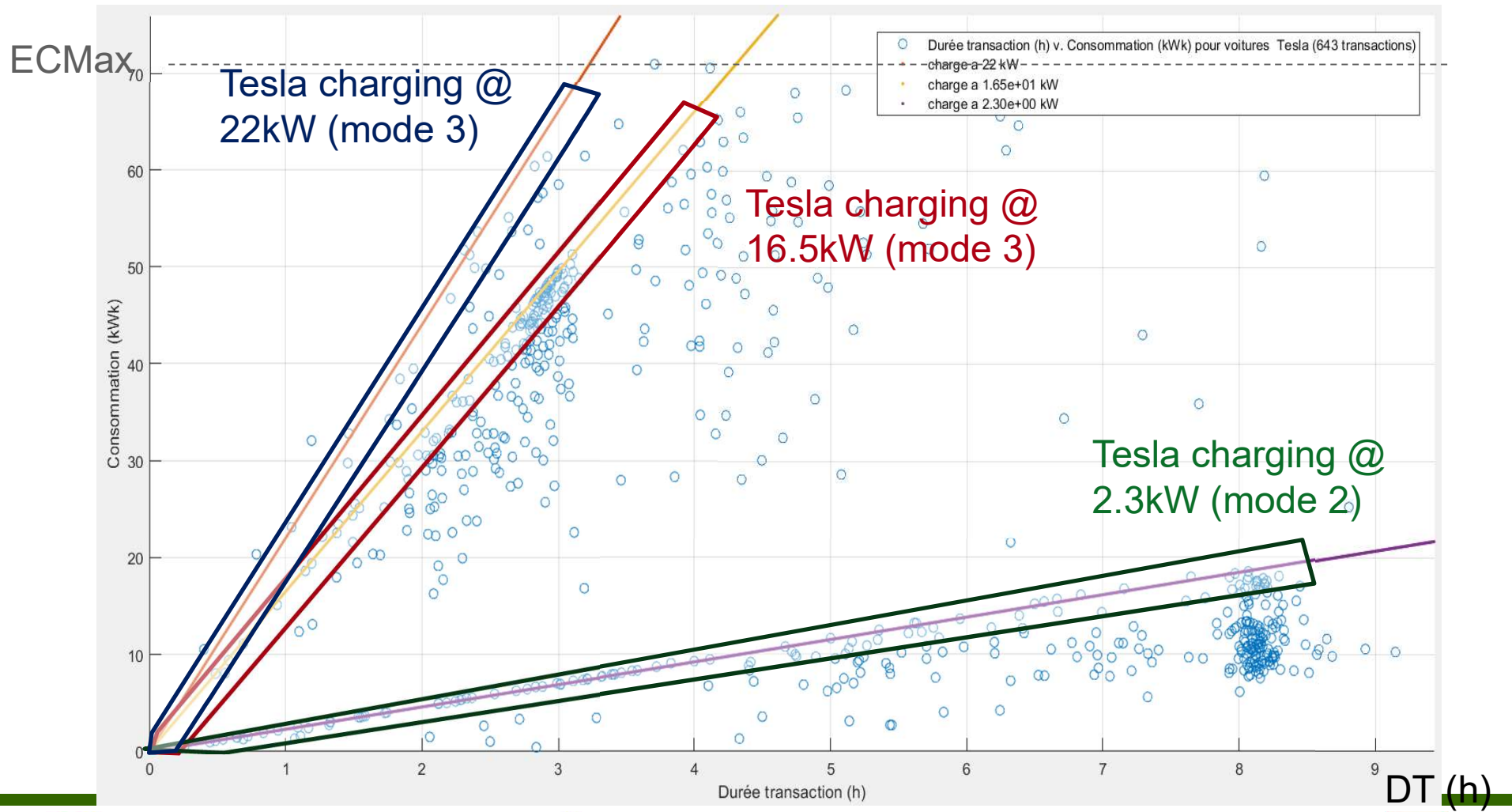

EXAMPLE: ALL THE LEAF

EC (kWh)

ECMax

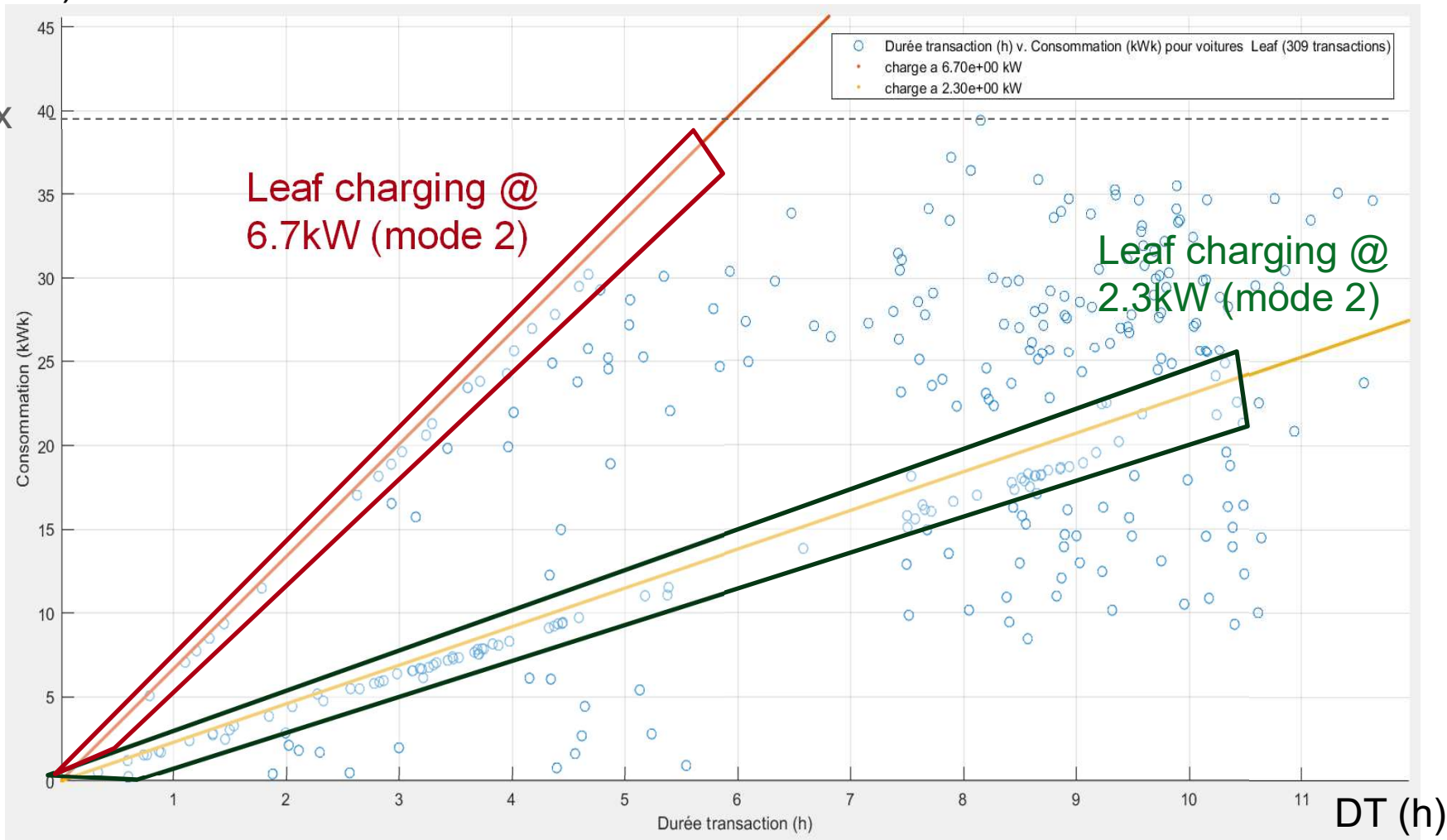

EXAMPLE: ONE GOLF GTE (PHEV)

Estimation of PCM = 1.1 kW (mode 3 with T2 connector)

EC/PCM (kWh)

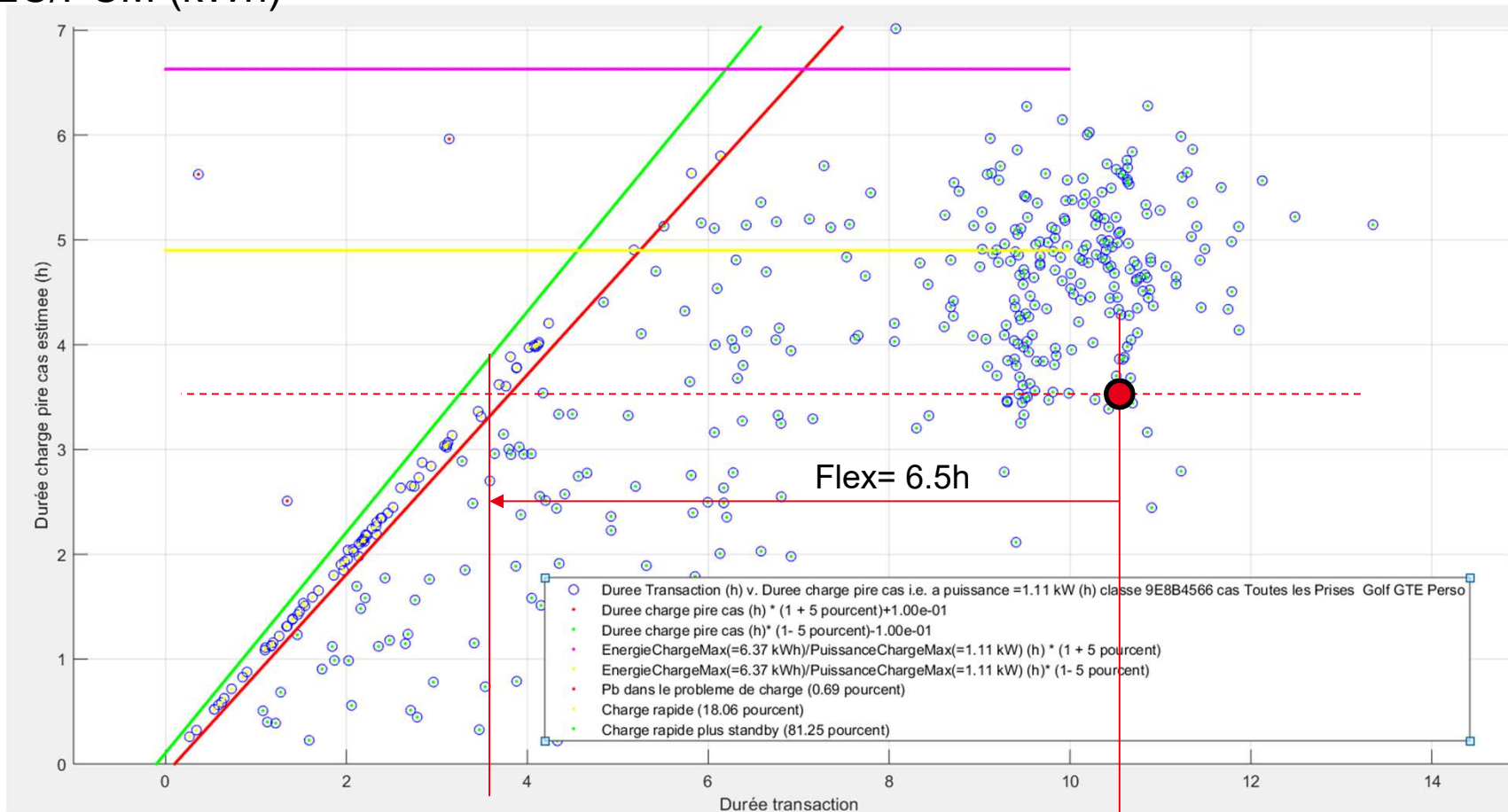

TD (h)

START/END OF TRANSACTIONS

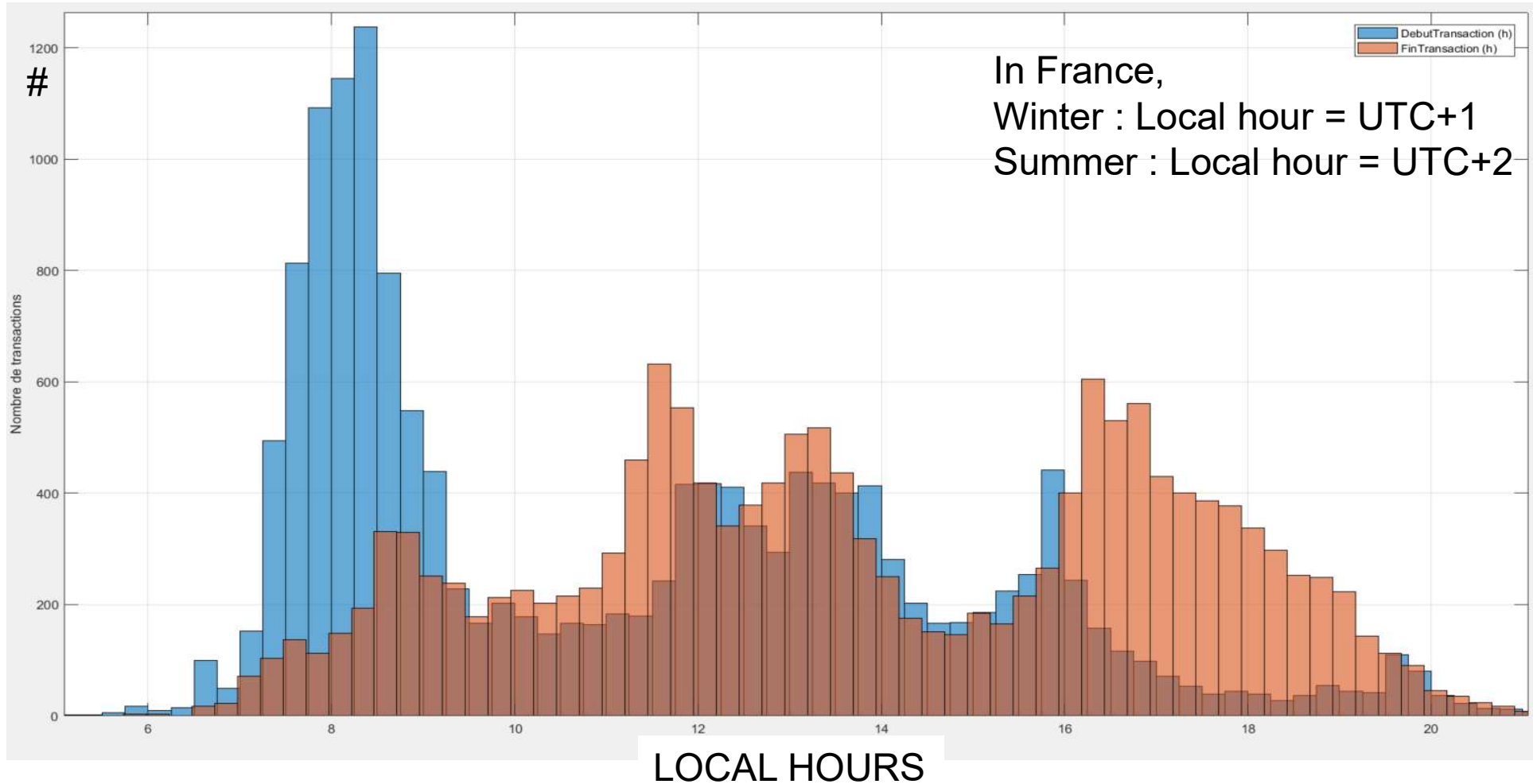

START/END OF TRANSACTIONS : 'TAXI'

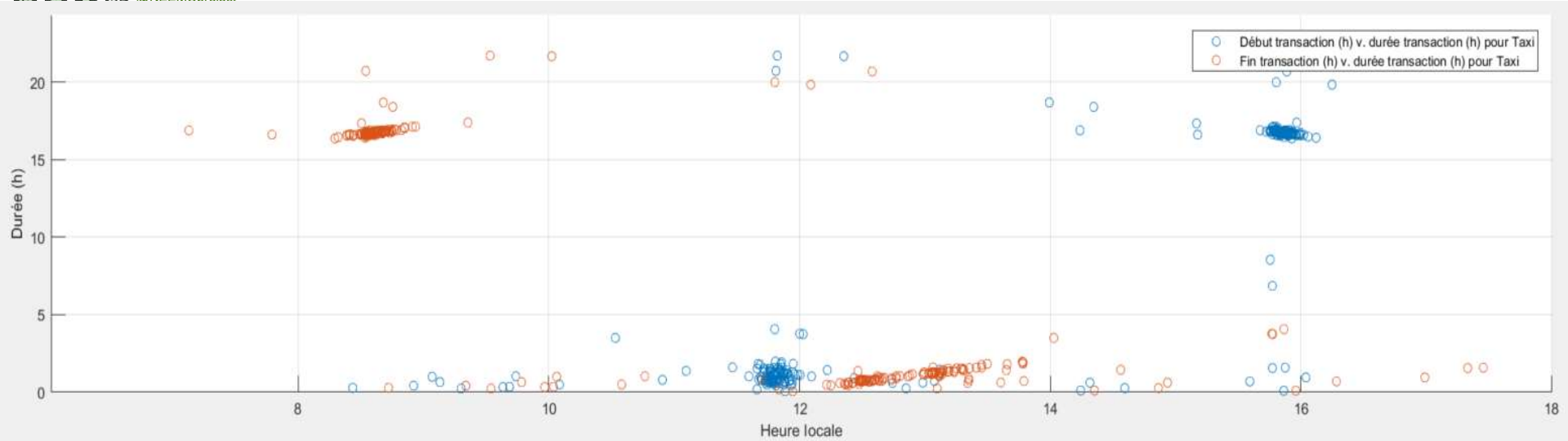

« night » charge

« midday » charge

« night » charge

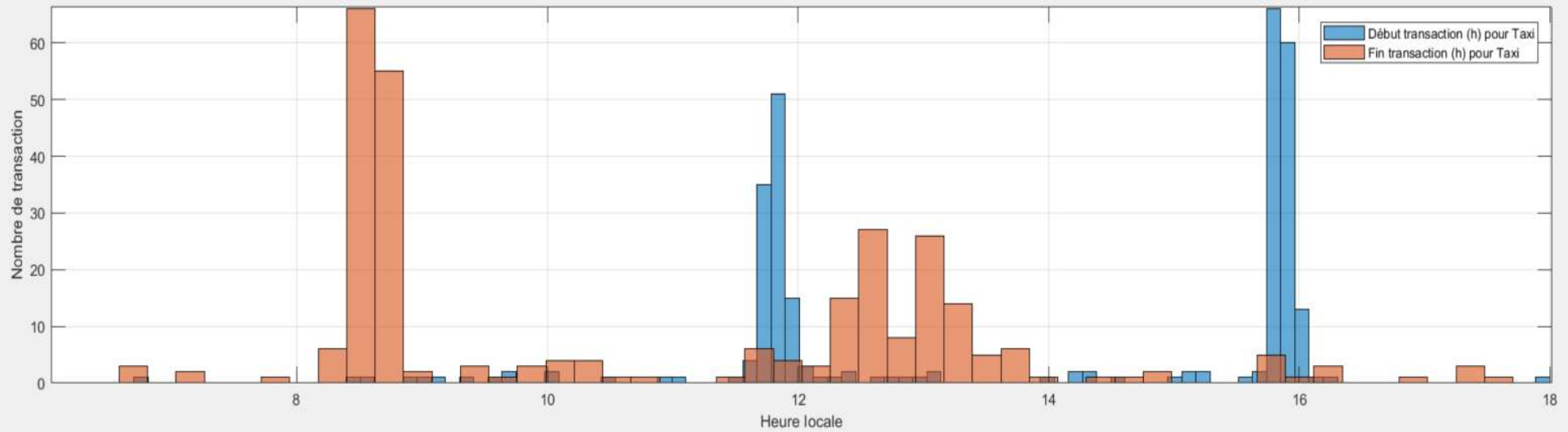

START/END OF TRANSACTIONS : SERVICE VEHICLE

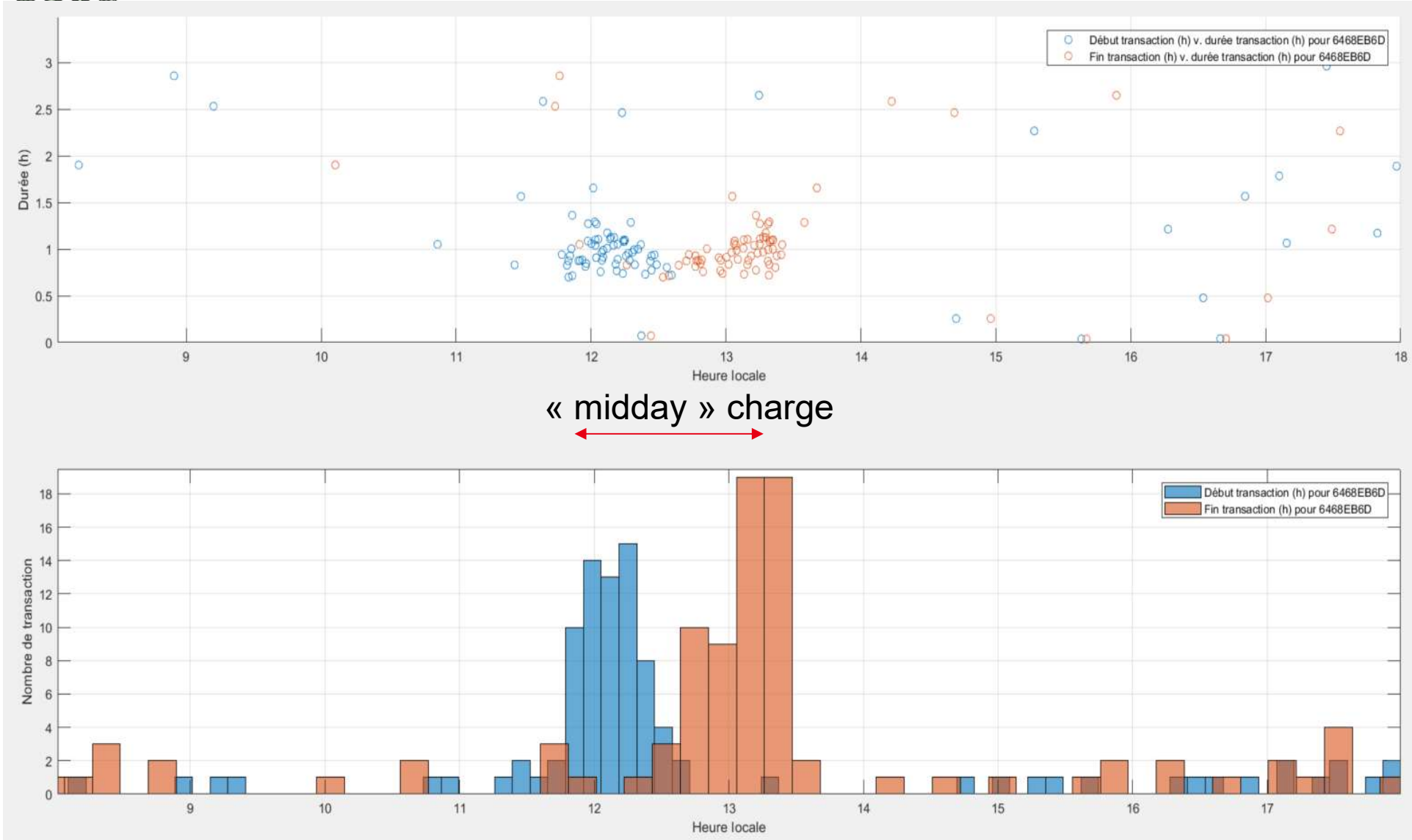

START/END OF TRANSACTIONS : PERSONAL VEHICLE

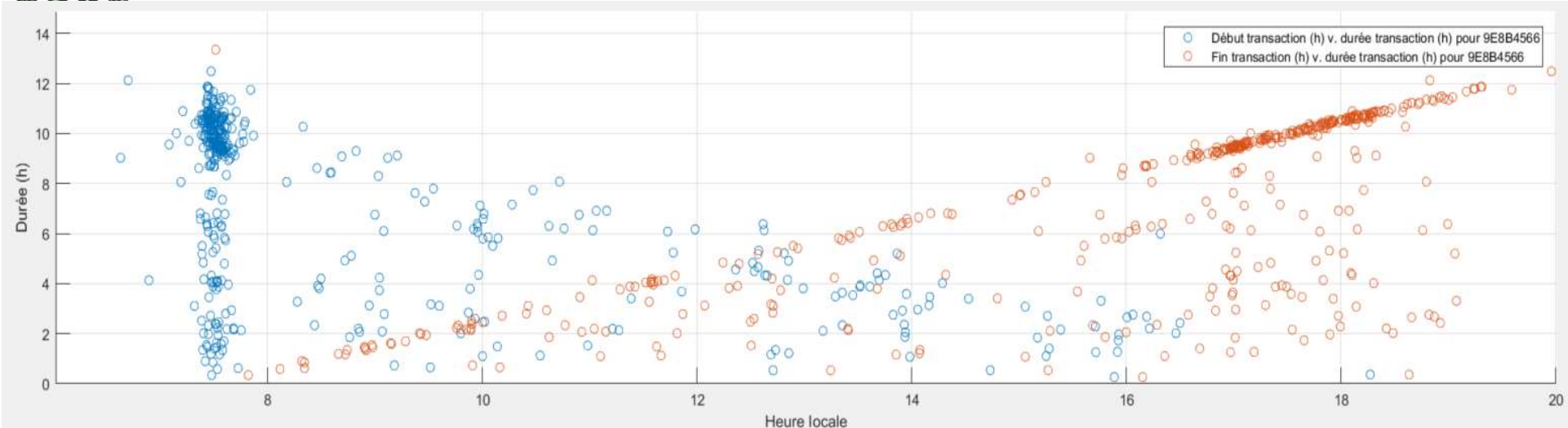

Full workday charge

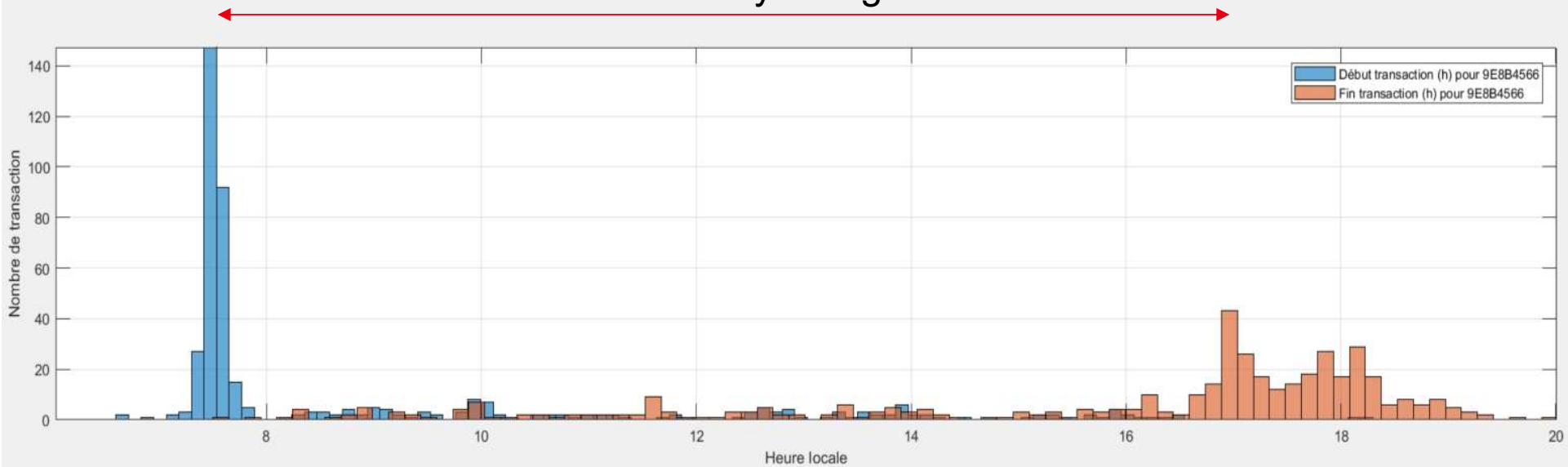

- **EvoIVE Project**
- **CEA EVCI & PV**
 - CEA EVCI
 - Charging modes
 - EvoIVE @INES
 - EvoIVE @Cadarache
- **Transaction analysis**
 - Transactions
 - Energy Consumption v. Transaction Duration (EC v. TD)
 - Flexibility definition & estimation
 - Beginning / end of transactions
- **Load curves**
 - Reconstruction
 - Analysis
- **Smart charging**
 - IT infrastructure
 - Autoconsumption rate
 - Examples of simulation results
 - First experimental results

MEAN CHARGING POWER HYP. : PRINCIPLE OF RECONSTRUCTION

1	Mois	Jour	Uui Tran	Zonelc	Nom de la Zone	PdC	Badge	Début Session	Fin Session	Début Pow	Fin Power	Consomm	Type de pr	Emsp
2	#####	05/12/2018	b81	CU-F	CEA-C Batiment 101 - 1	CU-BAT1011-13CEA-1	7490E56D	05/12/2018 14:50:37	05/12/2018 16:03:58	1227407	1238878	11.471	T2	G2M
3	#####	06/12/2018	20b	CU-F	CEA-C Batiment 101 - 1	CU-BAT1011-13CEA-1	1E974366	06/12/2018 10:12:27	06/12/2018 13:48:08	1238909	1258302	19.393	T2	G2M
4	#####	13/12/2018	749	CU-F	CEA-C Batiment 101 - 1	CU-BAT1011-13CEA-1	4E8E4566	13/12/2018 16:13:56	13/12/2018 20:14:35	1258601	1269056	10.455	T2	G2M
5	#####	21/12/2018	6d4	CU-F	CEA-C Batiment 101 - 1	CU-BAT1011-13CEA-1	3EF7EB7E	21/12/2018 15:31:02	21/12/2018 16:41:32	1269392	1276502	7.11	T2	G2M

n-1
n

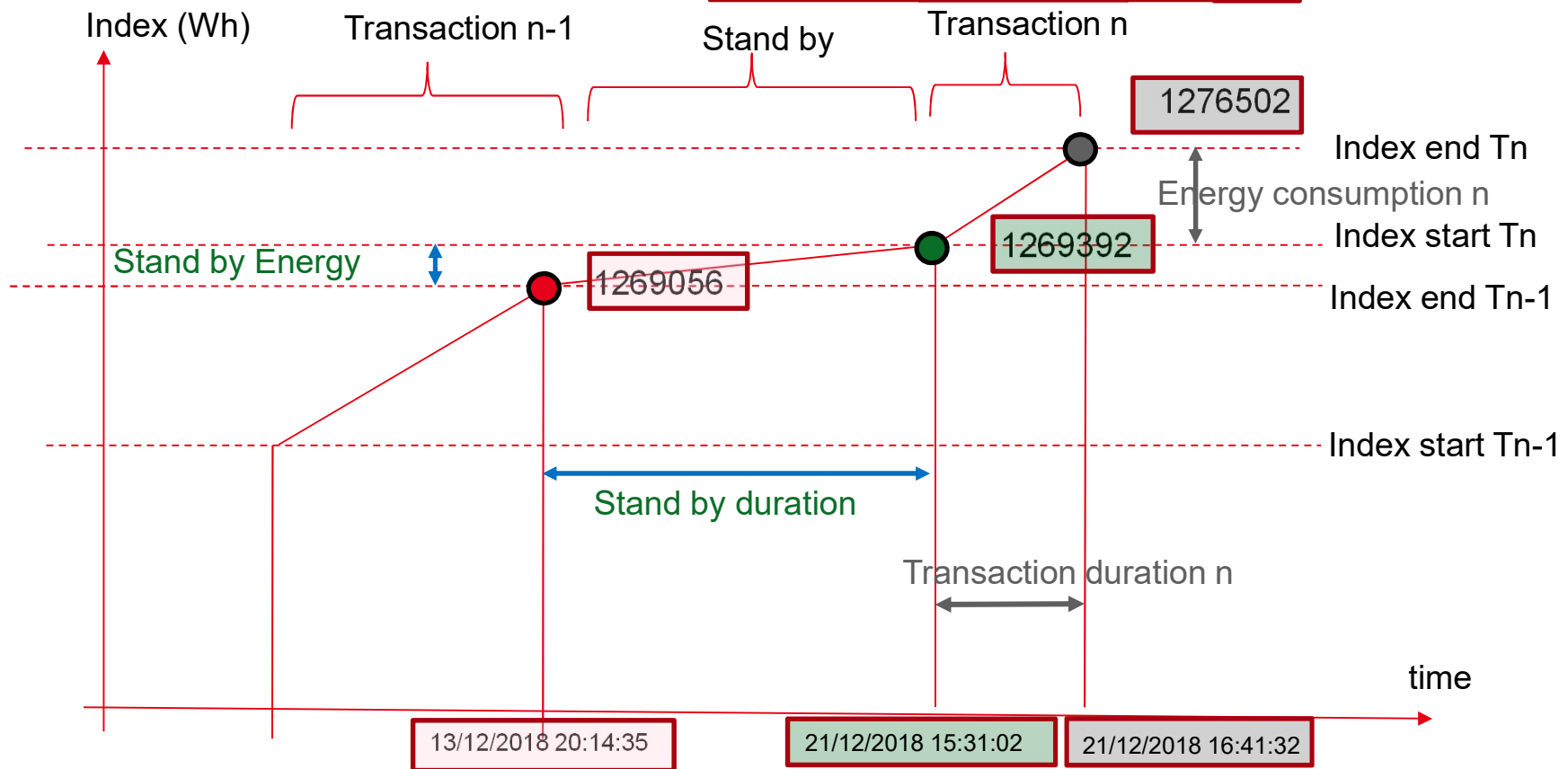

MEAN CHARGING POWER HYP. : PRINCIPLE OF RECONSTRUCTION

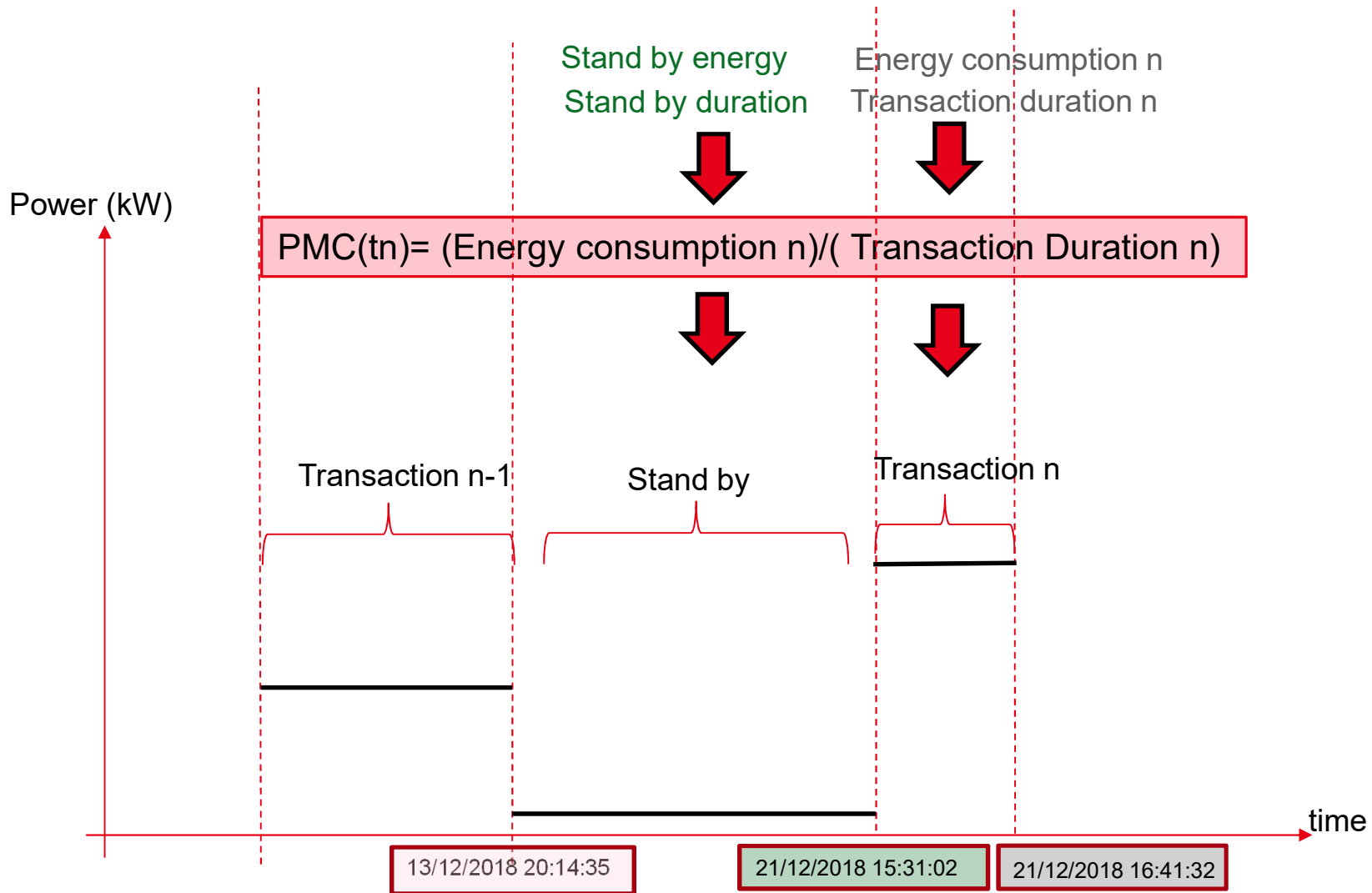

MEAN CHARGING POWER HYP. : EXAMPLES



PdC: CU_BAT1011_13CEA

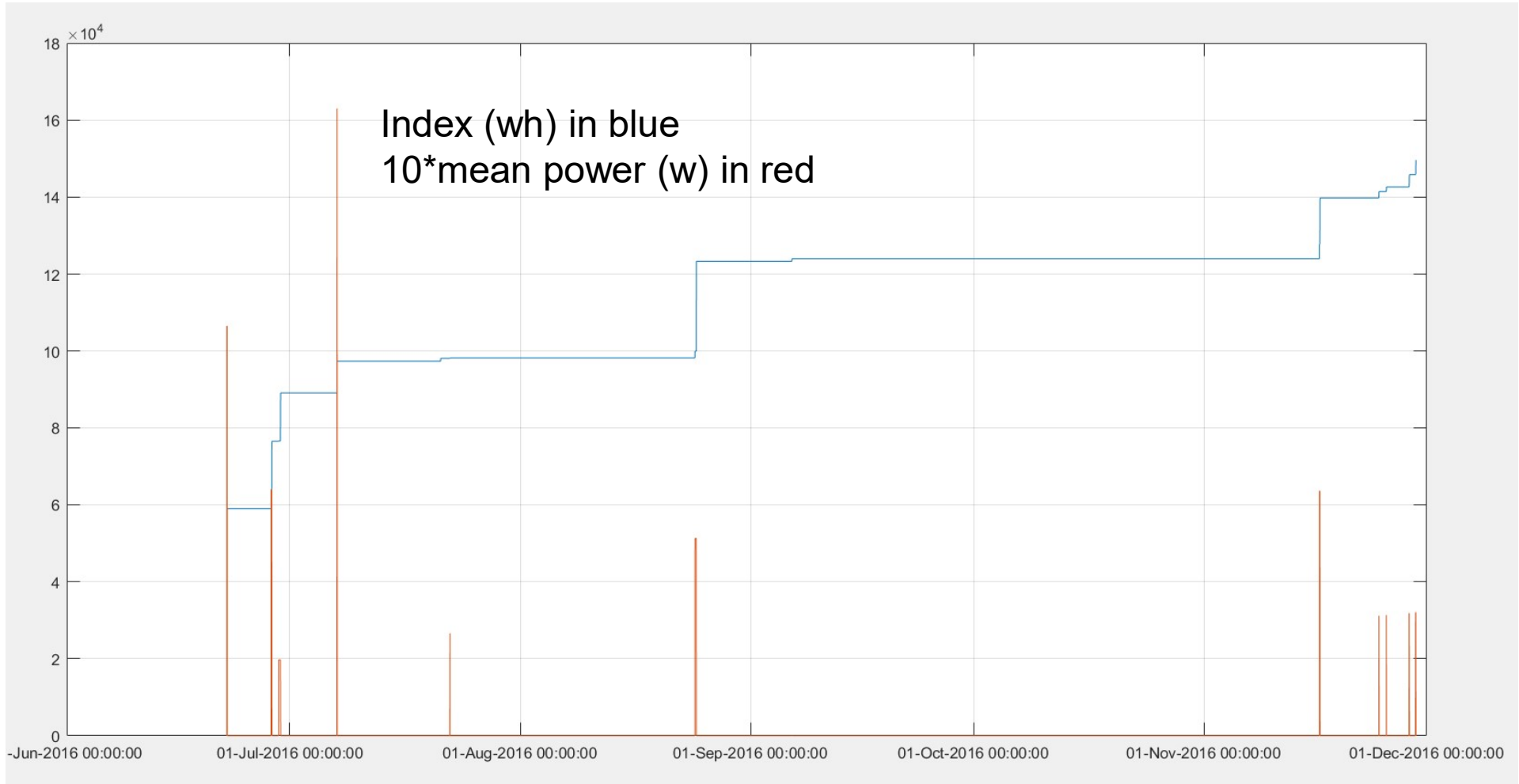

Energy indexes of the 81 charging stations (Wh)

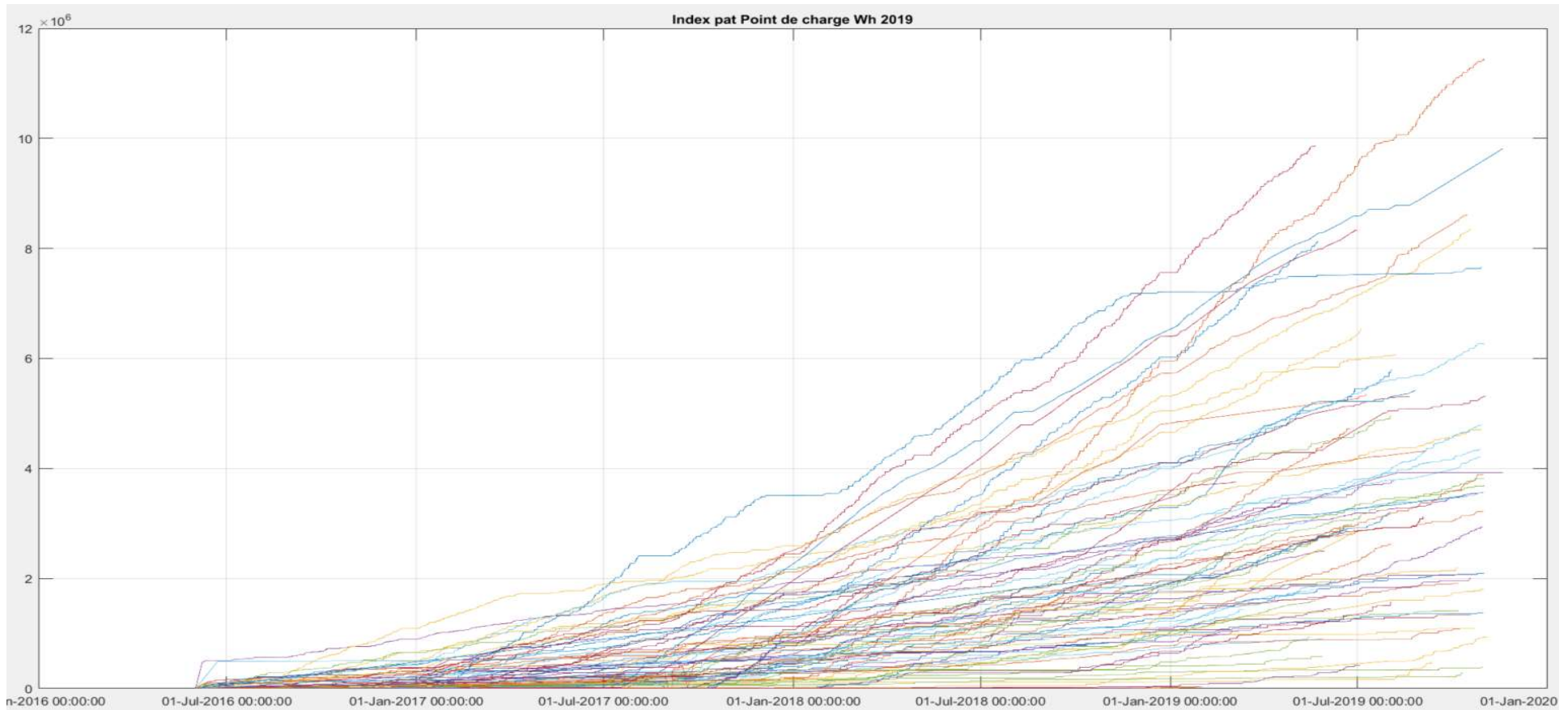

MEAN CHARGING POWER HYP. : AGGREGATED LOAD CURVE

Total of the mean power for 81 charging stations (year 2018)

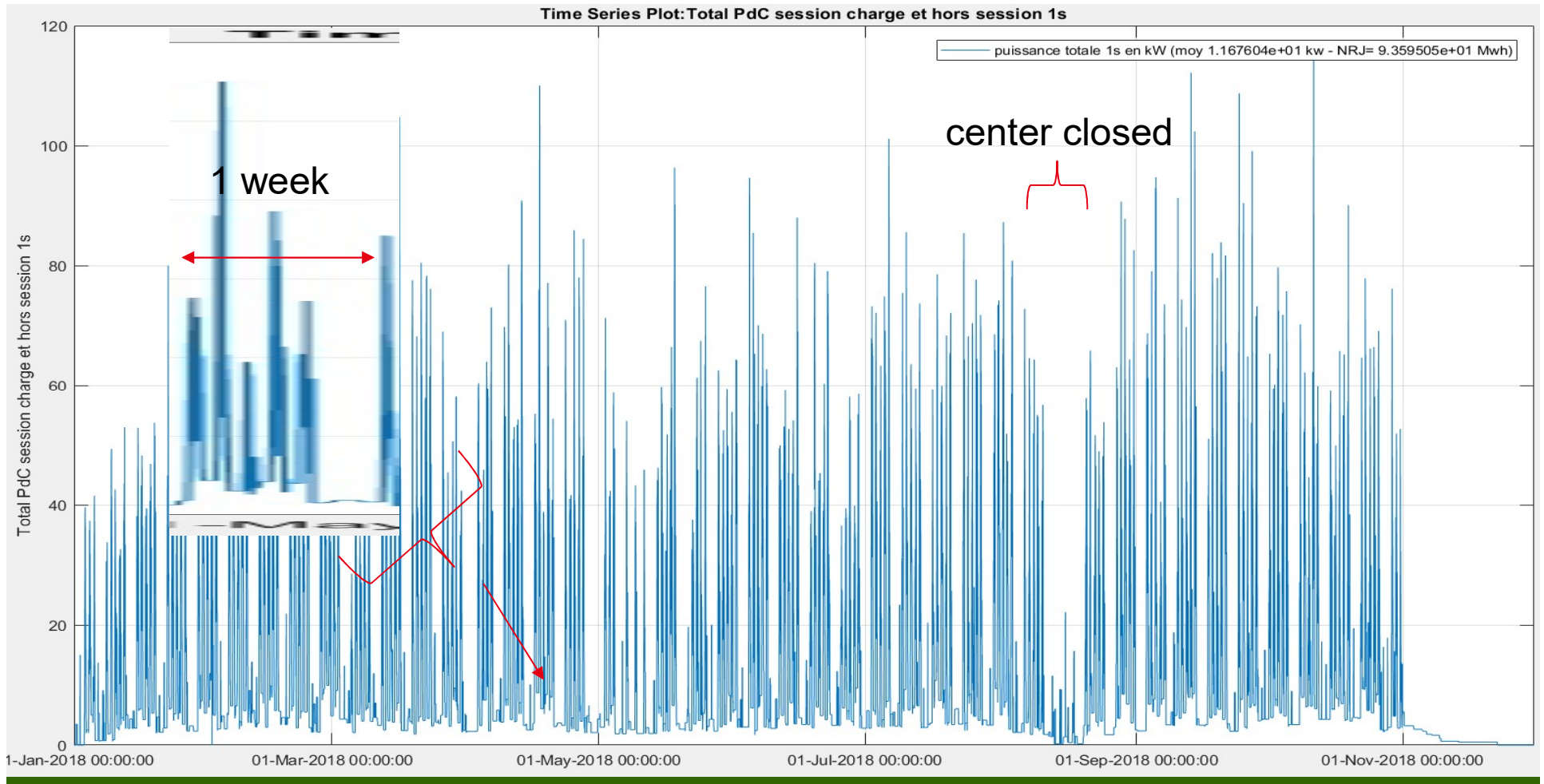

MAX CHARGING POWER HYP. : PRINCIPLES OF RECONSTRUCTION

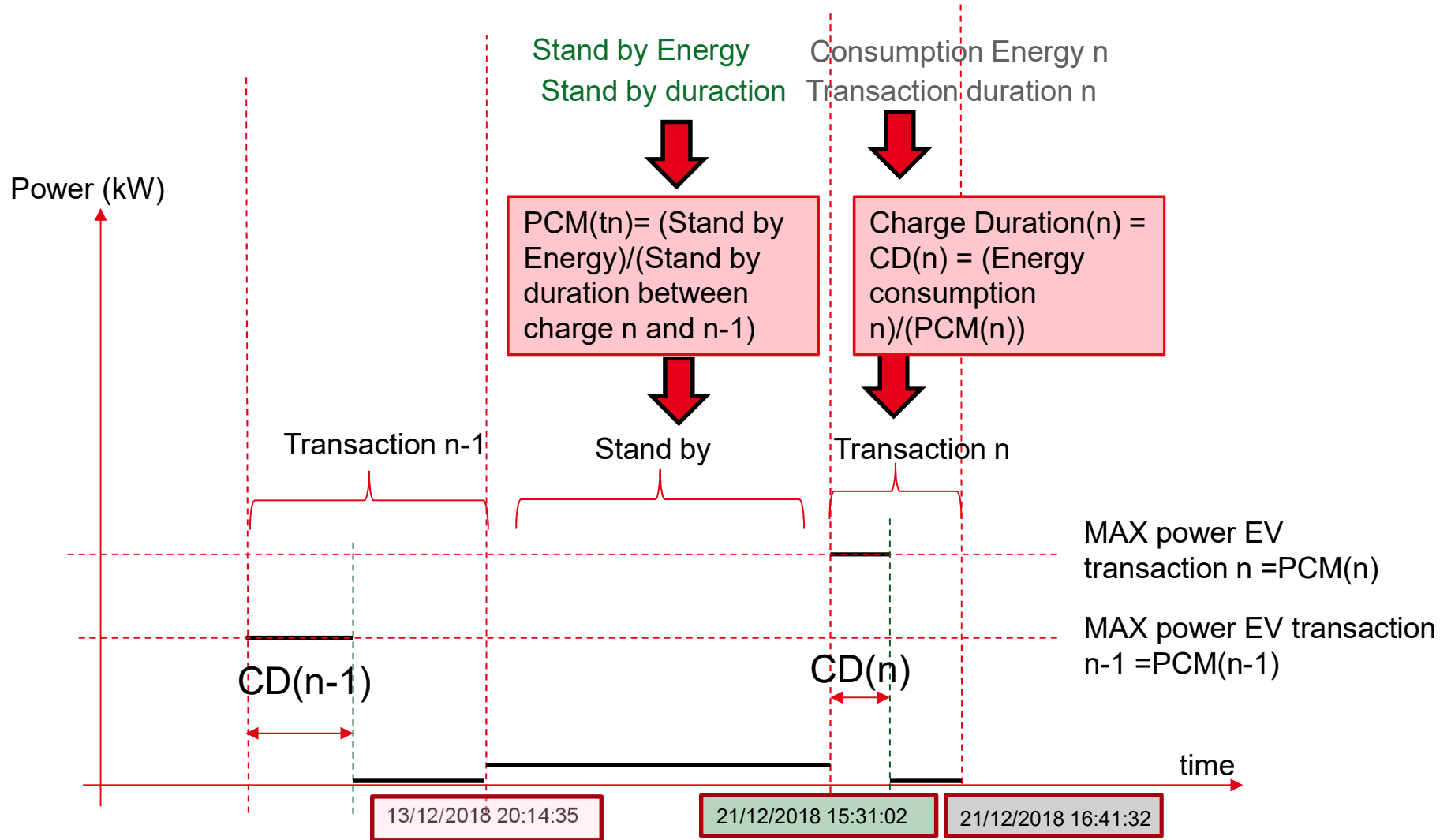

MAX CHARGING POWER HYP. : PRINCIPLES OF RECONSTRUCTION

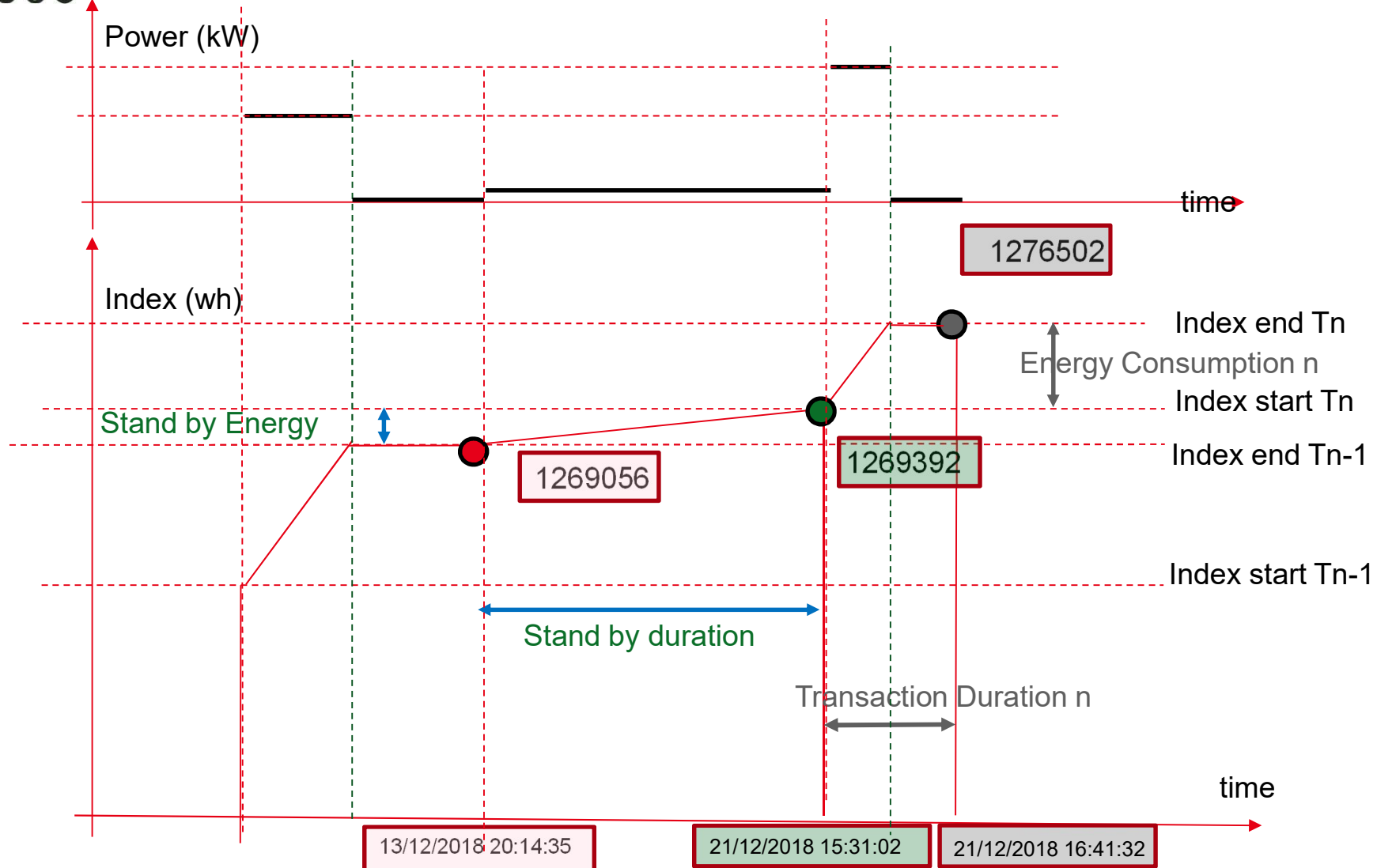

MAX CHARGING POWER HYP. : LOAD CURVES

Charging power curves during 2 weeks:

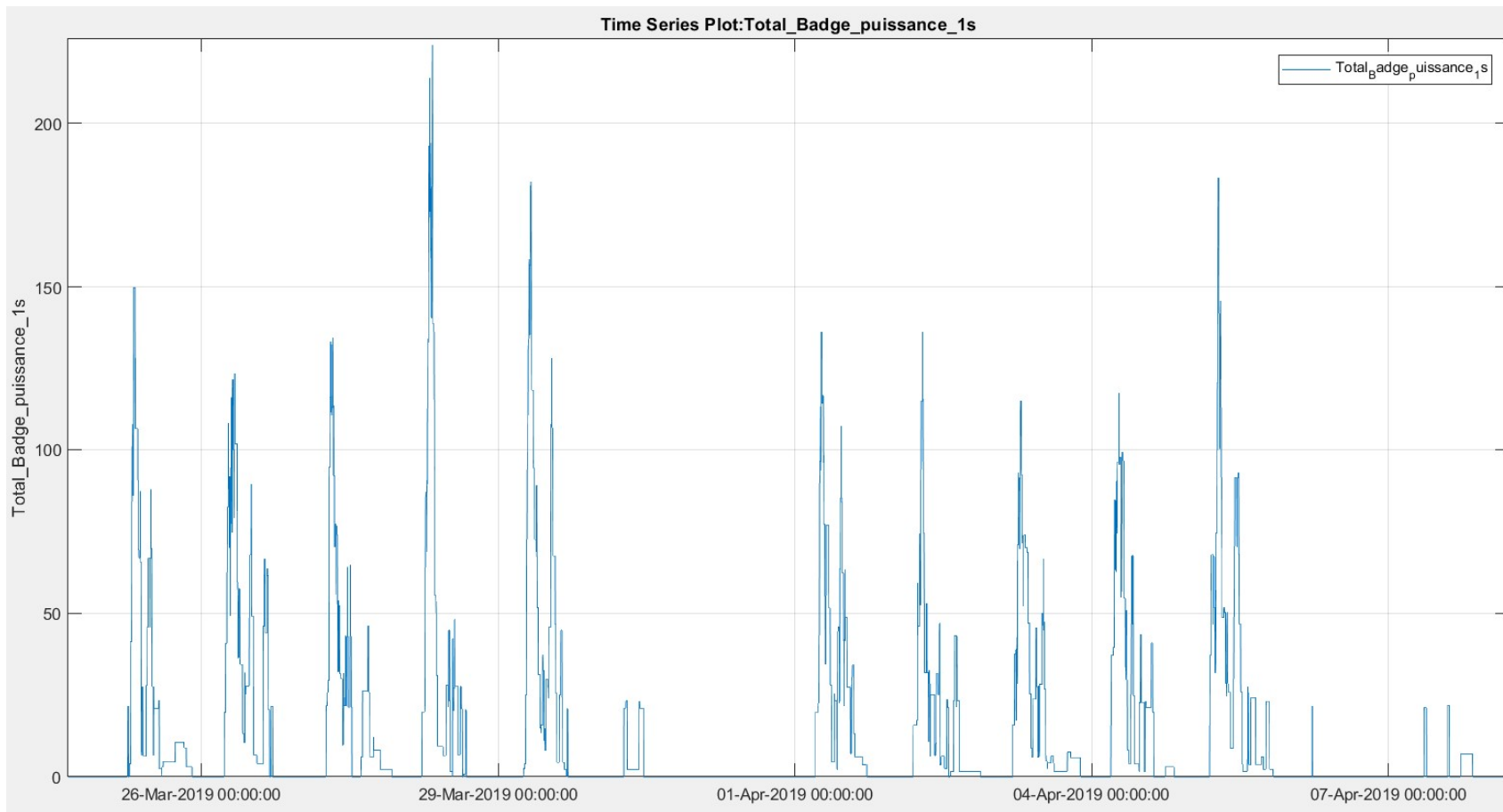

Charging power curves during 3.5 years:

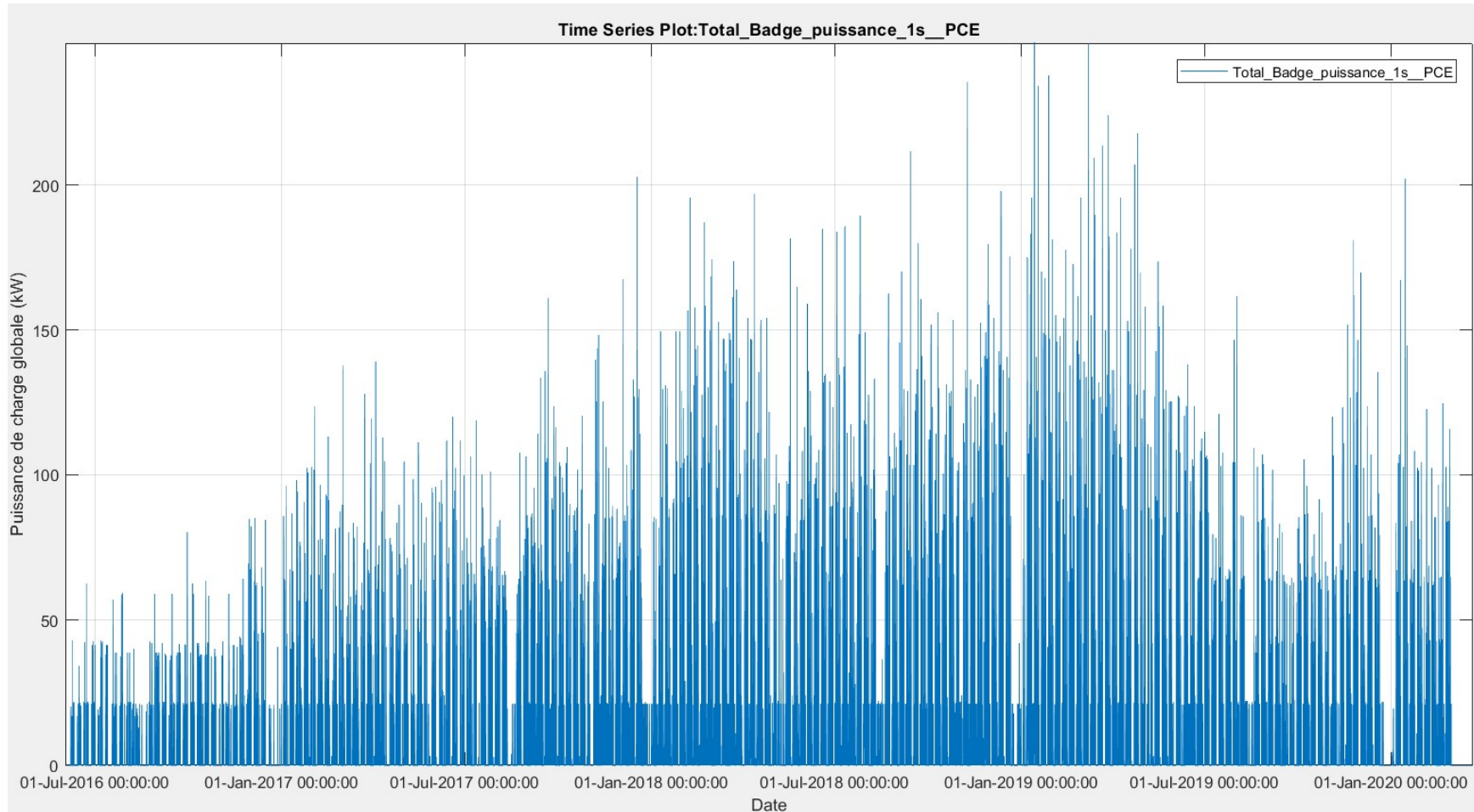

MAX CHARGING POWER HYP. : MEAN LOAD CURVES PER HOUR

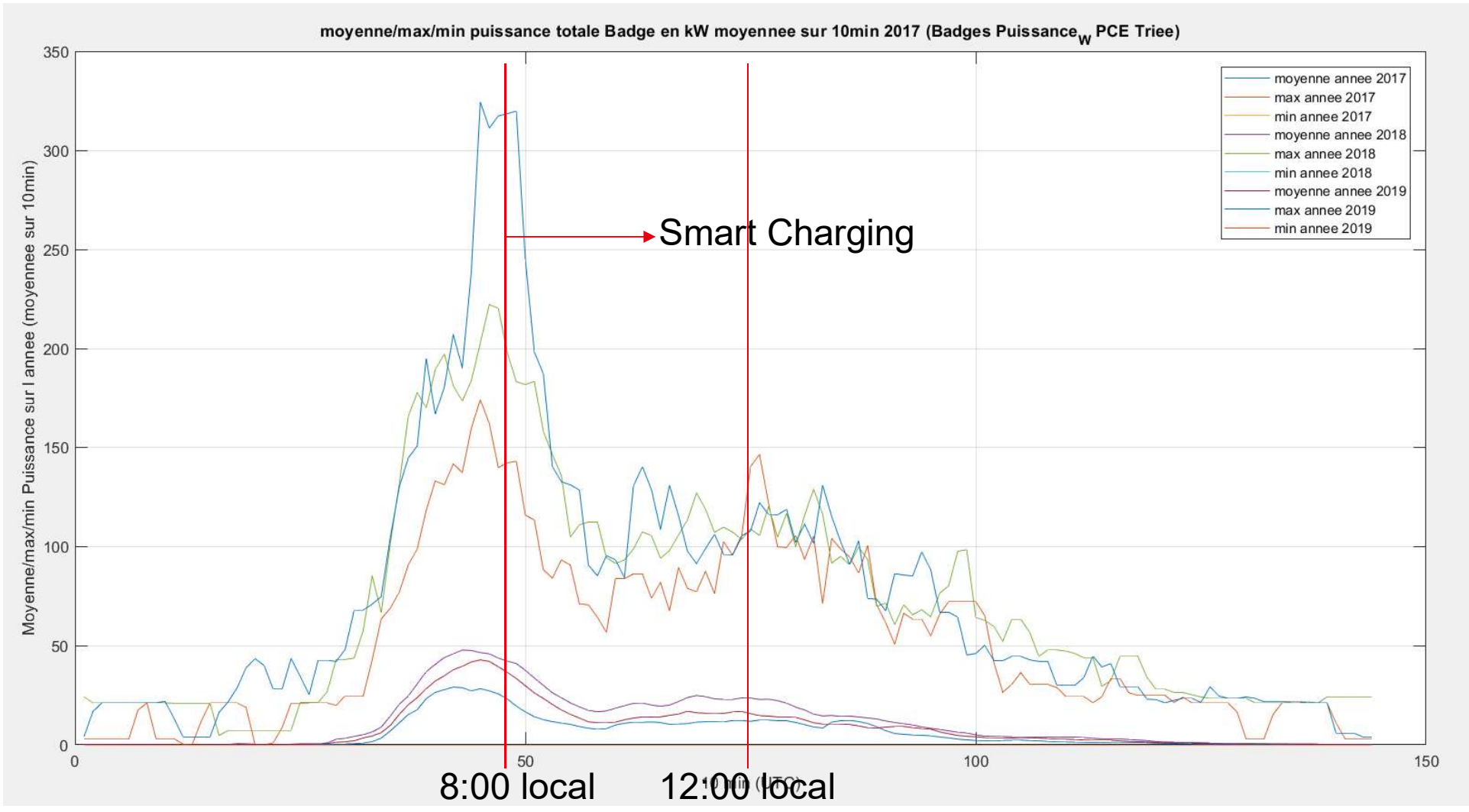

- **EvoIVE Project**
- **CEA EVCI & PV**
 - CEA EVCI
 - Charging modes
 - EvoIVE @INES
 - EvoIVE @Cadarache
- **Transaction analysis**
 - Transactions
 - Energy Consumption v. Transaction Duration (EC v. TD)
 - Flexibility definition & estimation
 - Beginning / end of transactions
- **Load curves**
 - Reconstruction
 - Analysis
- **Smart charging**
 - IT infrastructure
 - Autoconsumption rate
 - Examples of simulation results
 - First experimental results

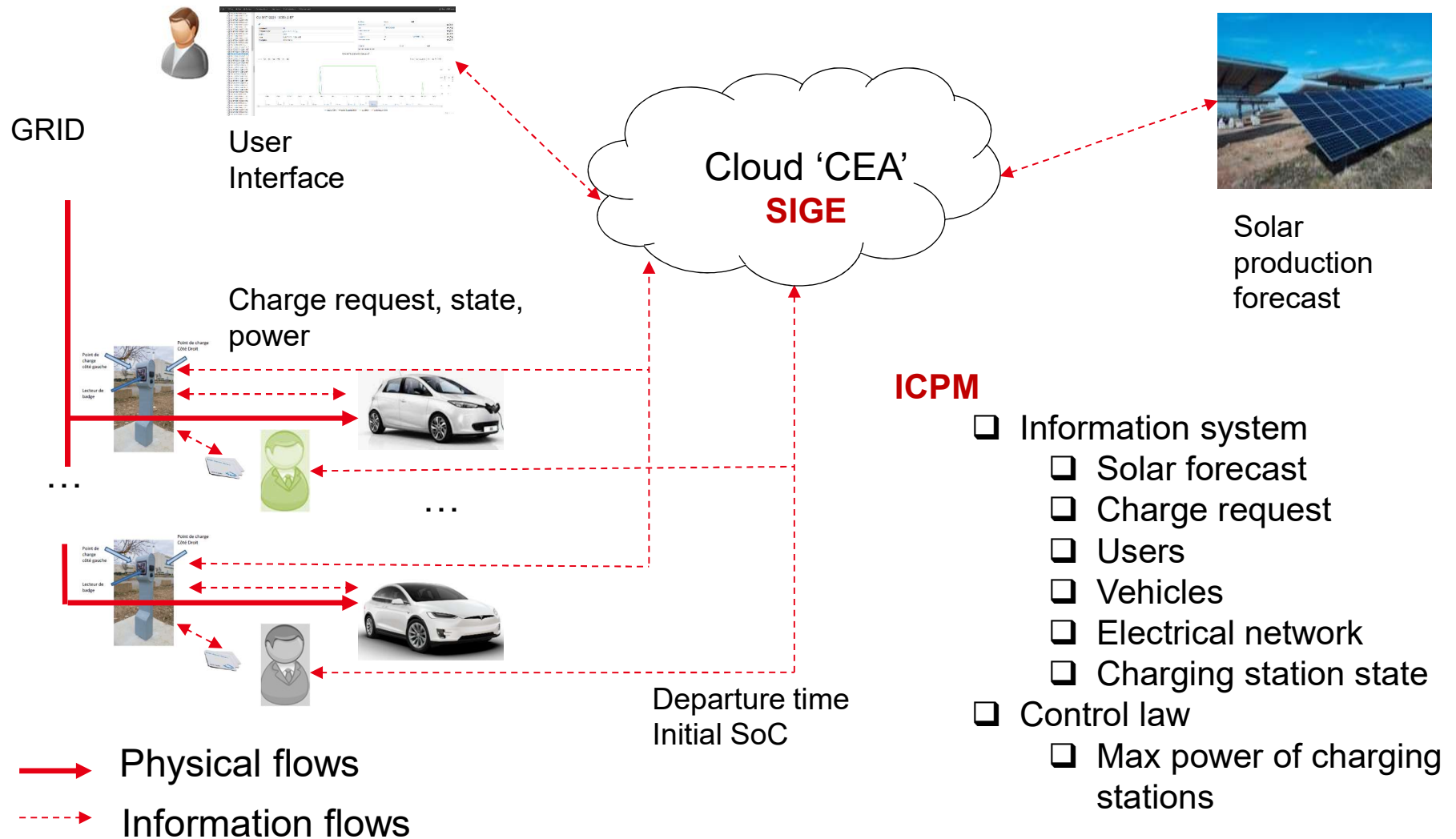



EV

IEC 61851



NFC
Mifare 1k



Badge

Ocpp
protocol

Zigbee

Energy,
Power,
#Badge

G2box

Gateway

Production
forecast

IRVE
management
and analysis



SMS

Departure time
Initial SoC



3G

3G

Tcp/IP



EV user

Graphical User Interface

- The user connects his EV and passes his badge
- The supervision software sends an SMS inviting the user to confirm his departure time and the SOC of his car (default values are proposed).
- The EV is supplied with a test profile.
- Optimization and recharging are made on the basis of these data

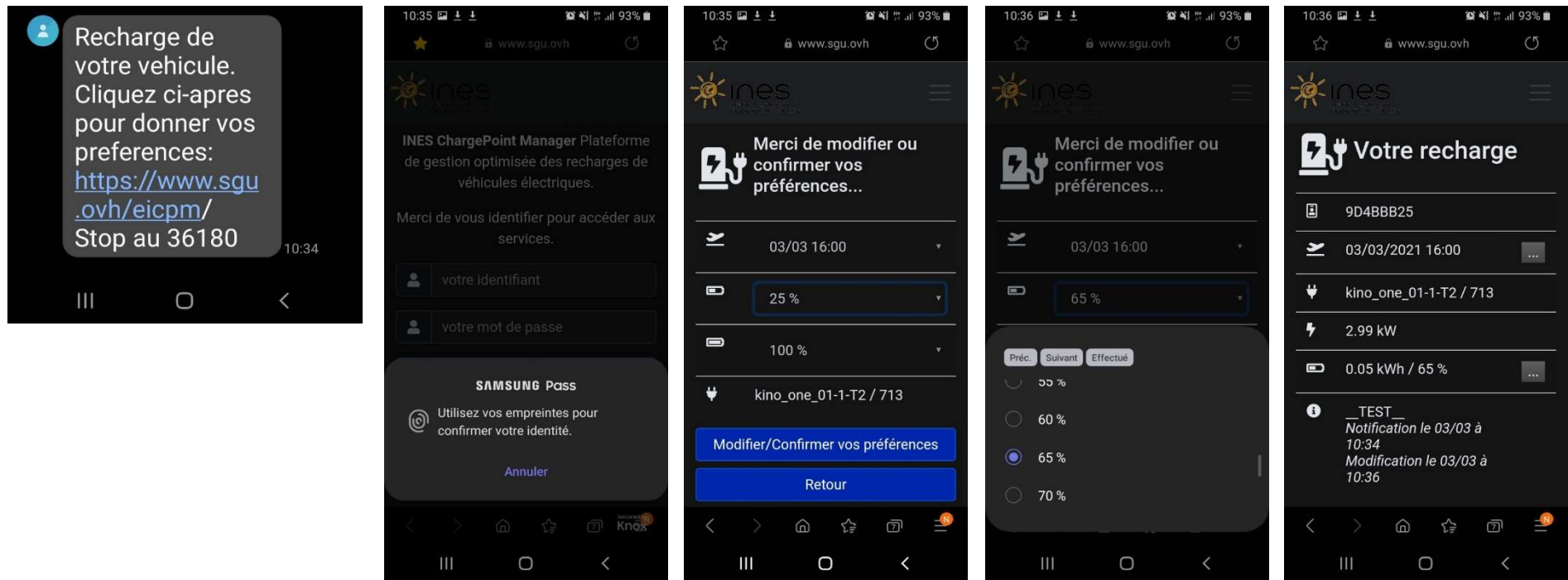

Users and EVs database



PV Plant

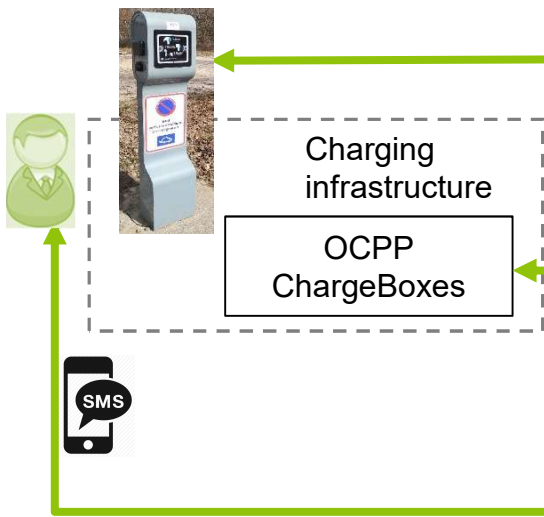

SIGE

Input module

evsem

EV User interface

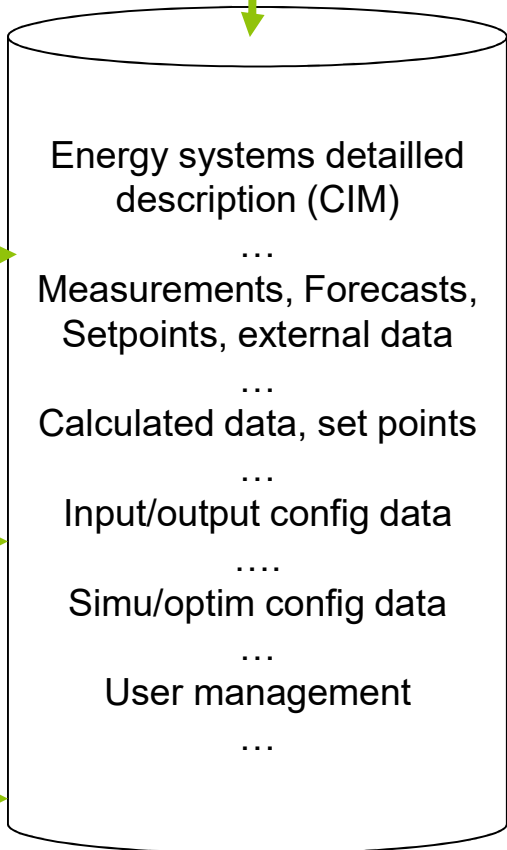

Web portal

API – Application Programming Interface

Set up
Follow up
Results analysis

Simulation

Optimisation

Ad hoc analysis (/battery ageing)

RECALL AUTOCONSUMPTION/AUTOPRODUCTION

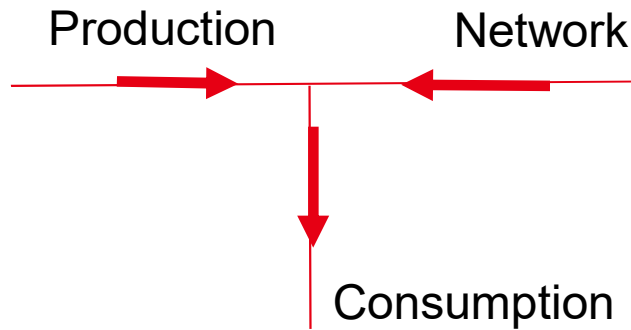

Network + Production = Consumption

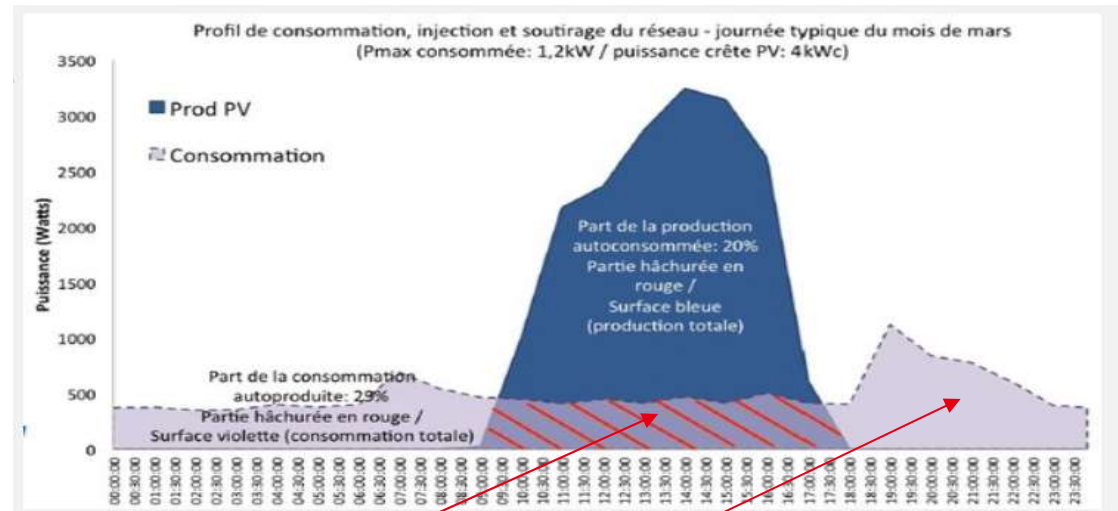

Optimisation process: maximize

selfproduction rate = (PV&consumption)/consumption

View « state of the EVC »

sigE Map Reference data Administration Development Super USER (root)

<p>Batiment 101 - 1 [5670]</p> <ul style="list-style-type: none"> CU-BAT1011-13CEA-1 CU-BAT1011-13CEA-2 CU-BAT1011-13CEA-3 CU-BAT1011-13CEA-4 	<p>Batiment 101 - 2 [5691]</p> <ul style="list-style-type: none"> CU-BAT1012-13CEA-1 CU-BAT1012-13CEA-2 	<p>Batiment 103 - 1 [5698]</p> <ul style="list-style-type: none"> CU-BAT1021-13CEA-1 CU-BAT1021-13CEA-2 CU-BAT1021-13CEA-3 CU-BAT1021-13CEA-4 CU-BAT1021-13CEA-5 CU-BAT1021-13CEA-6 	<p>Batiment 104 - 1 [5717]</p> <ul style="list-style-type: none"> CU-BAT1041-13CEA-1 CU-BAT1041-13CEA-2 CU-BAT1021-13CEA-3 CU-BAT1021-13CEA-4 CU-BAT1021-13CEA-5 CU-BAT1021-13CEA-6 	<p>Batiment 104 - 1 [5717]</p> <ul style="list-style-type: none"> CU-BAT1041-13CEA-1 CU-BAT1041-13CEA-2 	<p>Batiment 106 - 1 [5822]</p> <ul style="list-style-type: none"> CU-BAT2301-13CEA-1 CU-BAT2301-13CEA-2 CU-BAT2301-13CEA-3 CU-BAT2301-13CEA-4 	<p>Batiment 1222 - 1 [5724]</p> <ul style="list-style-type: none"> CU-BAT12221-13CEA-1 CU-BAT12221-13CEA-2 CU-BAT12221-13CEA-3 CU-BAT12221-13CEA-4 	<p>Batiment 151 - 1 [5737]</p> <ul style="list-style-type: none"> CU-BAT1511-13CEA-1 CU-BAT1511-13CEA-2 CU-BAT1511-13CEA-3 CU-BAT1511-13CEA-4 CU-BAT1511-13CEA-5 CU-BAT1511-13CEA-6 	<p>Batiment 155 - 1 [5756]</p> <ul style="list-style-type: none"> CU-BAT1551-13CEA-1 CU-BAT1551-13CEA-2 CU-BAT1551-13CEA-3 CU-BAT1551-13CEA-4 	<p>Batiment 155 - 1 [5756]</p> <ul style="list-style-type: none"> CU-BAT1551-13CEA-1 CU-BAT1551-13CEA-2 CU-BAT1551-13CEA-3 CU-BAT1551-13CEA-4 	<p>Batiment 156 - 1 [5769]</p> <ul style="list-style-type: none"> CU-BAT1511-13CEA-6 	<p>Batiment 155 - 1 [5756]</p> <ul style="list-style-type: none"> CU-BAT1551-13CEA-1 CU-BAT1551-13CEA-2 CU-BAT1551-13CEA-3 CU-BAT1551-13CEA-4 	<p>Batiment 156 - 1 [5769]</p> <ul style="list-style-type: none"> CU-BAT1581-13CEA-1 CU-BAT1581-13CEA-2 	<p>Batiment 202 - 1 [5988]</p> <ul style="list-style-type: none"> CU-BATB61-13CEA-1 CU-BATB61-13CEA-2 	<p>Batiment 218 - 1 [5776]</p> <ul style="list-style-type: none"> CU-BAT2161-13CEA-1 CU-BAT2161-13CEA-2 	<p>Batiment 219 - 1 [5783]</p> <ul style="list-style-type: none"> CU-BAT2191-13CEA-1 CU-BAT2191-13CEA-2 	<p>Batiment 223 - 1 [5790]</p> <ul style="list-style-type: none"> CU-BAT2231-13CEA-1 CU-BAT2231-13CEA-2 CU-BAT2231-13CEA-3 CU-BAT2231-13CEA-4 CU-BAT2231-13CEA-5 CU-BAT2231-13CEA-6 CU-BAT2231-13CEA-7 CU-BAT2231-13CEA-8 	<p>Batiment 225 - 1 [5815]</p> <ul style="list-style-type: none"> CU-BAT2241-13CEA-1 CU-BAT2241-13CEA-2 CU-BAT2231-13CEA-5 CU-BAT2231-13CEA-6 CU-BAT2231-13CEA-7 CU-BAT2231-13CEA-8 	<p>Batiment 225 - 1 [5815]</p> <ul style="list-style-type: none"> CU-BAT2241-13CEA-1 CU-BAT2241-13CEA-2 	<p>Batiment 238 - 1 [5835]</p> <ul style="list-style-type: none"> CU-BAT2381-13CEA-1 CU-BAT2381-13CEA-2 CU-BAT2381-13CEA-3 CU-BAT2381-13CEA-4 	<p>Batiment 278 - 1 [5846]</p> <ul style="list-style-type: none"> CU-BAT2781-13CEA-1 CU-BAT2781-13CEA-2 CU-BAT2781-13CEA-3 CU-BAT2781-13CEA-4 	<p>Batiment 312 - 1 [5861]</p> <ul style="list-style-type: none"> CU-BAT3121-13CEA-1 CU-BAT3121-13CEA-2 	<p>Batiment 313 - 1 [5868]</p> <ul style="list-style-type: none"> CU-BAT3131-13CEA-1 CU-BAT3131-13CEA-2 CU-BAT3131-13CEA-3 CU-BAT3131-13CEA-4 	<p>Batiment 315 - 1 [5881]</p> <ul style="list-style-type: none"> CU-BAT3151-13CEA-1 CU-BAT3151-13CEA-2 CU-BAT3151-13CEA-3 CU-BAT3151-13CEA-4 CU-BAT3131-13CEA-3 	<p>Batiment 315 - 1 [5881]</p> <ul style="list-style-type: none"> CU-BAT3151-13CEA-1 CU-BAT3151-13CEA-2 CU-BAT3151-13CEA-3 CU-BAT3151-13CEA-4 	<p>Batiment 326 - 1 [5894]</p> <ul style="list-style-type: none"> CU-BAT3261-13CEA-1 CU-BAT3261-13CEA-2 	<p>Batiment 351 - 1 [5901]</p> <ul style="list-style-type: none"> CU-BAT3511-13CEA-1 CU-BAT3511-13CEA-2 CU-BAT3511-13CEA-3 CU-BAT3511-13CEA-4 	<p>Batiment 352 - 1 [5914]</p> <ul style="list-style-type: none"> CU-BAT3521-13CEA-1 CU-BAT3521-13CEA-2 	<p>Batiment 519 - 1 [5928]</p> <ul style="list-style-type: none"> CU-BAT5191-13CEA-1 CU-BAT5191-13CEA-2 CU-BAT5191-13CEA-3 CU-BAT5191-13CEA-4 	<p>Batiment 519 - 1 [5928]</p> <ul style="list-style-type: none"> CU-BAT5191-13CEA-1 CU-BAT5191-13CEA-2 CU-BAT7821-13CEA-1 CU-BAT7821-13CEA-2 CU-BAT7821-13CEA-3 CU-BAT7821-13CEA-4 	<p>Batiment 817 [5948]</p> <ul style="list-style-type: none"> CU-BAT817-13CEA-1 CU-BAT817-13CEA-2 	<p>Batiment 837 - 1 [5955]</p> <ul style="list-style-type: none"> CU-BAT8371-13CEA-1 CU-BAT8371-13CEA-2 CU-BAT8371-13CEA-3 CU-BAT8371-13CEA-4 CU-BAT8371-13CEA-5 CU-BAT8371-13CEA-6 	<p>Batiment 904 - 1 [5974]</p> <ul style="list-style-type: none"> CU-BAT9041-13CEA-1 CU-BAT9041-13CEA-2 	<p>Batiment 911 - 1 [5981]</p> <ul style="list-style-type: none"> CU-BAT9111-13CEA-1 CU-BAT9111-13CEA-2 	<p>Batiment XXX [5995]</p> <ul style="list-style-type: none"> CU-BATXXX-13CEA-1 CU-BATXXX-13CEA-2 CU-BATXXX-13CEA-3 CU-BATXXX-13CEA-4
---	---	---	---	---	---	--	---	---	---	---	---	---	---	---	---	---	---	---	---	---	---	---	---	---	---	---	---	---	---	---	---	---	---	---

1 2 3 4 5

View « PV plant »



View « charging station functioning »



Simulation results

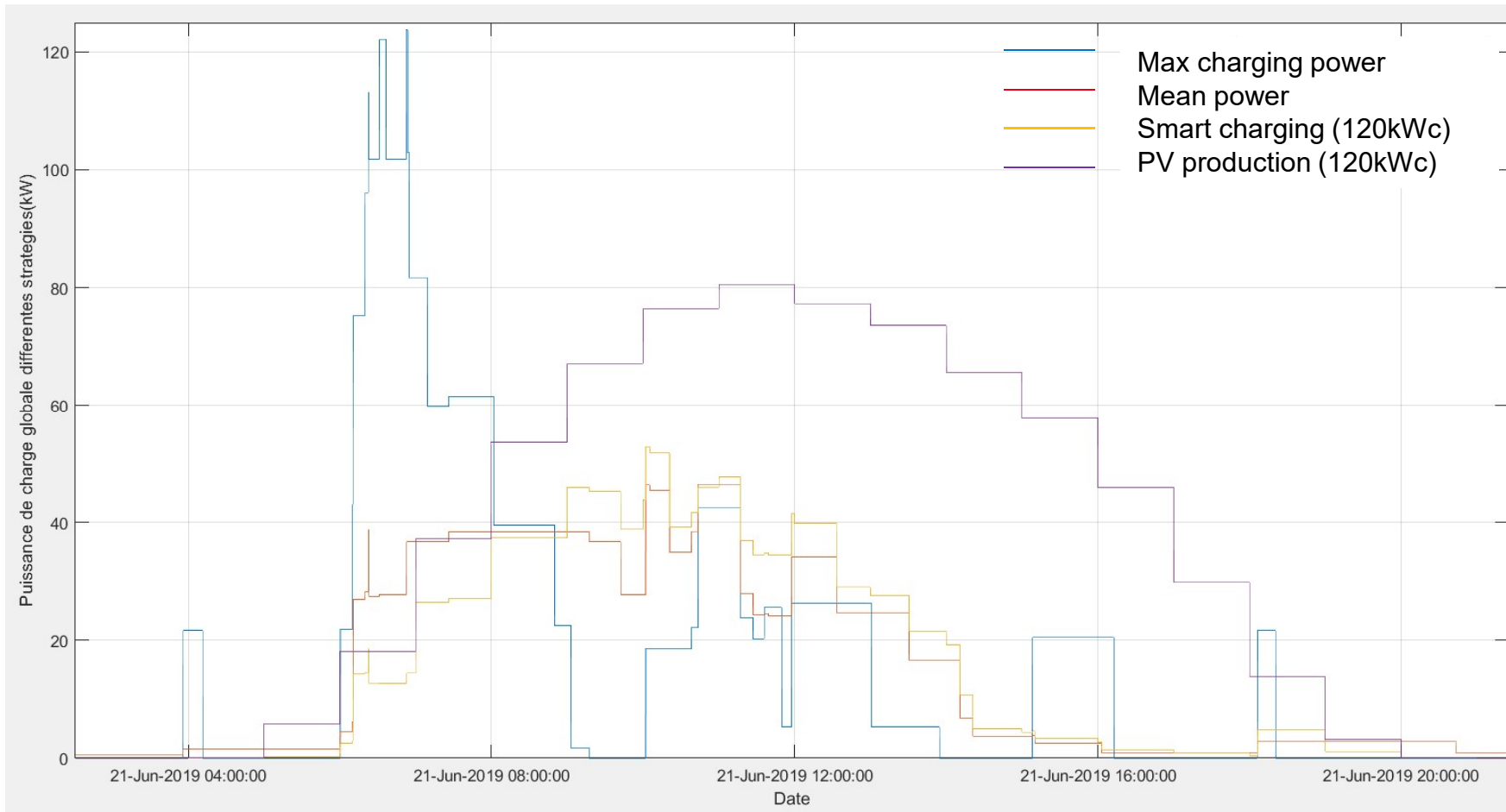



Zoé 22kWh (43kW) Zoé 40kWh (22kW)

Energy Monitor

Voltage	231 231 230 V
Current	15,17 15,33 15,23 A
RealPower PowerFactor	8,80 kW 83,5 %
Energy (present session)	6,89 kWh

Web portal of the charging station

User web interface

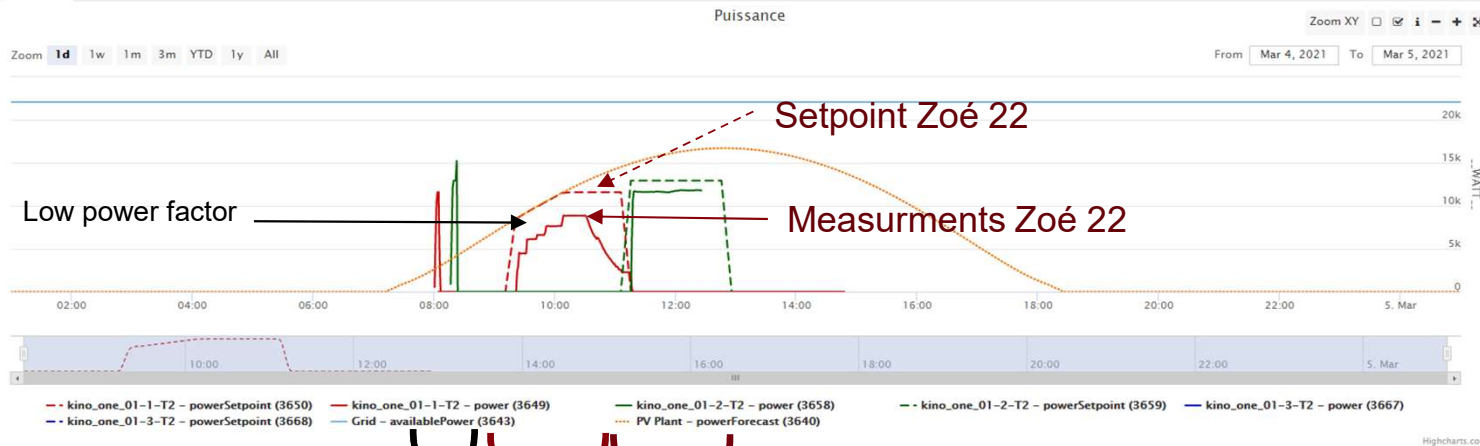
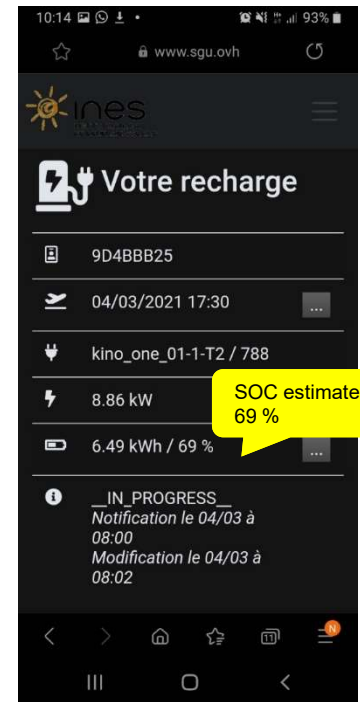

« Test » Charge Zoé 40
Charge Zoé 22

- [1] http://www.hrvojepandzic.com/wp-content/uploads/2019/09/Lecture_4_EVs.pdf
- [2] http://ev-institute.com/images/charged_mag.pdf
- [3] <https://www.transportenvironment.org/what-we-do/electric-cars/how-clean-are-electric-cars>

NEEMO

Networking for Excellence in Electric Mobility Operations

www.NEEMO-project.eu

@NEEMOproject



Thank you for your attention



The project has received funding from the European Union's Horizon 2020 research and innovation programme under grant agreement No 857484