



HAL
open science

Very High Brightness, High Resolution CMOS Driving Circuit for Microdisplay in Augmented Reality

Margaux Vigier, Thomas Pilloix, Bertrand Dupont, Guillaume Moritz

► **To cite this version:**

Margaux Vigier, Thomas Pilloix, Bertrand Dupont, Guillaume Moritz. Very High Brightness, High Resolution CMOS Driving Circuit for Microdisplay in Augmented Reality. MWSCAS 2020 - IEEE 63rd International Midwest Symposium on Circuits and Systems, Aug 2020, Springfield, United States. pp.876-879, 10.1109/MWSCAS48704.2020.9184480 . cea-02953371

HAL Id: cea-02953371

<https://cea.hal.science/cea-02953371>

Submitted on 30 Sep 2020

HAL is a multi-disciplinary open access archive for the deposit and dissemination of scientific research documents, whether they are published or not. The documents may come from teaching and research institutions in France or abroad, or from public or private research centers.

L'archive ouverte pluridisciplinaire **HAL**, est destinée au dépôt et à la diffusion de documents scientifiques de niveau recherche, publiés ou non, émanant des établissements d'enseignement et de recherche français ou étrangers, des laboratoires publics ou privés.



Document Title	Very High Brightness, High Resolution CMOS Driving Circuit for Microdisplay in Augmented Reality
Authors	Margaux VIGIER, Thomas PILLOIX, Bertrand DUPONT, Guillaume MORITZ ^a Université Grenoble Alpes, CEA-LETI, Minatec Campus
Issue date	August 9, 2020
Journal	2020 IEEE 63rd International Midwest Symposium on Circuits and Systems (MWSCAS)
Doi	10.1109/MWSCAS48704.2020.9184480
Acknowledgment	This project has received funding from the Clean Sky 2 Joint Undertaking under the European Union's Horizon 2020 research and innovation programme under grant agreement No 755497.
Disclaimer	The content of this article reflects only the author's view. The Clean Sky Joint Undertaking is not responsible for any use that may be made of the information it contains.

Very High Brightness, High Resolution CMOS Driving Circuit for Microdisplay in Augmented Reality

Margaux VIGIER, Thomas PILLOIX, Bertrand DUPONT, Guillaume MORITZ
Univ. Grenoble Alpes, CEA LETI, Minatec Campus, Grenoble, France
Email: {margaux.vigier,thomas.pilloix,bertrand.dupont,guillaume.moritz}@cea.fr

Abstract—In augmented reality applications, high brightness at high resolution is crucial to guarantee a good user experience. Explorations on efficient light sources have already been undertaken, and GaN μ LEDs tend to be a good candidate. Nevertheless, micro-display driving circuits usually do not provide sufficient luminance level to offer good contrast against ambient light. We report the design and fabrication of a GaN LED microdisplay driving circuit enabling, to our knowledge, the highest brightness for such a pixel pitch and resolution. The driving circuit was designed in a $0.18\mu\text{m}$ CMOS process with 1640×1033 resolution. Each LED is controlled individually by a CMOS pixel of $9.5\mu\text{m}$ pitch. A monochrome green microdisplay enables more than WSXGA resolution and can reach $3.8\text{McD}/\text{m}^2$ for a fully ON micro-LED array.

Keywords— microdisplay driving circuit, GaN micro-LED, high brightness, augmented reality, pulse width modulation, HUD, near-to-eye.

I. INTRODUCTION

The trend on devices for virtual and augmented reality increases continuously, requiring high-resolution microdisplays at small pitches. While virtual reality offers a complete immersion, augmented reality aims at merging user environment with a displayed content. Then, augmented reality requires taking into account the environment. A sufficient luminance from microdisplay is one of the challenges to offer contrast against ambient light, and allow a good user experience. Microdisplay with quite mature technology such as LCD, LCoS, micro-mirrors or OLEDs are already marketed, but do not tackle the need for high brightness [1]. Despite the lack of maturity, GaN LED technology could be a good candidate, demonstrating high contrast, high brightness, high efficiency as well as good lifetime [2]. Integration of low-resolution micro-LED GaN arrays with a driving CMOS demonstrated early the feasibility of a high yield and complex driving circuit [3], [4], [5]. Other technology of microdisplay with driving CMOS were presented, and can show high resolution but limited brightness -up to $20\text{kcd}/\text{m}^2$ - [1], [6]. Circuits with micro-LED GaN technology can demonstrate brightness reaching up to $2.2 \cdot 10^7\text{cd}/\text{m}^2$, but on single source measurement, or a limited resolution [7], [8], [9]. Indeed, the challenge of scaling high brightness at high resolution and low pitch induces important power densities. Under those conditions, it is very difficult to guaranty good luminance uniformity across the array, because of voltage drop and lack of headroom for circuit drive.

This work focuses on the design of a CMOS microdisplay control circuit, capable of delivering sufficient

power to enable high luminance at high resolution and reduced pixel pitch, along with an important luminance range, and adapted to GaN micro-LED technology. To our knowledge, this is the first circuit gathering all these aspects together.

The designed CMOS is also suitable for monochrome, bicolor and full color use, with multiple color mode and white temperature tuning. Once again, to our knowledge, this circuit is also the first enabling full color monolithic GaN array control.

II. PROPOSED ARCHITECTURE

A. Microdisplay stack

The microdisplay consists in an array of pixelated GaN micro-LED at $9.5\mu\text{m}$ pitch [10], stacked on top of a CMOS driving circuit (backplane), shown Fig. 1. Depending on final microdisplay application, GaN array can be monochrome green, for very high luminance need, or monochrome blue, combined with conversion layers to obtain a bicolor or a full color microdisplay. CMOS circuit configuration enables adapted polarization depending on desired color mode (see Fig. 1 and detailed CMOS architecture Fig. 7).

Last metal layer in CMOS circuit offers electrical connection in pixel for both anode and cathode. Anode is pixelated individually for each LED, whereas cathode is common for the whole microdisplay, and routed in grid on LED array die. PAD opening on GaN layer, above CMOS IO ring, enables a microdisplay external control, with an electrical connection from PCB to the circuit core via multiple bondings.

B. LED mismatch compensation

As mentioned earlier, GaN LED maturity level has some drawbacks. It can influence directly control circuit architecture. Typically, non-negligible process mismatch is an important concern. Then, it is necessary to apply an individual correction to each LED to ensure good luminance uniformity. Fig. 2 and Fig. 3 show performances from previous GaN μ LED characterizations. Fig. 2 shows the

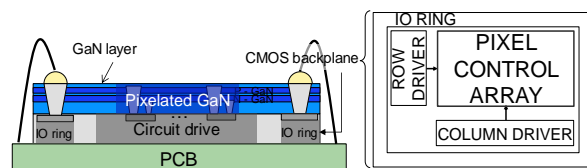

Fig. 1. GaN layer stack with CMOS backplane, and CMOS display circuit drive principle.

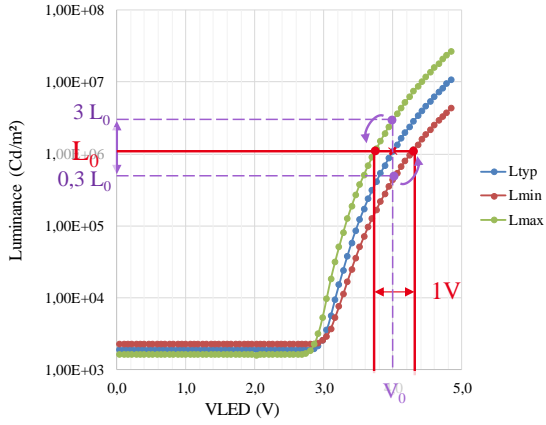

Fig. 2. Measured minimal, maximal and typical luminance versus μ LED voltage for a $8\mu\text{m}$ pitch μ LED

nominal voltage V_0 for a goal luminance L_0 , and 10 times min to max luminance error due to dispersion without correction, for the fixed V_0 .

On Fig. 3, nominal current induces 4 times min-max luminance error on a linear curve, easier to correct. Hence, current correction architecture is chosen. Current control is also a good solution for other emissive technology such as OLED. Evolution of electro-optical characteristics with increased temperature tend to deliver larger current for a constant voltage. Microdisplays with a voltage control will deliver more current, leading to circuit ageing, and could suffer from supply collapse, thus degrading microdisplay performance.

Assuming that luminance uniformity of 10% is not perceptible to human eye, we can deduce current correction range and accuracy. To ensure the 10% uniformity, we chose a harder correction specification of 5%. Then, a 5 bits current correction is enough for required luminance uniformity. Before normal use of microdisplay, a calibration phase will evaluate LED-to-LED dispersion with a 5 bits accuracy. The resulting 5bits mismatch picture will be stored in an external memory, and will define the pixel current polarization later, during a normal use.

C. Pixel Circuit

On the proposed pixel Fig. 4, the transistor P1 and P2 act as current sources. During current initialization, Fig. 5.a, P5 and P6 are turned ON, and P1 and P2 are diode connected. This configuration prevents from error copy due to voltage drop and threshold voltage variations of P1 and P2. According to 5 bits LED correction, a column foot DAC will provide the appropriate current IDAC through P1 and P2. At the end of initialization phase, voltage $V_g(P1, P2)$ is stored in P1 and P2 parasitic capacitor C_{gs1} and C_{gs2} .

In the meantime, a color data is written in the digital memory. To minimize pixel area, grey level information is expressed by binary mode PWM called BCM (for Binary Code Modulation), with an in pixel digital memory. During LED emission phase Fig. 5.b, LED is turned either ON or OFF depending on PWM current bit emission. For a logical '1', LED will be turned ON, with a Luminance value $L(\text{IDAC})$.

During emission phase, LED to LED voltage variation on anode is expected, because of LED process variations. This

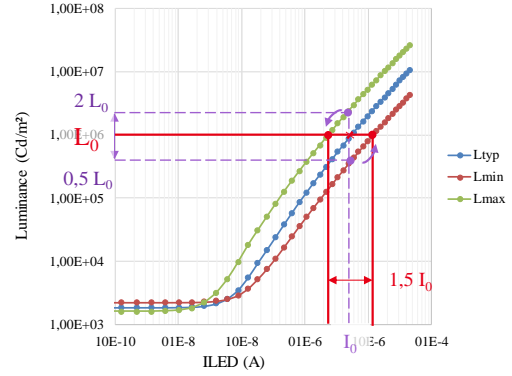

Fig. 3. Measured minimal, maximal and typical luminance versus μ LED current for a $8\mu\text{m}$ pitch μ LED.

may cause an unpredictable $V_{ds}(P1)$ and $V_{ds}(P2)$ variation between initialization and emission phase, leading to current variations, and then luminance non uniformity. To minimize current error from drain to source voltage difference of P1 and P2, current source is cascoded.

Coarse adjustment of microdisplay global luminance is implemented directly in pixel with HIGHL_EN signal. When $\text{HIGHL_EN}='1'$, both P1 and P2 are selected to deliver full current amplitude. When $\text{HIGHL_EN}='0'$, only P2 current source is activated, and drives LED with a lower current depending on P1 and P2 W/L ratio, given by:

$$I_{LED} = I(P2) * [1 + \text{HIGHL_EN} * \frac{W/L(P2)}{W/L(P1)}] \quad (1)$$

Assuming current is linear with luminance, for a chosen high luminance level L_0 , lower luminance only depends on P1 and P2 W/L ratio.

When $\text{HIGHL_EN}='0'$, no current flows through P1. In this luminance mode, gate node voltage $V_g(P2)$ is highly sensitive to variations (flicker or charge injection), because of small storage capacitor C_{gs2} . Proposed pixel architecture uses P1 as a MOS capacitor connected to gate current source $V_g(P2)$ when $\text{HIGHL_EN}='0'$. P2 gate is then loaded by a bigger capacitor than $C_{gs}(P2)$, and lowers gate sense node $V_g(P2)$ sensitivity to variations.

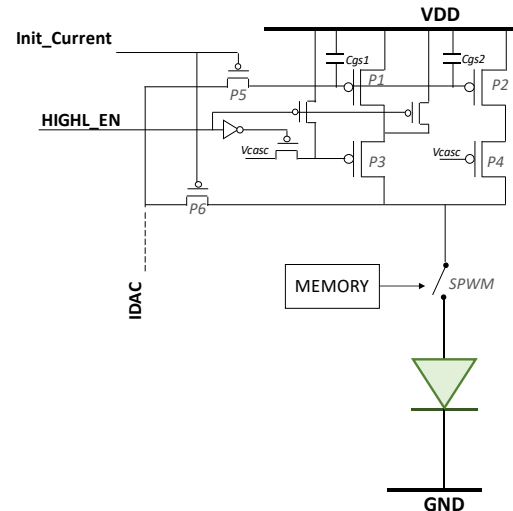

Fig. 4. Pixel architecture

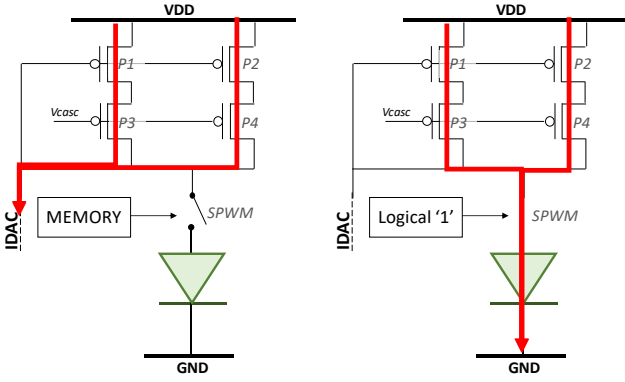

Fig. 5.a) Pixel current initialization phase, example with HIGHL_EN='1'
Fig. 5.b) Pixel emission phase, example with HIGHL_EN='1'

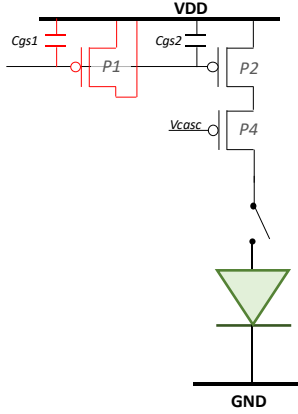

Fig. 6. Pixel equivalent current source in low luminance mode (for HIGHL_EN = '0')

D. Pixel layout

As discussed previously, high brightness microdisplay leads to an important amount of power delivered by CMOS control circuit. Then, power dissipation and voltage drop are both limiting microdisplay performance. Voltage drop will decrease locally supply headroom, and prevent current source from delivering the proper current value, resulting in a decreased luminance in micro-display's center [9]. To mitigate those effects, pixel routing strategy consists in using thick metals and high-density metal routing in pixel. LED common cathode is also electrically connected to CMOS circuit in each pixel, and can benefit from the high density routing strategy, helping to minimize voltage drop. Final pixel pitch is $9.5\mu\text{m}$ (see Fig. 8).

E. Top architecture

CMOS driving circuit comprises a 1640×1033 -pixel array of the presented pixel (see Fig. 4), and its integrated control electronics (see Fig. 7). Row driver acts as a rolling shutter control of the array, enabling row current initialization, memory initialization and micro-LED emission. Row driver also allows a precise dimming function via emission control with PWM switch. Color Data Driver addresses the appropriate color data to the corresponding column. Mismatch data Driver addresses column Current DACs by distribution of the appropriate 5 bits mismatch data to each column DAC.

Each column DAC consists in a 5 bits current steering DAC architecture, with unity current sources pondered depending

on DAC bit. DAC current I_{DAC} derived from classical current steering DAC formula is given by:

$$I_{DAC} = I_0 + \sum_{i=0}^4 \text{Datamismatch}(i) \times I_{LSB} \times 2^i \quad (2)$$

I_0 is the minimal current per pixel, for a given color and luminance mode. I_{LSB} is the DAC unity current. i is the bit weight for mismatch correction.

For example, with a monochrome green microdisplay with configuration HIGHL_EN='1', minimal current I_0 is $5\mu\text{A}$ with Datamismatch[4:0]='00000', and maximal current is $20\mu\text{A}$, with Datamismatch[4:0]='11111'.

Knowing that DAC to DAC current mismatch decreases when WxL of unity current source increases [11], design of DAC cell consisted in a tradeoff between DAC to DAC dispersion, and DAC affordable pitch. The DAC final footprint is $19\mu\text{m} \times 80\mu\text{m}$.

DAC BIAS cell controls the unity DAC current. According to COLOR_MODE[1:0], VBIAS[3:0] will impose same voltage to each VBIAS in monochrome mode, or different value for bicolor and full color mode. Selection of different color current references in DAC BIAS cell enables relative color modification via current ratio tuning. This enables color temperature adjustment, or correction of micro-LED wavelength shift from expected values.

Total circuit footprint is $20\text{mm} \times 14.5\text{mm}$ (Fig. 8).

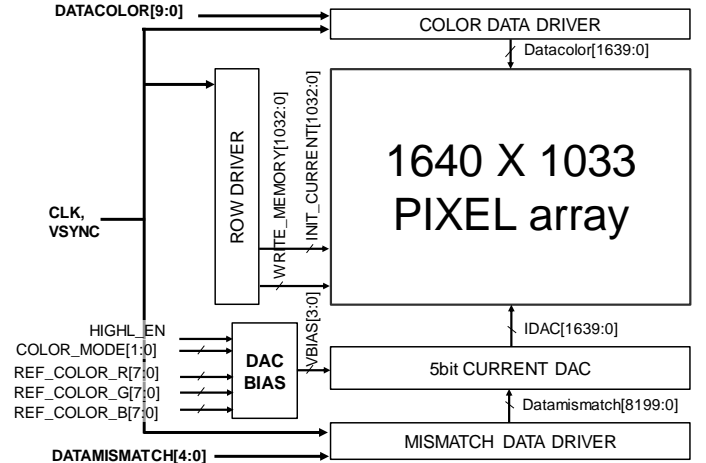

Fig. 7. Top architecture of CMOS driving circuit.

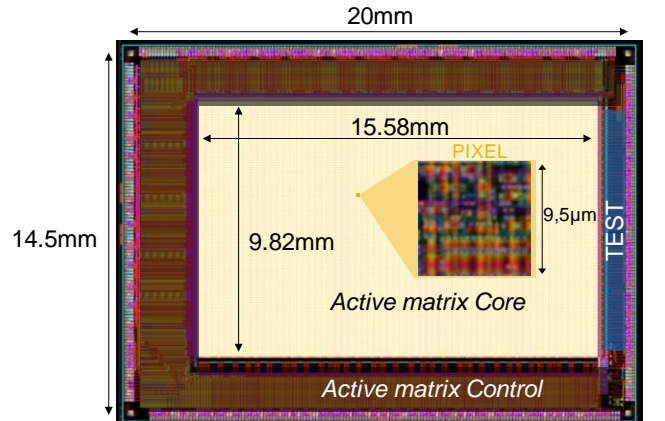

Fig. 8. Top circuit and pixel layout.

III. RESULTS AND DISCUSSION

The curve of Fig. 9 shows the luminance versus supply voltage drop. Voltage drop affects particularly luminance drop for highest pixel current (equivalent to maximal mismatch correction). Under high currents, $V_{sg}(P1)$ and $V_{sd}(P1)$ are more important and suffer from a lack of headroom.

Voltage drop will cause current decrease, and affect luminance uniformity across the array. However, human eye is less sensitive to luminance gradient caused by voltage drop than pixel-to-pixel variation due to LED mismatch. Then, luminance uniformity specification is less constraint than for LED correction calculation, so 15% luminance loss is already acceptable. As soon as total voltage drop does not exceed 950mV, current decrease is under 15%, as well as luminance decrease. Expected voltage drop is 0.27V for ground supply and 0.24V for power supply. Total column voltage drop is $0.51V < 0.95V$. Thus, the whole column can be turned ON with acceptable luminance loss due supply drop.

This is particularly interesting in avionics applications needing high contrast for displaying information or symbology.

Expected luminance for a fully ON monochrome green microdisplay with $20\mu A$ nominal current is $3.8MCd/m^2$ [10].

Expected pixel performances are summarized TABLE I. .

TABLE I. PIXEL SPECIFICATIONS

Pixel specification	Expected results	
	Value	Unit
Max. Brightness	3.8×10^6	cd/m ²
Pixel pitch	9.5	μm
LED mismatch correction	5	bit
Pixel current	5 to 20	μA
Pixel voltage	5.5	V

IV. CONCLUSION

We report the design and fabrication of a CMOS control circuit for a future 1640×1033 array of GaN $\mu LEDs$. To our knowledge, this is the first circuit providing sufficient power to drive micro-LEDs array with a luminance level suitable for outdoor applications. With a monochrome green array of GaN micro-LED, we expect $3.8MCd/m^2$, if the whole array is turned ON at highest luminance. Two analog luminance modes allow a coarse dimming. Thinner dimming adjustment is also possible via PWM duration control. Multi-color mode enables several emissive source nature, with different type of array: monochrome, bicolor, full color. Color temperature can also be adjusted depending on source nature and ageing. This versatile circuit enables multisource usage, and paves the way for further GaN micro-LEDs evolution.

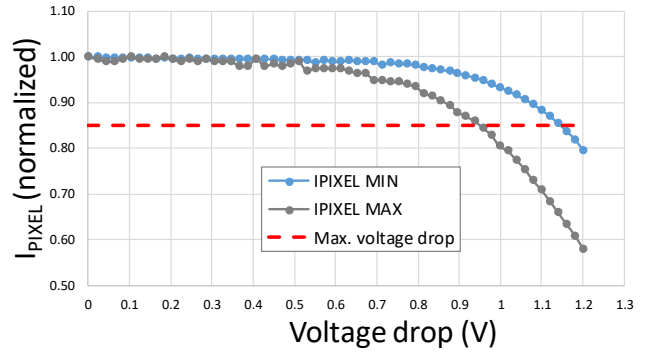

Fig. 9. LED current delivered vs. Supply voltage drop

ACKNOWLEDGMENT

The author acknowledge funding from the CleanSky-H2020 European project (under H2020-EU.3.4.5.6-ITD Systems, Project ID: 755497).

REFERENCES

- [1] V.Gohri et al., "High Brightness Green OLED Microdisplay With High Resolution and Low Power Consumption", *SID Conference Record of the International Display research Conference*, pp.81-84, 2011.
- [2] Z.J.Liu, W.C.Chong, K.M.Wong, K.H.Tam, and K.M.Lau, "A Novel BLU-Free Full-Color LED Projector Using LED on Silicon Micro-Displays", *IEEE Photonics Technology Letters*, vol.25, no.23, pp.2267-2270, 2013.
- [3] Z.J.Liu, K.M.Wong, C.W.Keung, C.W.Tang, and K.M.Lau, "Monolithic LED MicroDisplay on Active Matrix Substrate Using Flip-Chip Technology", *IEEE Journal of Selected Topics in Quantum Electronics*, vol.15, pp.1298-1302, 2009.
- [4] J.J.D.McKendry et al., "Individually Addressable AlInGaNMicro-LED Arrays With CMOS Control and SubNanosecond Output Pulses", *IEEE Photonics Technology Letters*, vol.21, no.12, pp.811-813, 2009.
- [5] F.Templier et al., "High Brightness GaN LED Arrays Hybridized on Silicon Interconnect at a Pixel Pitch of $10\mu m$ ", *Proceedings of the International Display Workshops*, pp.1279-1282, 2014.
- [6] H.S.El-Ghoroury, C.L. Chuang, Z.Y. Alpaslan, "Quantum Photonic Imager (QPI): A novel Technology That enables more than 3D Applications", *SID Symposium Digest of Technical Papers*, vol.46, pp 371-374, 2015.
- [7] F.Templier et al., "GaN based emissive microdisplays: A very promising technology for compact, ultra-high brightness display systems", *Journal of the Society for Information Display*, vol.24, pp.669-675, 2016.
- [8] J.Day, J.Li, D.Y.C.Lie, C.Bradford, J.Y.Lin, H.X.Jiang, "III-Nitride full-scale high-resolution microdisplays", *Applied Physics Letters*, vol.99, pp.031116-031116, 2011.
- [9] J.Herrnsdorf et al., "Active-Matrix GaN Micro Light-Emitting-Diode Display with Unprecedented Brightness", *IEEE Transactions on Electron Devices*, vol.62, no.6, pp.1918-1925, 2015.
- [10] E.Quesnel et al., "Dimensioning a full color LED micro-display for augmented reality headset in a very bright environment", *Journal of the Society for Information Display*, accepted, in press, 2020.
- [11] B.Zhao et al., "An Accurate Current Scaling Circuit for Self-Emissive Microdisplay driving circuit", *2018 14th IEEE International Conference on Solid-State and Integrated Circuit Technology*, pp.1-3, 2018