



HAL
open science

How Advanced EBSD and Accurate-ECCI can be applied to quantify sub-boundaries induced during dislocational creep of UO₂

M. Ben Saada, N. Gey, N. Maloufi, H. Mansour, B. Beausir, X. Iltis

► **To cite this version:**

M. Ben Saada, N. Gey, N. Maloufi, H. Mansour, B. Beausir, et al.. How Advanced EBSD and Accurate-ECCI can be applied to quantify sub-boundaries induced during dislocational creep of UO₂. EBSD Conference 2016, RMS, Mar 2016, Manchester, United Kingdom. cea-02442296

HAL Id: cea-02442296

<https://cea.hal.science/cea-02442296>

Submitted on 16 Jan 2020

HAL is a multi-disciplinary open access archive for the deposit and dissemination of scientific research documents, whether they are published or not. The documents may come from teaching and research institutions in France or abroad, or from public or private research centers.

L'archive ouverte pluridisciplinaire **HAL**, est destinée au dépôt et à la diffusion de documents scientifiques de niveau recherche, publiés ou non, émanant des établissements d'enseignement et de recherche français ou étrangers, des laboratoires publics ou privés.

DE LA RECHERCHE À L'INDUSTRIE



(1)



(2)



www.cea.fr

How advanced EBSD and Accurate-ECCI can be applied to quantify sub-boundaries induced during dislocational creep of UO_2

Mariem Ben Saada^{1,2}

N. Gey², N. Maloufi², H. Mansour², B. Beausir², X. Iltis¹

Email: [Mariem.BENSAADA@cea.fr](mailto:Mariam.BENSAADA@cea.fr)

(1) CEA Cadarache, DEN/DEC/SFER/Laboratoire des Combustibles Uranium, 13108 Saint Paul Lez Durance, France

(2) LEM3, Ile du Saulcy, 57045 Metz, France

Sintered Uranium Dioxide UO_2 pellets are commonly used in nuclear Pressurized Water Reactors (PWR)

The fuel rods consist of:

- (1) UO_2 pellets piled up in
- (2) a zirconium alloy cladding tube cooled by pressurized water

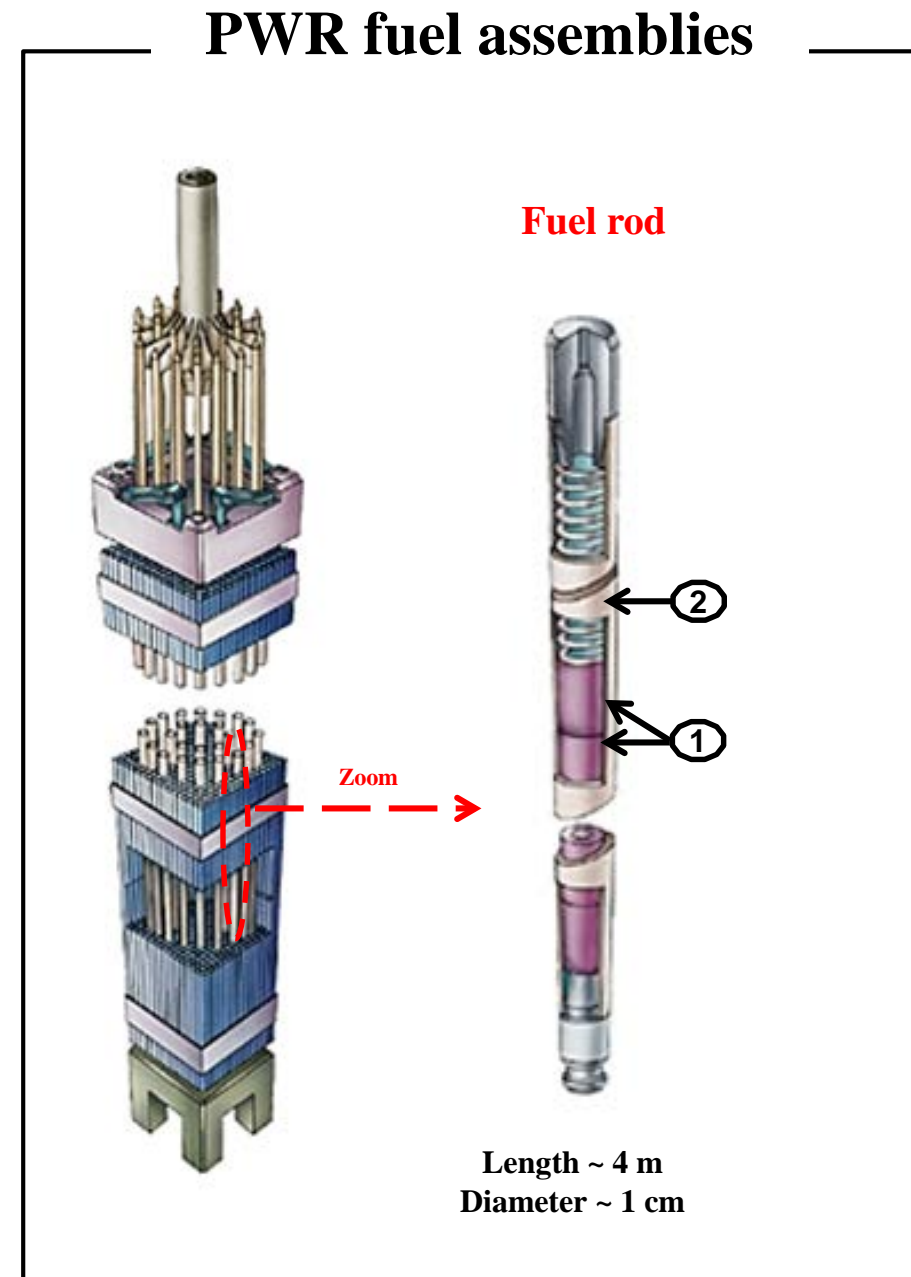

In service the UO_2 pellets undergo significant plastic deformation by creep

Nominal conditions

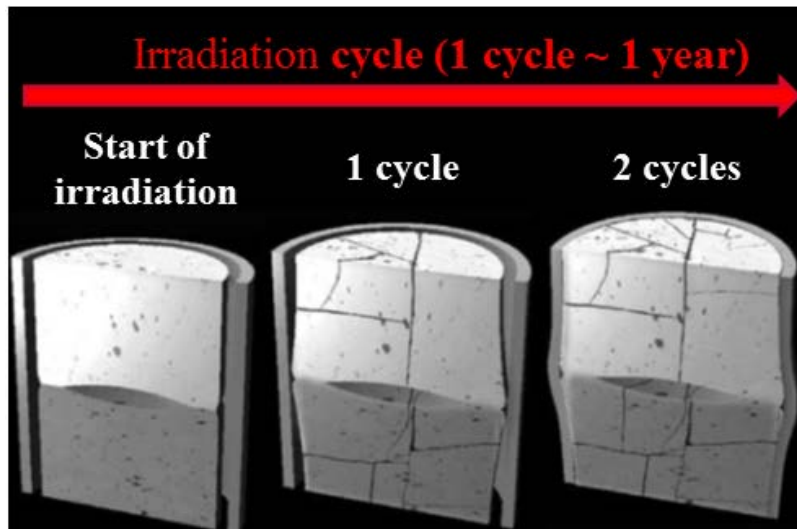

9,5 mm

Under irradiation:

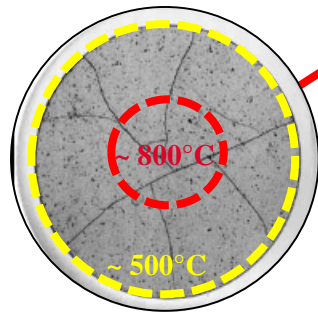

thermal gradient + fission products

→ Fuel swelling

→ Large stresses and cracks in the pellet

Power transient

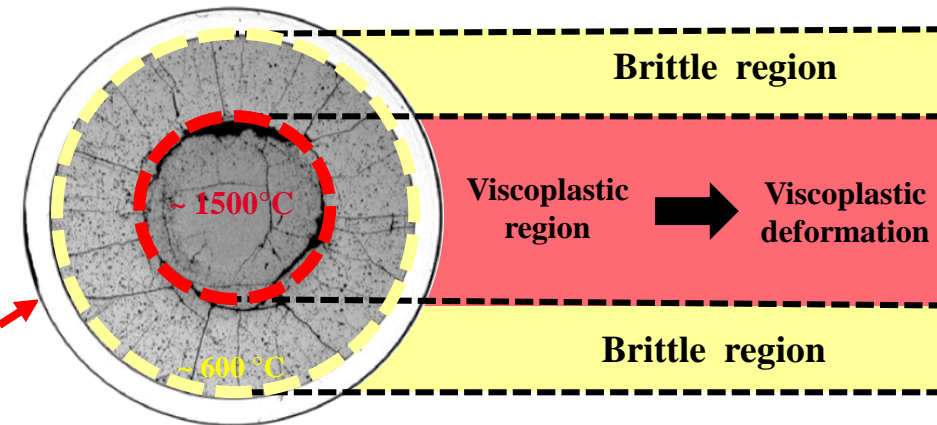

Cracking in a UO_2 pellet subjected to 2 annual PWR cycles, followed by 12 hours at a linear power of 430 W/cm.

Increasing power causes:

- An increase of pellet temperature up to about 1500-2000°C in its central part
→ **Viscoplastic-deformation: Creep of the pellet**

➤ **To avoid cladding failure**

→ Increase the creep of the fuel (viscoplastic deformation)

This creep process is partly reproduced by compression creep tests on non-irradiated UO_2 sintered samples

Grain size : $20\mu m$

Sintering conditions [1,2]

Uniaxial pressing of the powder
under **400 MPa**

+

Sintering heat treatment at **$1900^\circ C$** for
4h, under an atmosphere of **Ar + 5% H_2**

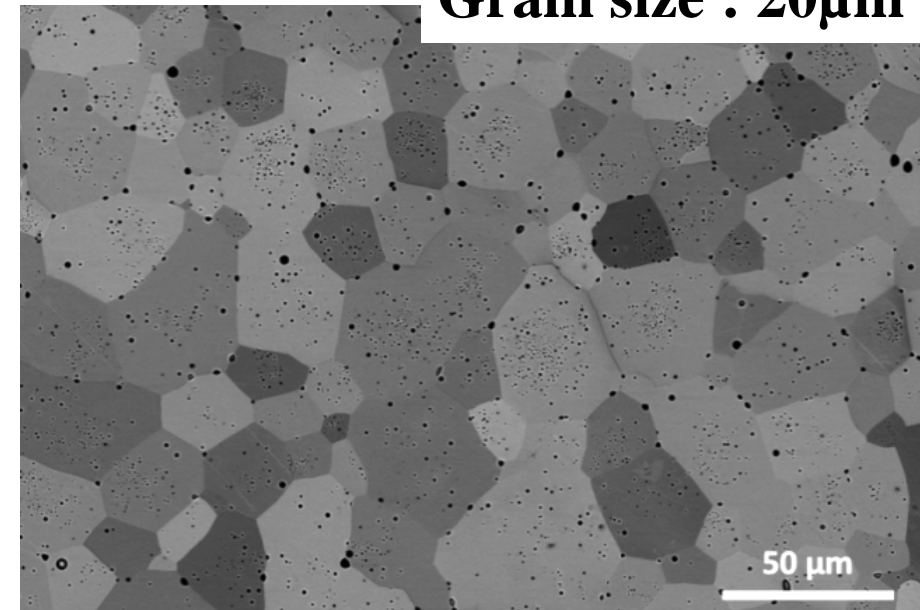

SEM micrograph (BSE mode) of an UO_2 sample

Compression creep tests at $1500^\circ C$ [1,2]

Our reference
sample

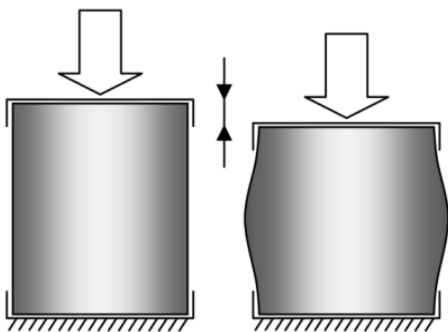

- **50 MPa**
- **test duration: 2.7h**
- **mean deformation: ~ 8%**

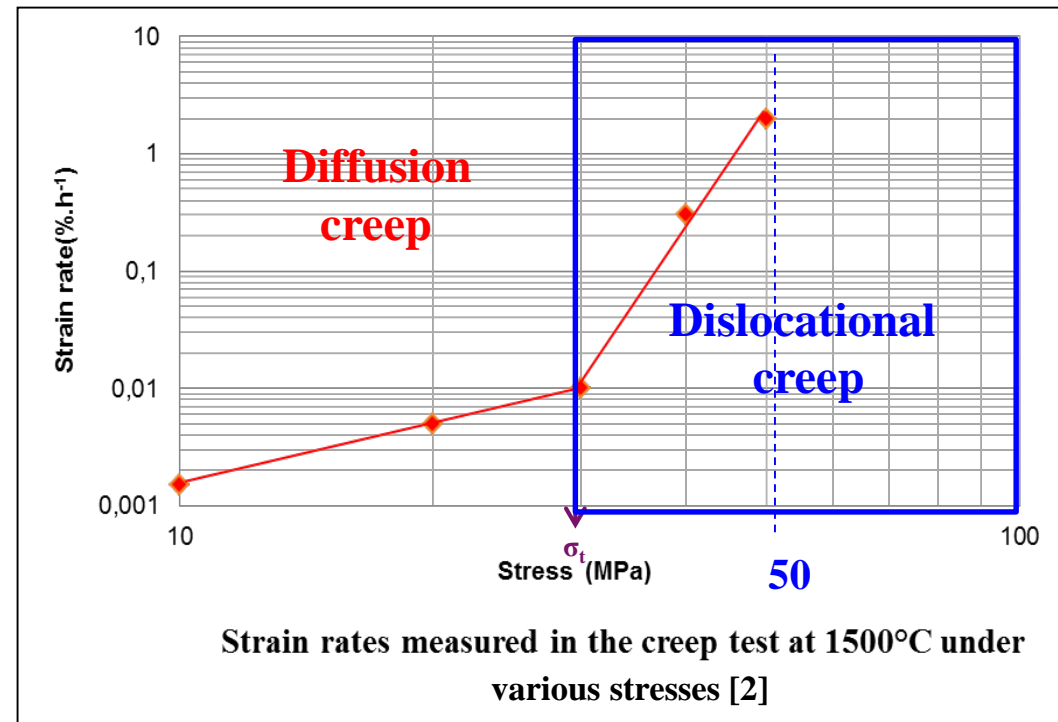

[1]. X. ILTIS, M. BEN SAADA, H. MANSOUR, N. GEY, A. HAZOTTE, N. MALOUFI, A new characterization approach for studying relationships between microstructure and creep damage mechanisms of uranium dioxide, J. of Nuc. Mat. 474 (2016).

[2]. X. ILTIS, N. GEY, C. CAGNA, A. HAZOTTE, Ph. SORNAY, Microstructural evolution of uranium dioxide following compression creep tests : An EBSD and image analysis study, J. of Nuc. Mat. 456 (2015).

Creep damage

- Intergranular cavities
 - Sub-grains formation
 - Dislocations density increase
- **SEM studies**

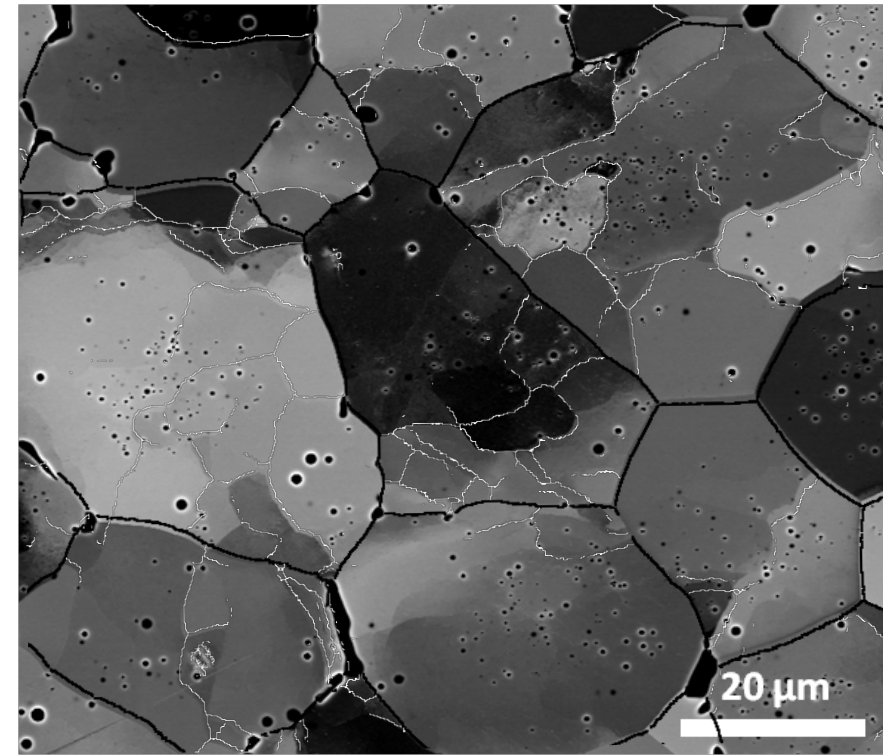

▪ **TEM studies**

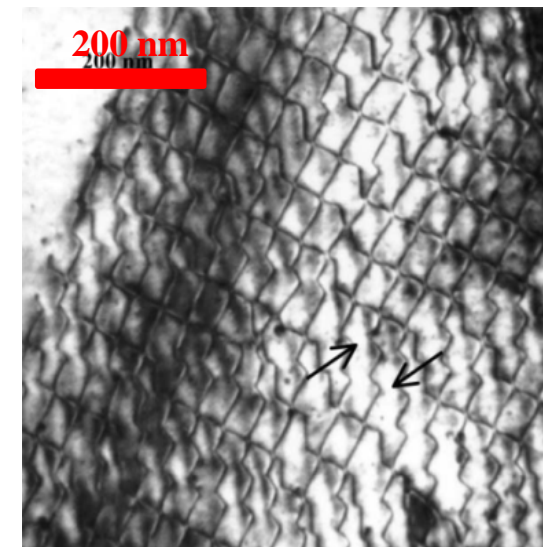
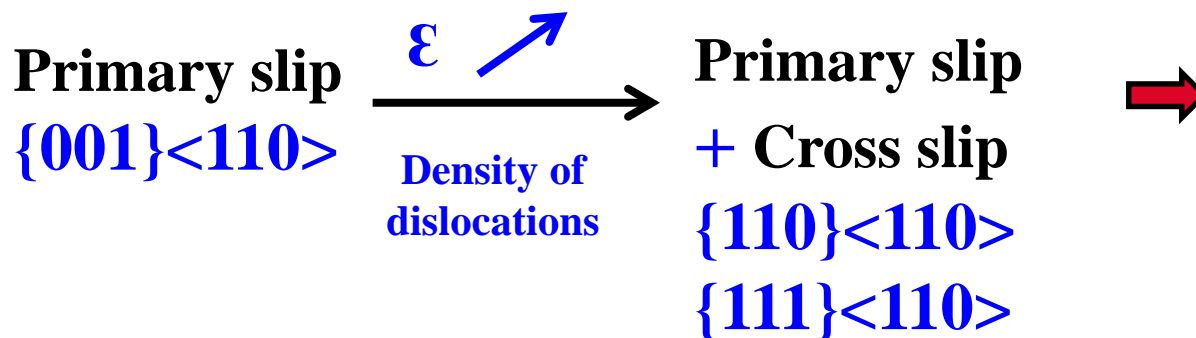
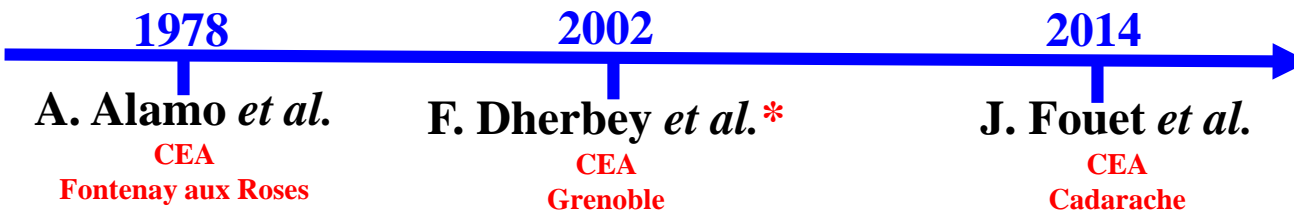

Dislocation network*

EBSD

Electron BackScattered
Diffraction

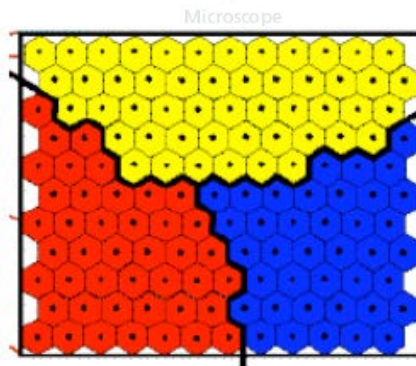
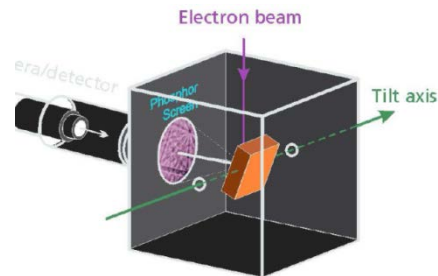

Acquisition of Orientation map to:

- Identify the low angle boundaries (sub-grains),
- Quantify the Geometrically Necessary Dislocations (GND)

BULK MATERIAL SEM

To identify crystallographic defects like dislocations and their arrangement in sub-grains boundaries

A-ECCI

Acurrate Electron Channeling
Contrast Imaging

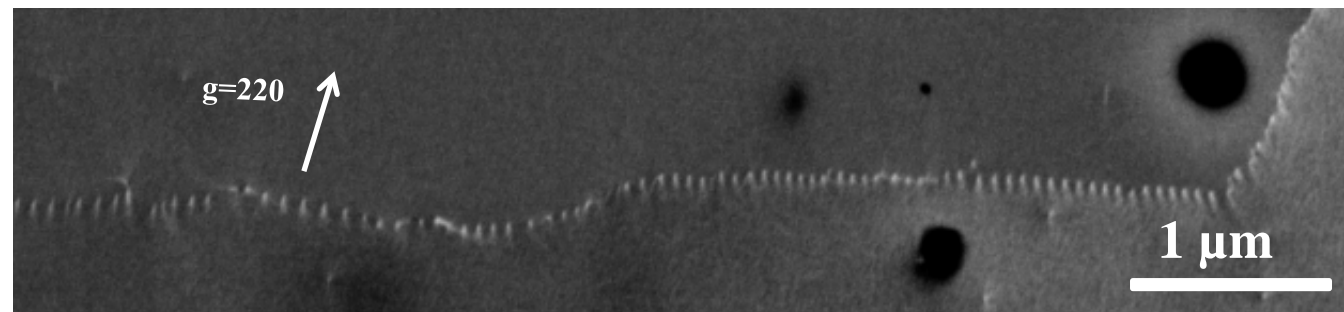
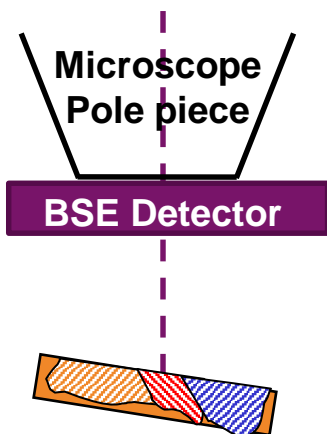

BSE image at high magnification in specific diffraction condition

Misorientation map

- ☹ The substructure is embedded in the **orientation noise**
- ☹ Voids are indexed with artificial misorientations with the neighborhood

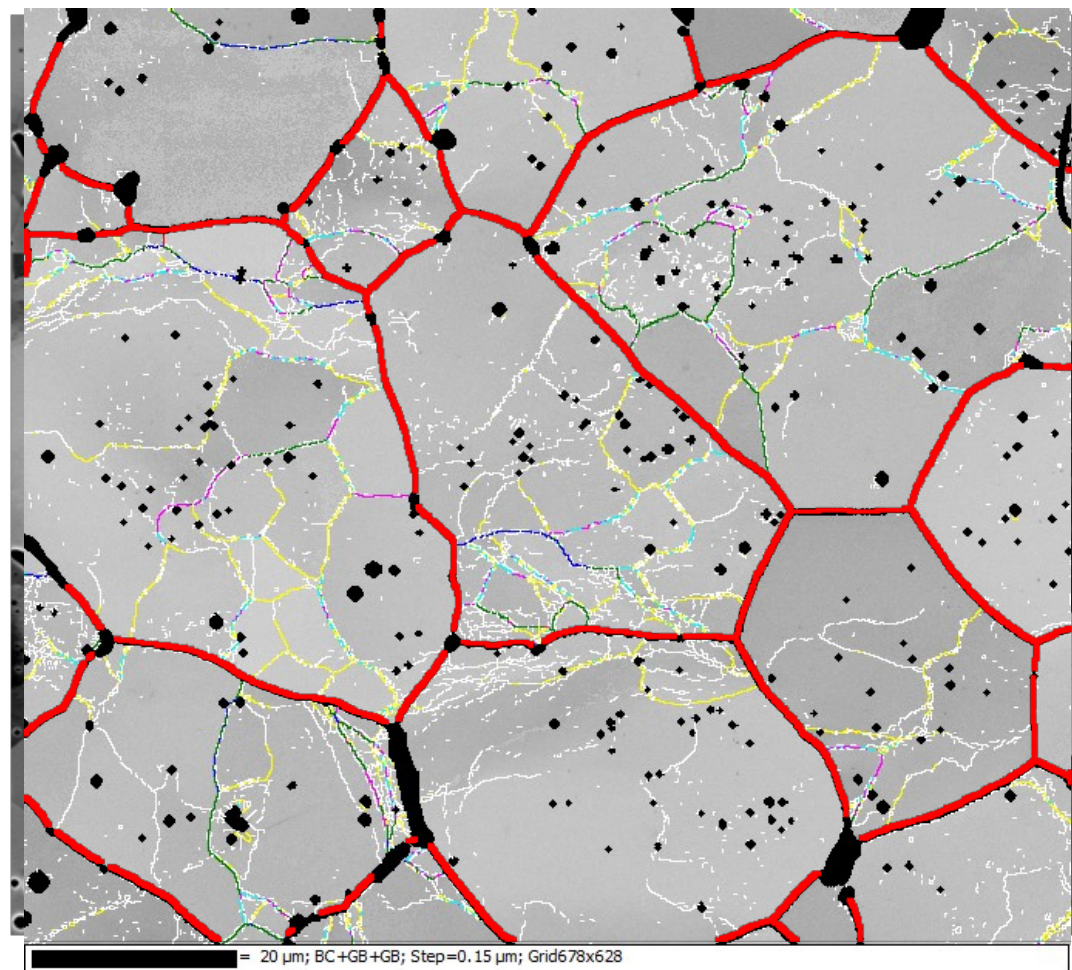

BSE micrograph of an UO₂ sample tested at 1500°C, under 50 MPa



Optimize data acquisition and processing



Best angular resolution on the EBSD map

Steps:

1) Acquisition:

- Camera setting: Binning ↘
- Indexing pattern: improved angular resolution mode in Aztec*

2) Data cleaning and filtering:

- Bande Slope index was used to identify pixels indexed over voids and set them to non indexed
- Kuwahara filter was applied to reduce the orientation noise**

*K. Thomsen , N.H. Schmidt , A.Bewick , K. Larsen and J. Goulden, Improving the Accuracy of Orientation Measurements using EBSD, Oxford note

** F.J. Humphreys, P.S. Bate, P.J. Hurley, Orientation averaging of electron backscattered diffraction data, J. Microsc. 201 (2001) 50–58

Misorientation map

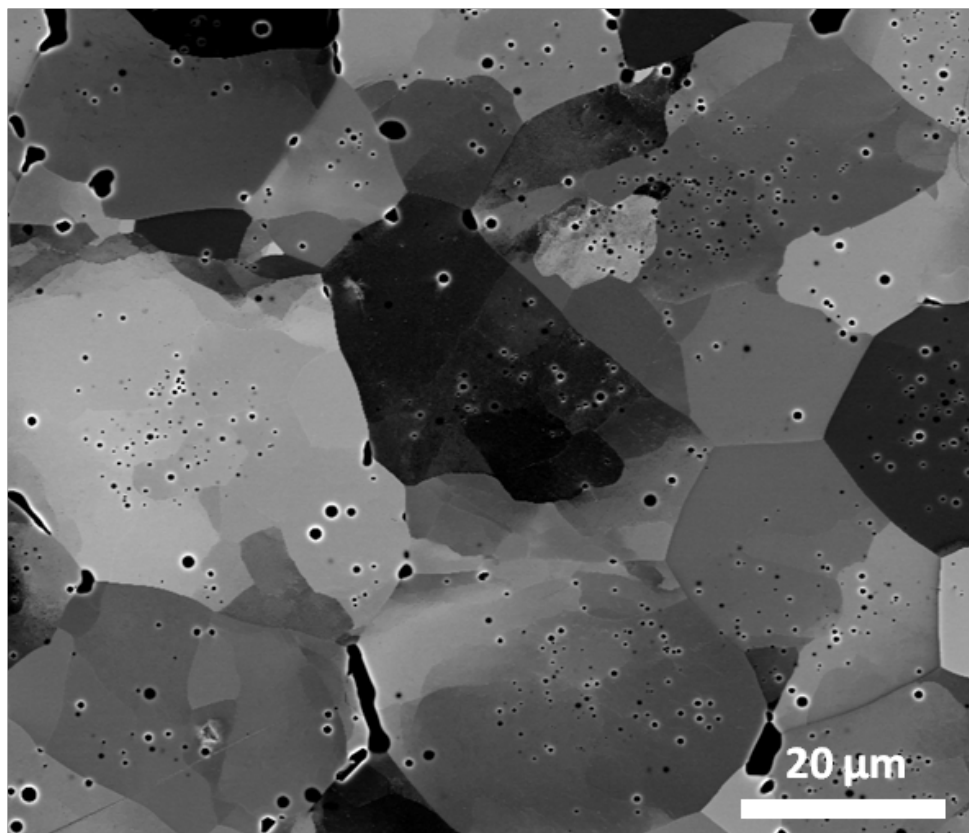

BSE micrograph of an UO_2 sample tested at 1500°C, under 50 MPa

The deformation induced a network of low angle boundaries

EBSD resolves low angle boundaries with misorientations down to 0.1° !

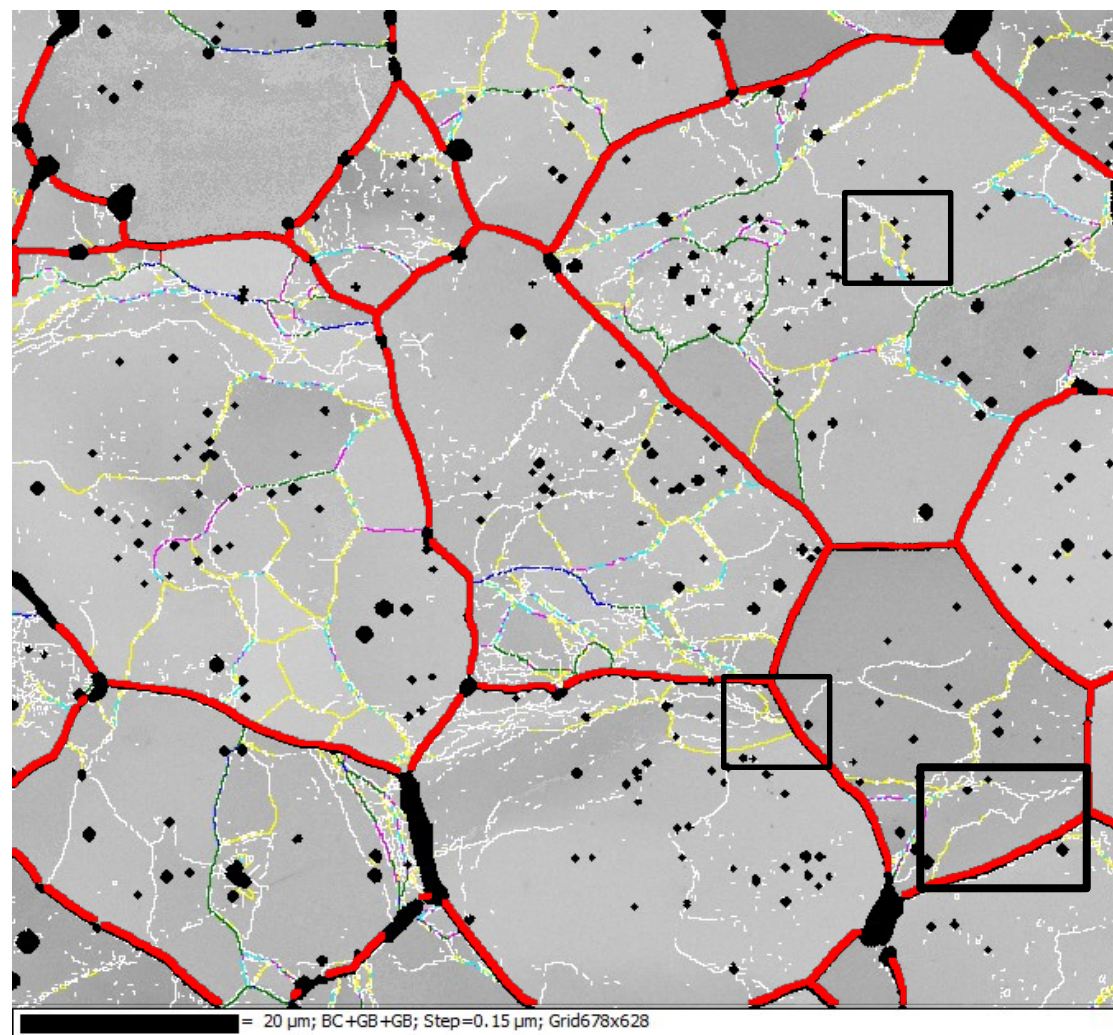

Misorientation angle Θ
Color code

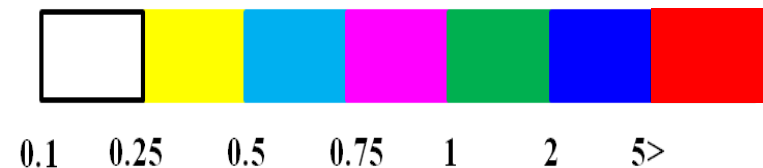

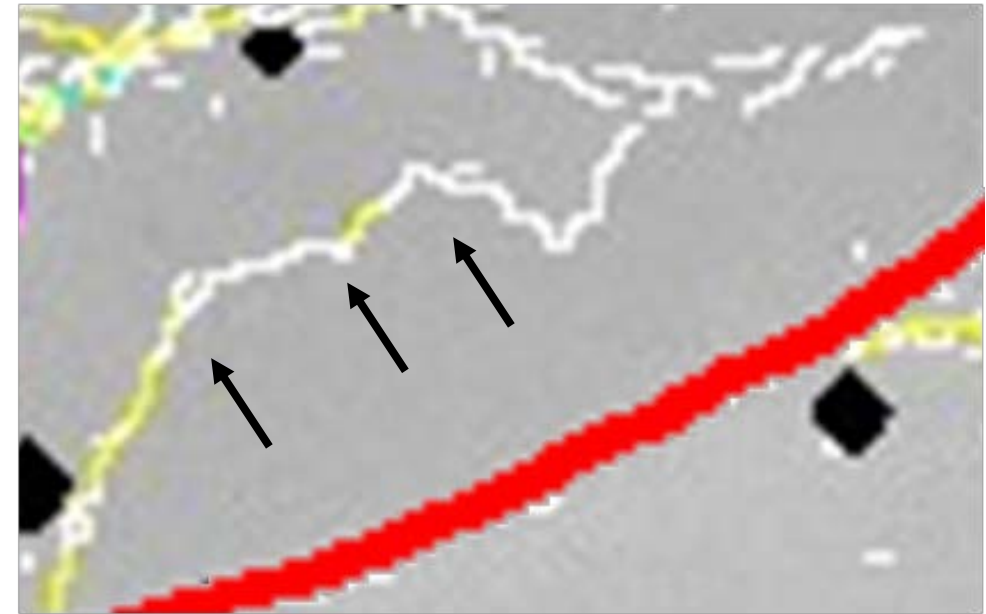
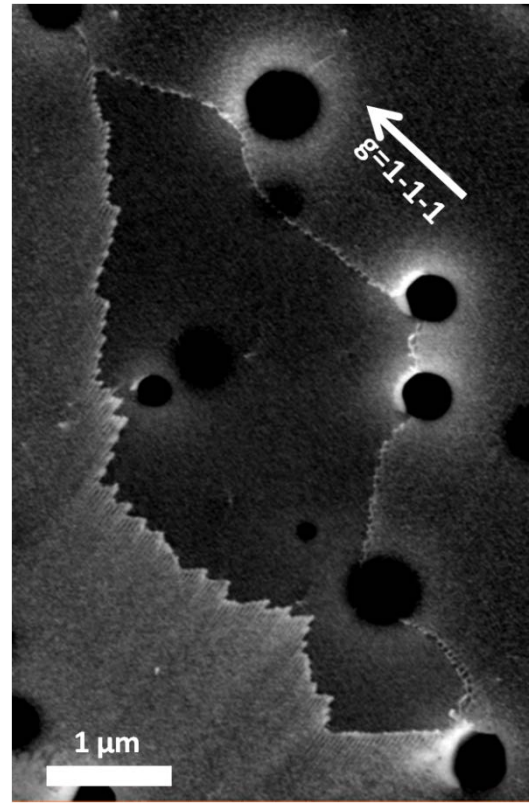
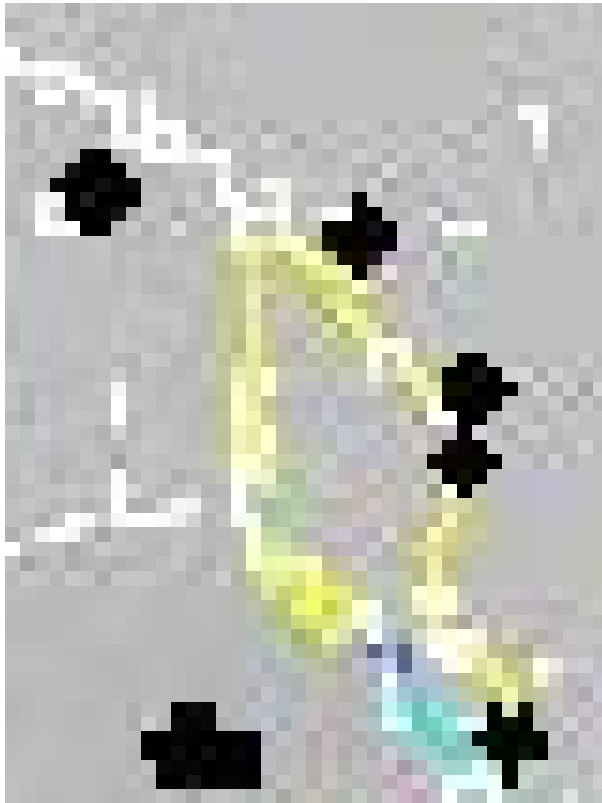

$\Delta\theta \in [0.1^\circ \text{ to } 0.5^\circ]$

$\Delta\theta \in [0.25^\circ \text{ to } 0.5^\circ]$

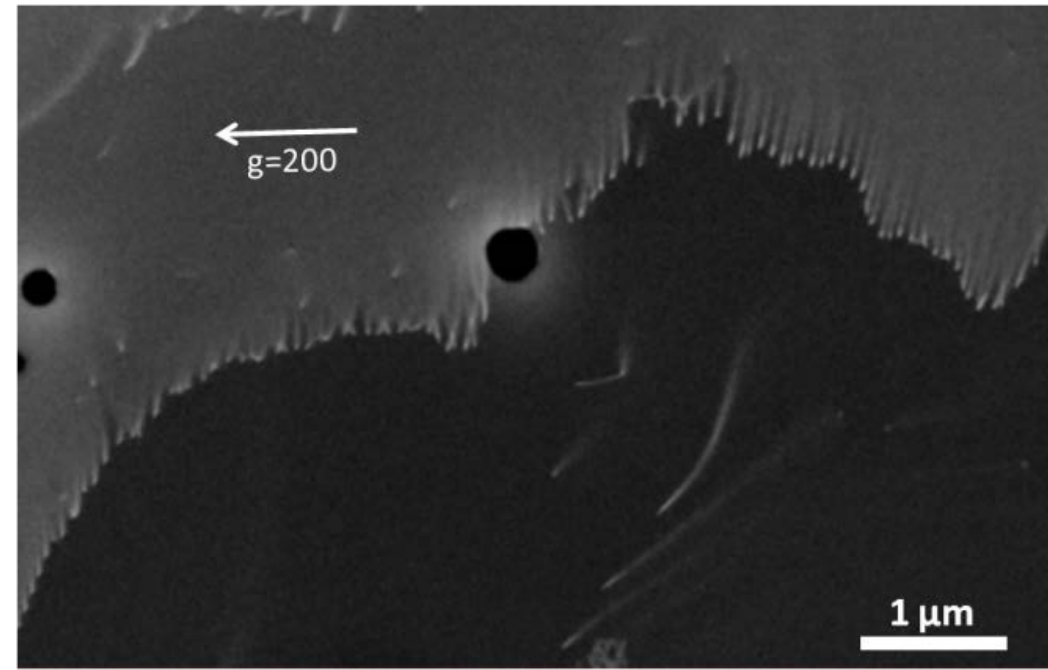

Misorientation angle θ
Color code

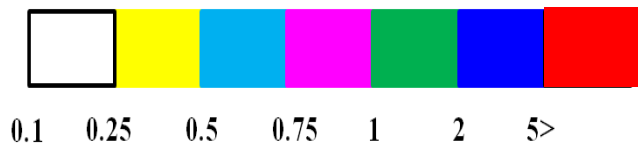

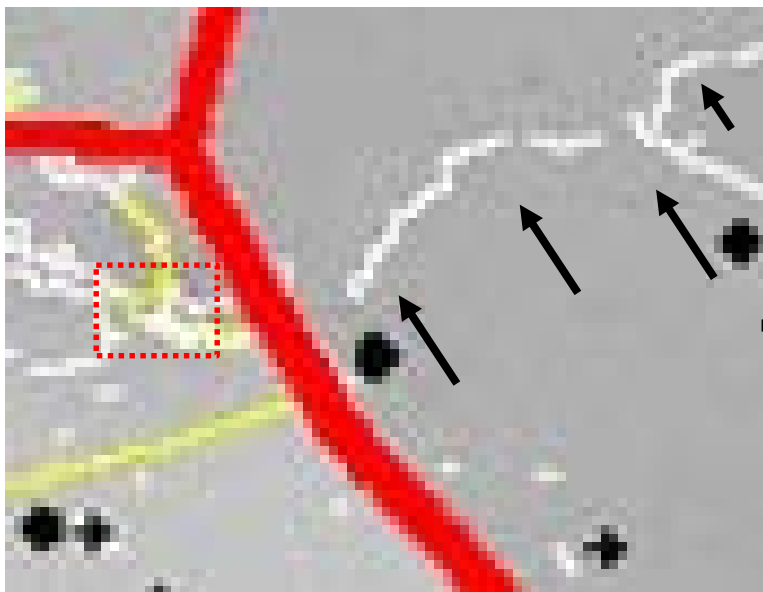

ECCI

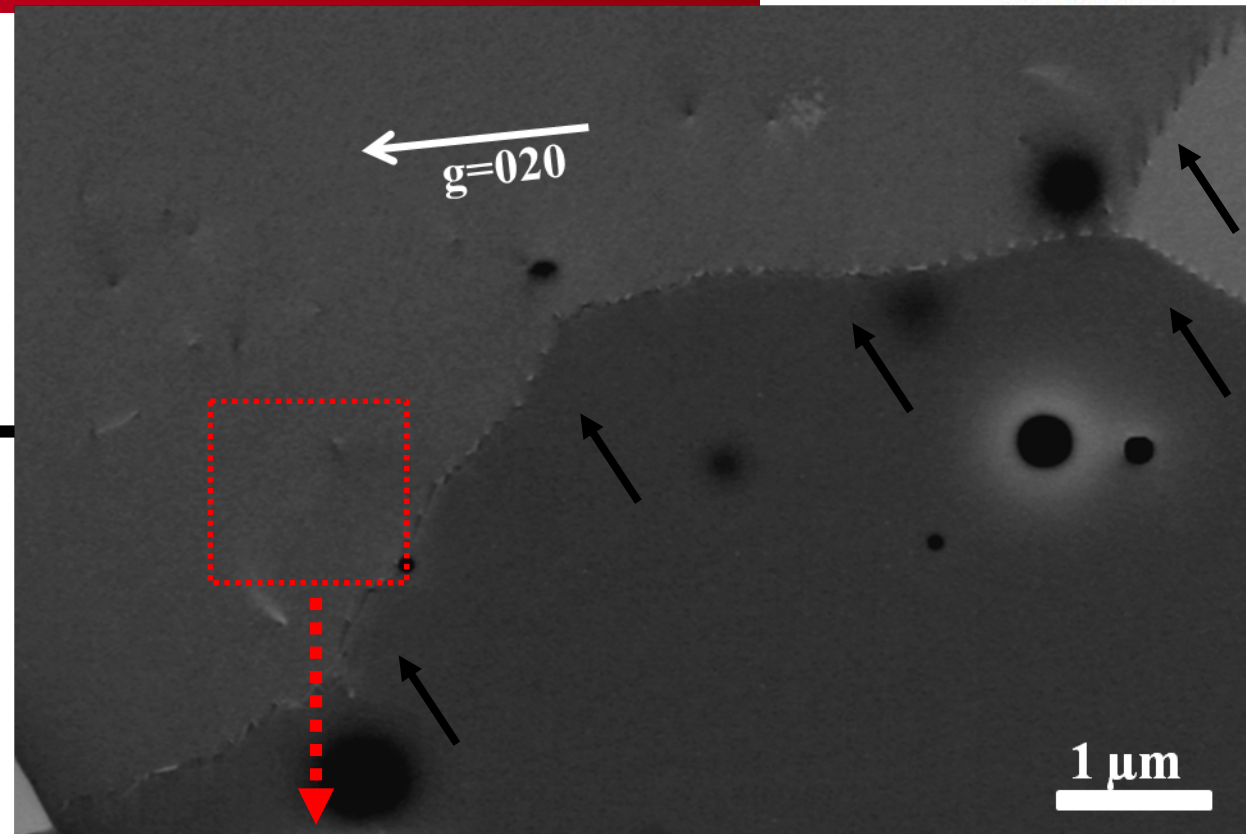

Previous TEM results

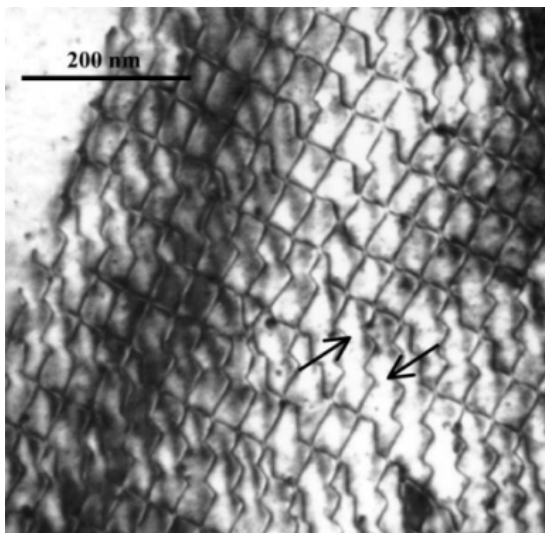

=

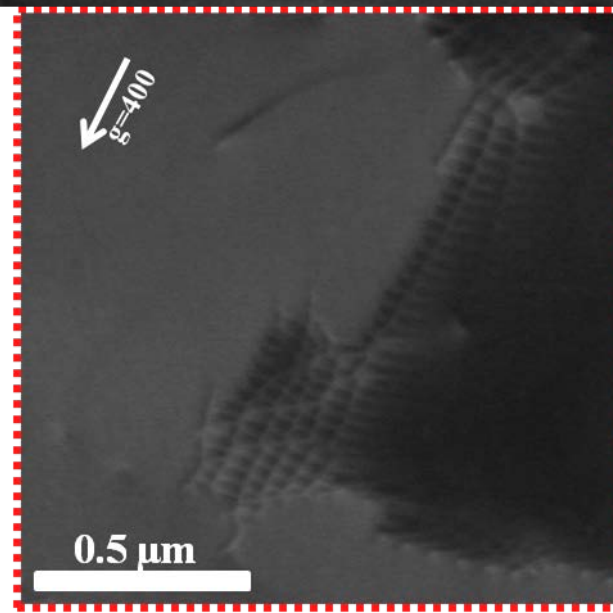

**Dislocations
Network**

F. Dherbey *et al.* 2002

The lattice curvature measured by EBSD can be used to evaluate the local density of GNDs :

From the disorientation between two neighboring points : $\Delta\theta_i$

separated spatially by Δx_j ,

the lattice curvature: $K_{ij} = \frac{\Delta\theta_i}{\Delta x_j}$

Dislocation density tensor [Nye]: $\alpha = \begin{bmatrix} ? & \alpha_{12} & \alpha_{13} \\ \alpha_{21} & ? & \alpha_{23} \\ ? & ? & \alpha_{33} \end{bmatrix}$

and the total GND's density: $\rho_{\text{total}} = \frac{\|\alpha_{ij}\|}{|b|}$

LEM3
Software



$b = a/2 \langle 110 \rangle$

This software is developed by [Benoît Beausir](#) and [Jean-Jacques Fundenberger](#)

EBSD: GND evaluation from lattice curvature

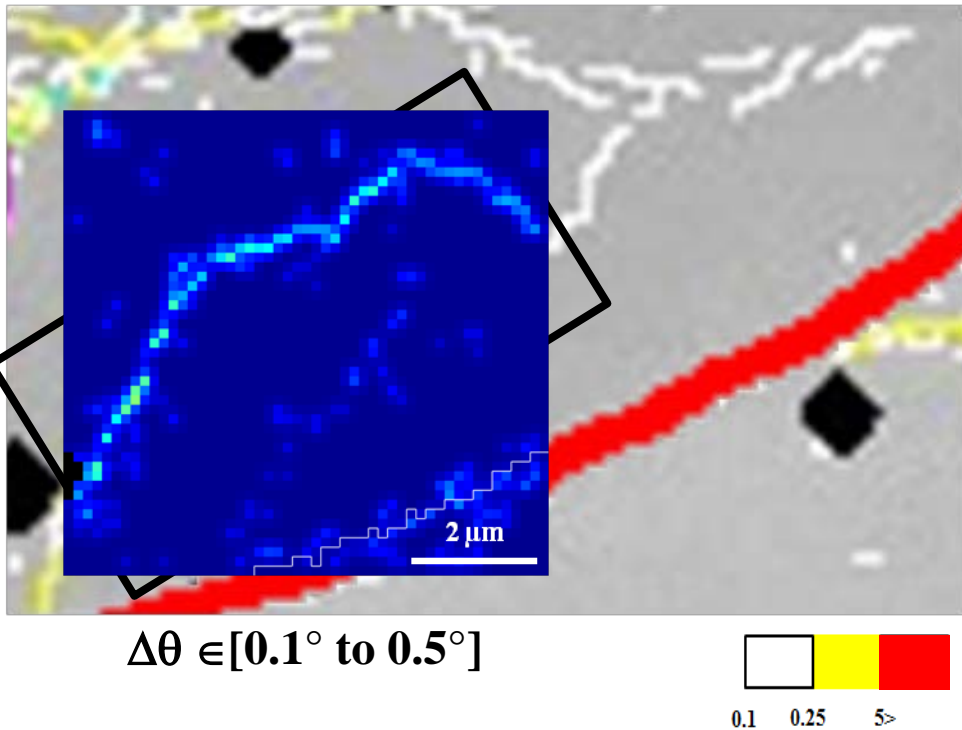

ECCI: Dislocations arrangement in low angle boundaries

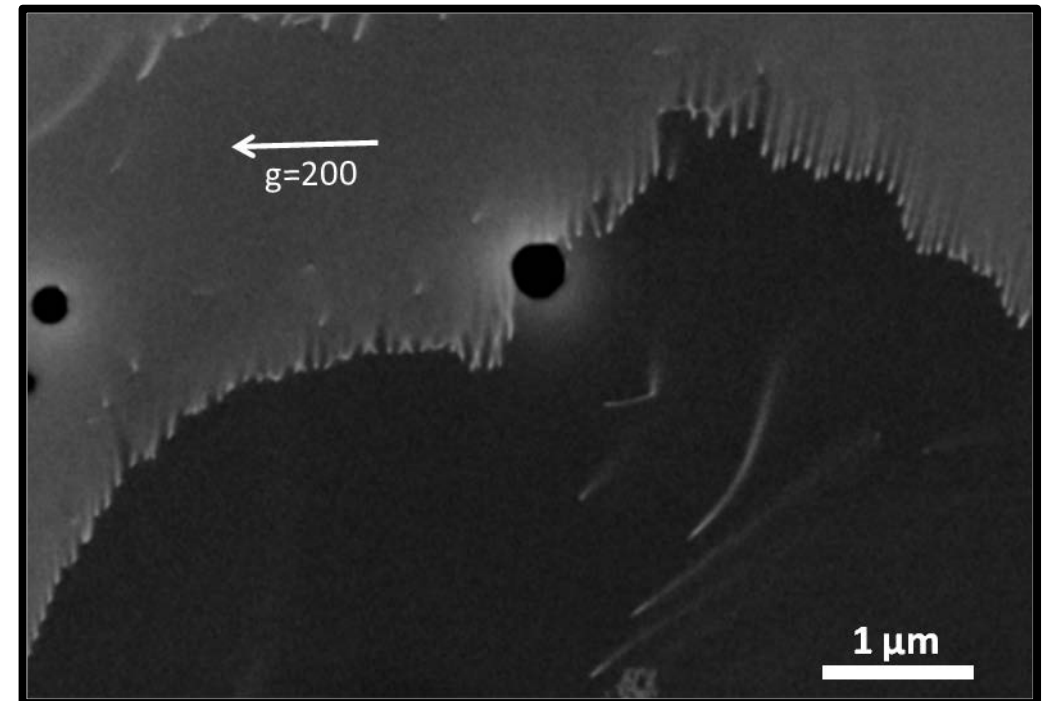

$$\rho_{\text{GNDs}}(\text{min/max}) = [1.47 - 12.3] \times 10^{13} \text{ m}^{-2}$$

$$\Delta x_j = 150 \text{ nm}$$

$$\rho_{\text{ECCI/average}} = 8 \times 10^{13} \text{ m}^{-2}$$

EBSD (GNDs filtering)

As sintered sample: not deformed

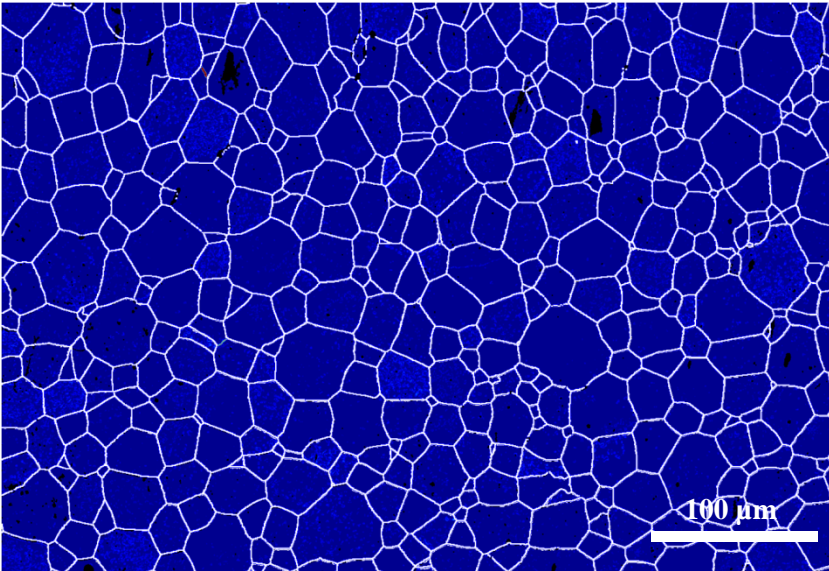

$$\rho_{\text{GNDs}} = 6 \times 10^{11} \text{ m}^{-2}$$

This represents the **spurious** GND density induced by the noise

10 time higher

Deformed sample at 8% in the dislocational creep regime

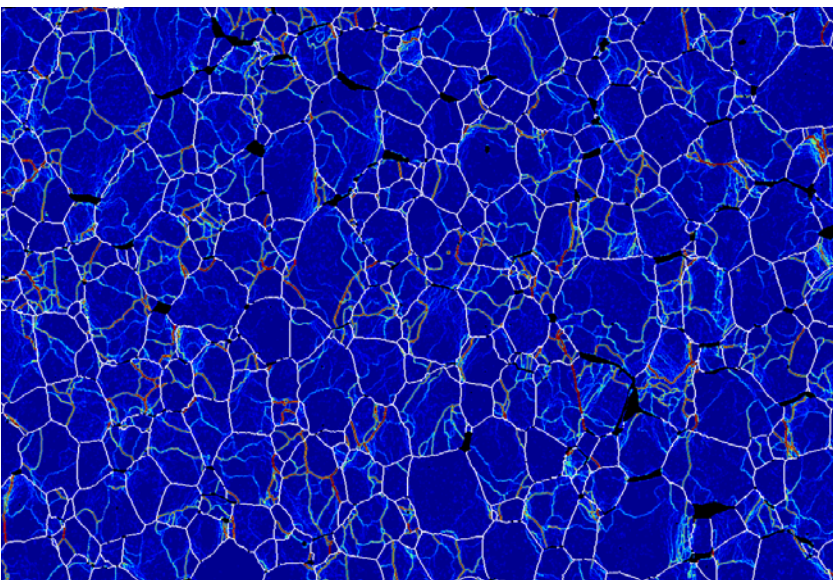

$$\rho_{\text{GNDs}} = 6.45 \times 10^{12} \text{ m}^{-2}$$

$\Delta x_j = 400 \text{ nm}$



- **EBSD: Quantification of low angle boundaries down to 0.1°,
Their evolution with the creep deformation,
Evaluation of the GNds**
- **ECCI: Imaging of the dislocations in the low angle boundaries
with a TEM quality image but in bulk material,
Analyse their arrangement in networks (**Hexagonal**, square...),
Deduce the dislocation density**

**On coming work, we applied EBSD/ECCI to quantify the evolution of
microstructures and sub-boundaries
for different creep conditions**

Thank you for your attention

