



HAL
open science

High temperature creep of uranium dioxide on the influence of equilibrium oxygen partial pressure

P. Garcia, A. Miard, J.B. Parise, M. Ben Saada, X. Iltis, C. Introni, T. Helfer

► **To cite this version:**

P. Garcia, A. Miard, J.B. Parise, M. Ben Saada, X. Iltis, et al.. High temperature creep of uranium dioxide on the influence of equilibrium oxygen partial pressure. MRS spring meeting 2018, Phoenix, Apr 2018, Phoenix, United States. cea-02338950

HAL Id: cea-02338950

<https://cea.hal.science/cea-02338950v1>

Submitted on 14 Dec 2019

HAL is a multi-disciplinary open access archive for the deposit and dissemination of scientific research documents, whether they are published or not. The documents may come from teaching and research institutions in France or abroad, or from public or private research centers.

L'archive ouverte pluridisciplinaire **HAL**, est destinée au dépôt et à la diffusion de documents scientifiques de niveau recherche, publiés ou non, émanant des établissements d'enseignement et de recherche français ou étrangers, des laboratoires publics ou privés.

DE LA RECHERCHE À L'INDUSTRIE

cea



INSPIRE

www.cea.fr

High temperature creep of uranium dioxide: on the influence of equilibrium oxygen partial pressure

P. Garcia, A. Miard, J.-B. Parise, M. Ben Saada, X. Iltis, C. Introni, T. Helfer

CEA Cadarache, DEN, DEC

MRS Spring meeting - Phoenix | 4 April 2018

- 1. Context of study
- 2. From creep testing to understanding microstructural effects
- 3. Experimental details
- 4. Modelling and interpretation
 - 1 vs. 2D modelling
 - Microstructural changes
- 5. Conclusion and prospects

1.1 An essential modelling ingredient for fuel performance applications

- Pellet and cladding subject to range of TM effects^[1]
- Differential thermal expansion
 - pellet cracking \Rightarrow hourglass
 - Radiation induced Creep

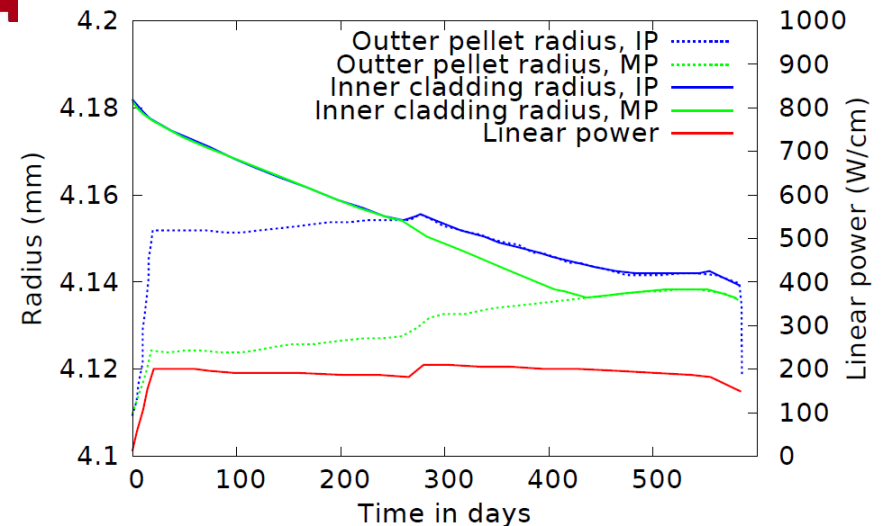
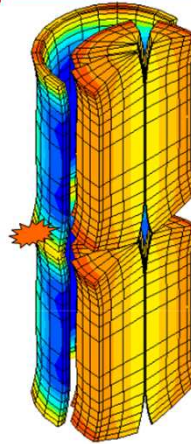

Kinetics of formation of primary ridges & TM state of cladding are determined by radiation induced creep

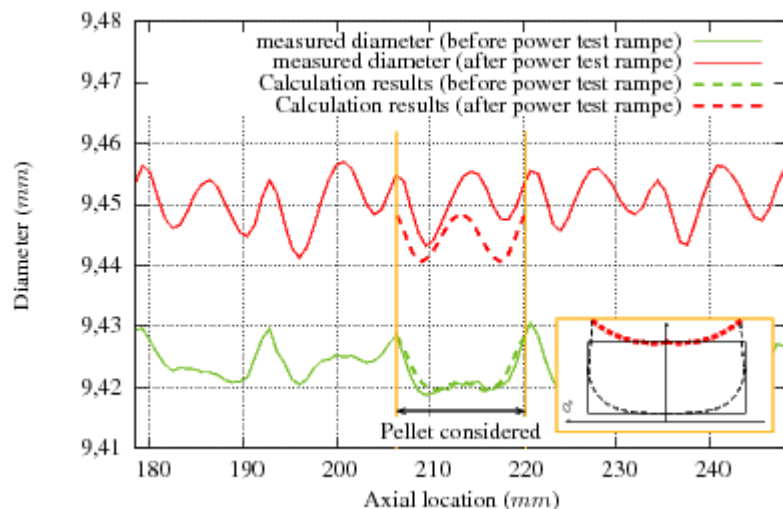

During power ramps, cladding stresses and strains controlled by thermal creep of pellet and cladding

[1] Helfer, Castelier, Garcia, Euromech 2005, Eindhoven

1.2 Material's property approach

Quantify, understand and model the influence of microstructure upon oxide fuel properties^[1,2]

- Redox activity, dopants or additives, grain size, porosity, irradiation...

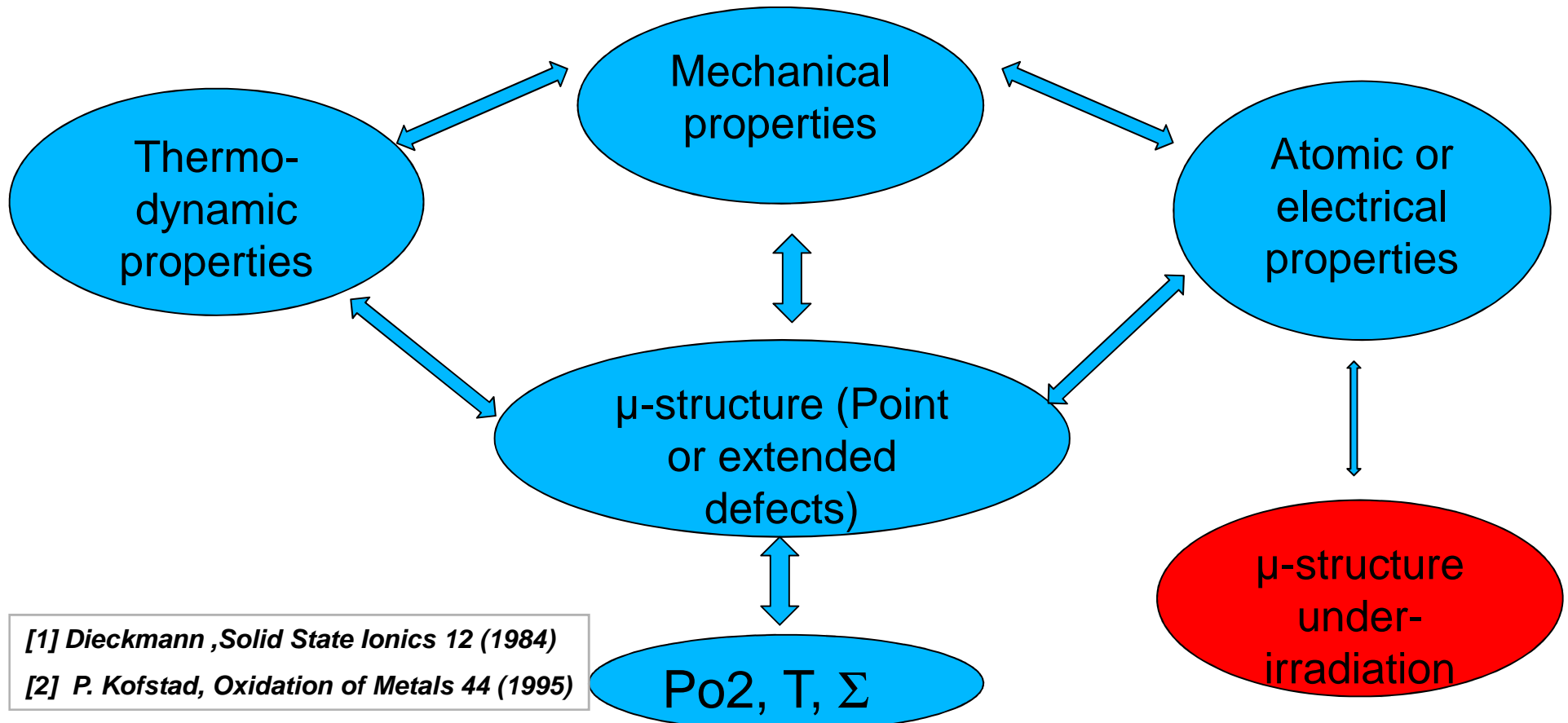

2.1 From macroscopic creep tests to mechanisms...

- Macroscopic compression/bending tests: constant load or strain rate

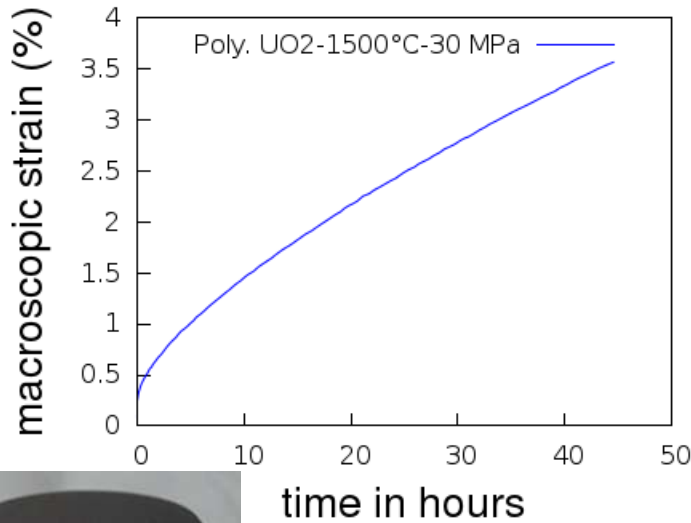

time in hours
 $\sim 10^{-7} \text{ s}^{-1}$

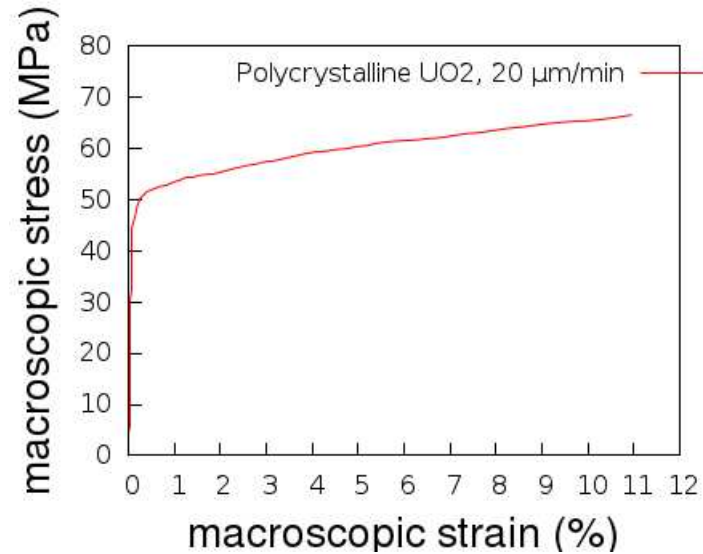

$2 \times 10^{-5} \text{ s}^{-1}$



- Fuel behaviour applications:

$$\dot{\epsilon} \sim K \times \sigma^n \times d^p \times \text{Exp}\left(-\frac{E}{kT}\right)$$

How well do these laws reproduce the behaviour of UO_2 ?
What do the coefficients actually represent?

2.2 Effect of stress and grain size in “nominally stoichiometric material”

$$\dot{\epsilon} \sim K \times \sigma^n \times d^p \times \text{Exp}\left(-\frac{E}{kT}\right)$$

- High $\sigma \Rightarrow$ high n values ($4.5^{[1,2]}$):
 - dislocation sources: glide and climb
 - dislocation movement inhibited by GB (hardening, $p \sim -2$)^[3]
- Low $\sigma \Rightarrow$ low n ($1^{[1,4]}$):
 - Diffusion of defects due to chemical potential gradient
 - strain rate inversely proportional to grain size ($p \sim -2$), volume diffusion control^[2]
- Transition at σ level dependent upon grain size

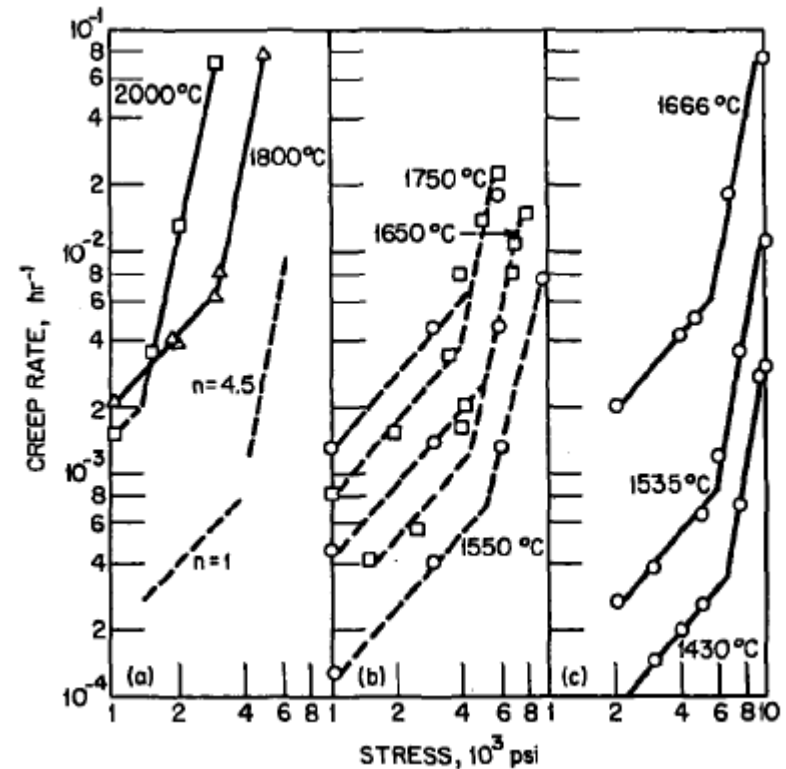

What physical meaning can be given to the activation energy?

[1] M.S. Seltzer, JNM 34 (1970)

[2] Weertman JAP 26, XXXX

[3] C. Duguay, PhD, INSA Lyon (1998)

[4] C. Herring JAP 21, XXXX

2.3 Relationship between cation diffusion and creep?

- In pure metals, E is the self-diffusion activation energy (Weertman & Herring)
- Creep properties in binary or ternary oxides^[1]?
- At low stress:
 - Diffusional controlled deformation process and kinetics
 - $\propto D$ of slowest moving element, migrates with least abundant defect population^[2] (cation)
- At high stress:
 - Temperature activated glide & Dislocation climb (kinetics)
 - In UO_2 combination of both (recovery-creep)^[2,3,4]
 - $\propto D$ of slowest moving species

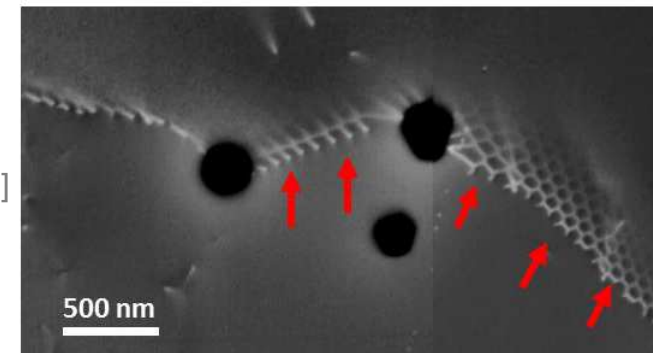
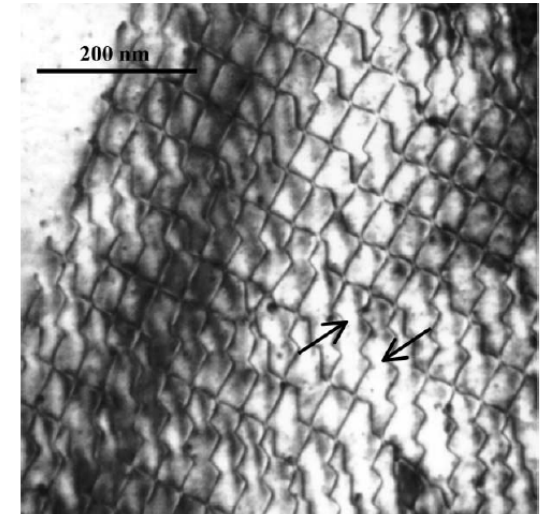

Ecci image: sub-grain boundary^[5]

$$\dot{\epsilon} \sim K \times \sigma^n \times d^p \times D_U$$

[1] J. Philibert *ssi.* 12 (1984)

[2] Garcia et al. *JNM* 494, 2017

[3] Dherbey et al. *Acta Mater.* 50 (2002)

[4] Alamo et al.

[5] Ben Saada PhD, Metz 2017 (Gey, Maloufi, Iltis)

2.4 Effect of non-stoichiometry and oxygen pressure

- If creep is self-diffusion controlled \Rightarrow strong dependence upon deviation from stoichiometry^[1]
- More appropriate to interpret data $f(p_{O_2})$
 - p_{O_2} is the true thermodynamic property^[2,3,4]
 - Practical reasons: $\Delta x \sim 2 \cdot 10^{-3}$, Δp_{O_2} : 4 orders of magnitude
 - Measured parameters are physically meaningful^[2]
- One can expect the following

$$\dot{\epsilon} \sim K \times \sigma^n \times d^p \times f_U[V_U] D_{VU}$$

$$\dot{\epsilon} \sim K \times \sigma^n \times d^p \times f_U p_{O_2}^\alpha \exp\left(-\frac{E_f}{kT}\right) \times D_{VU}^0 \exp\left(-\frac{E_m}{kT}\right)$$

α and $E_f \Rightarrow$ characteristic of defect formation, E_m and $D_{VU}^0 \Rightarrow$ characteristic of defect migration

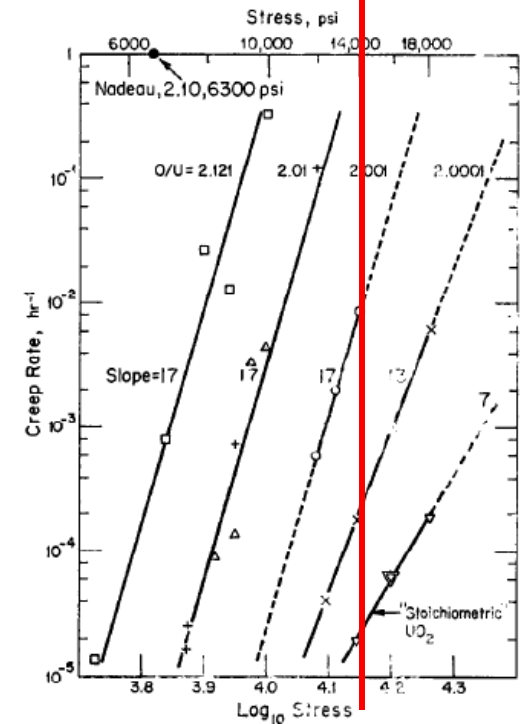

Fig. 2. Creep rate as a function of applied stress for UO_{2+x} single crystals tested in compression at 1100 °C. The compression data of Nadeau²⁰⁾ for slip is included.

[1] Seltzer et al. J. Nucl. Mater (1972)

[3] Dorado et al. PRB 83, 2011

[2] J. Philibert ssi. 12 (1984)

[4] Dorado et al. PRB 86, 2012

3.1 Creep tests under controlled atmosphere

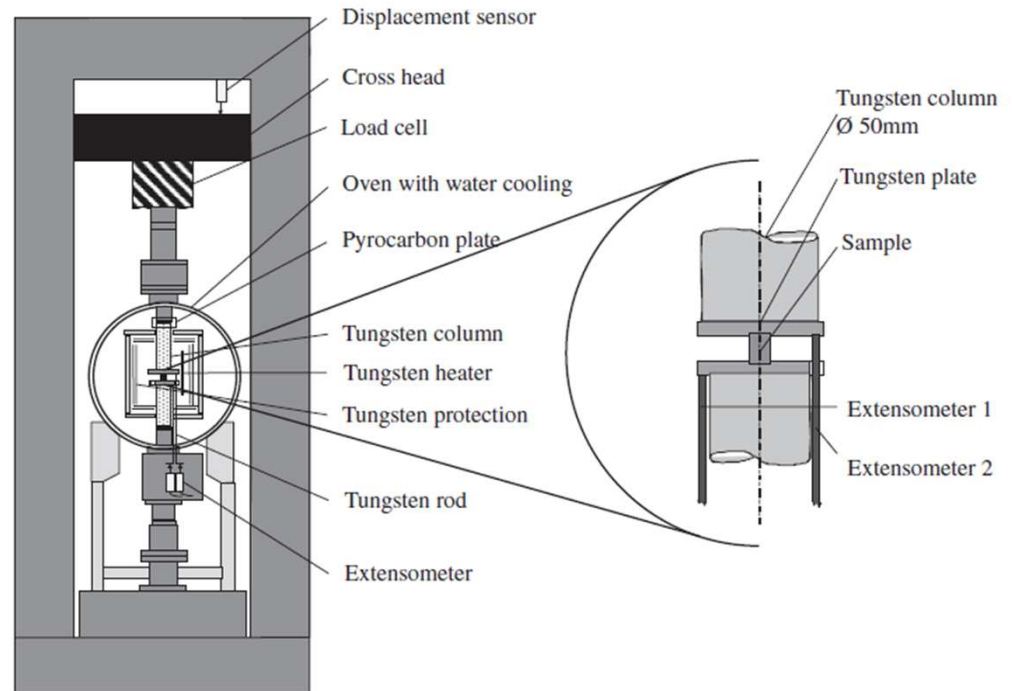

- Compression testing
 - 100 kN frame equipped with W ~1700°C furnace & – *in situ* extensometers
 - Originally all tests carried out under Ar/H₂
 - Roughly 50 l of “free volume”
- System equipped with oxygen and humidity probes, upstream and downstream

3.2 Atmosphere control

- Control based on buffering gas phase

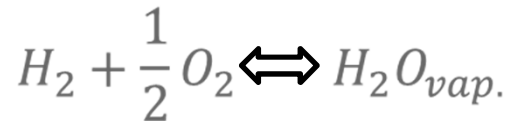

- Ar/H₂ carrier gas + humidification with YSZ oxygen pump
- Calculated values (know from Faraday's law [1]) ($n_{O_2} \propto i$)

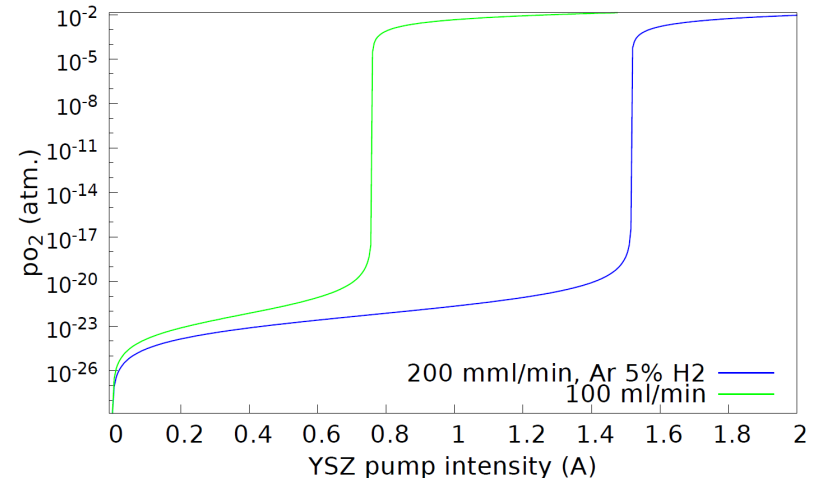

- Excellent agreement bet. th. and exp.
- Actual equilibrium of input and output \Leftrightarrow 12 hours
- Restricted range of accessible pressures
- Lower bound: determined by necessity for buffering to function
- Upper bound: furnace oxidation

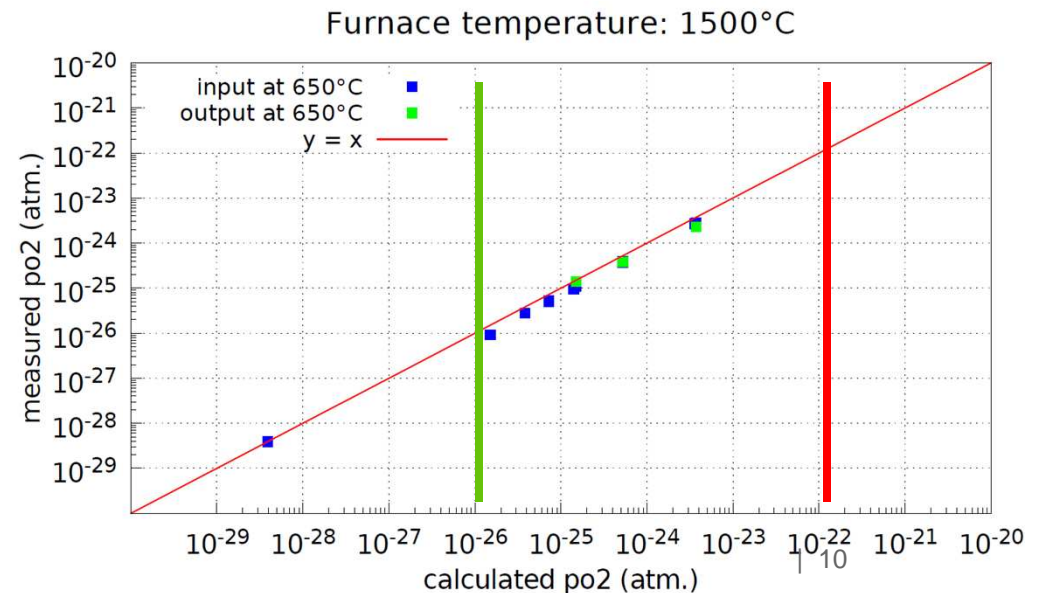

cea 3.4 Materials used and tests run

- All tests run at 1500°C on polycrystalline samples
- 16.1 mm +/-0.2 mm height, 8.190 mm diameter +/-0.010 mm ⇒ limiting 2D effects
- Grain size ~ 14 μm – pore fraction 1.8 +/-0.1 % (high density)
- Final strain between 13 and 14%

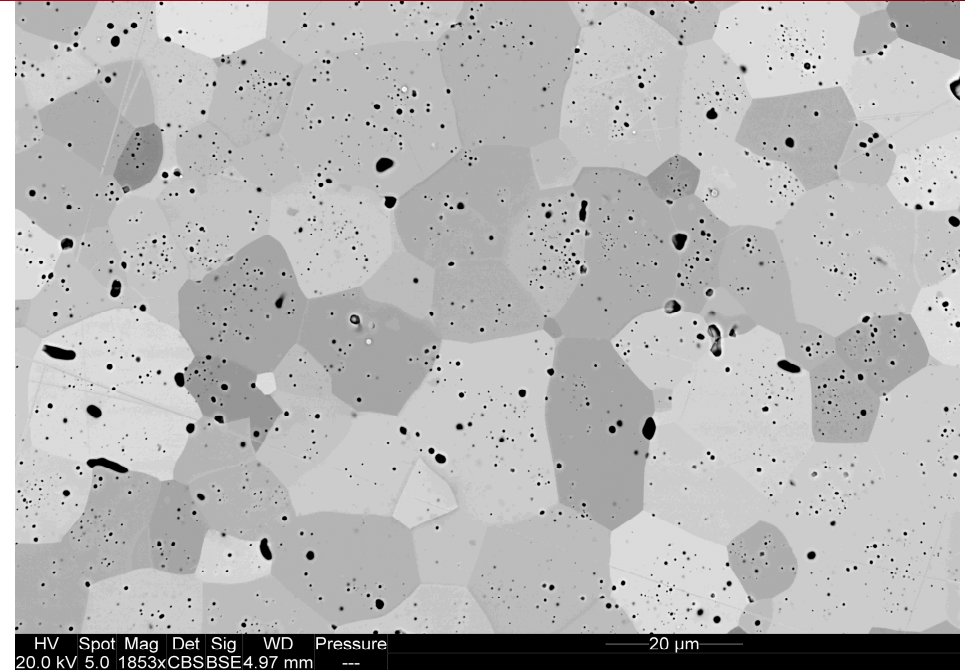

Test number	Crosshead speed (μm/min.)	Approximate linear strain rate (s ⁻¹)	Oxygen pressure (atm.)	Duration (mins)
1	20	2×10^{-5}	1.3×10^{-12}	126
2	20	2×10^{-5}	1.1×10^{-11}	123
3	20	2×10^{-5}	1.3×10^{-11}	129
4	20	2×10^{-5}	4.8×10^{-11}	127
5	20	2×10^{-5}	7.3×10^{-11}	130

4.1 Macroscopic experimental data available and preliminary analysis

- Experimental data available:
 - *In situ* pellet height $h(t)$, load $F(t)$
 - Post-test profile, height and density

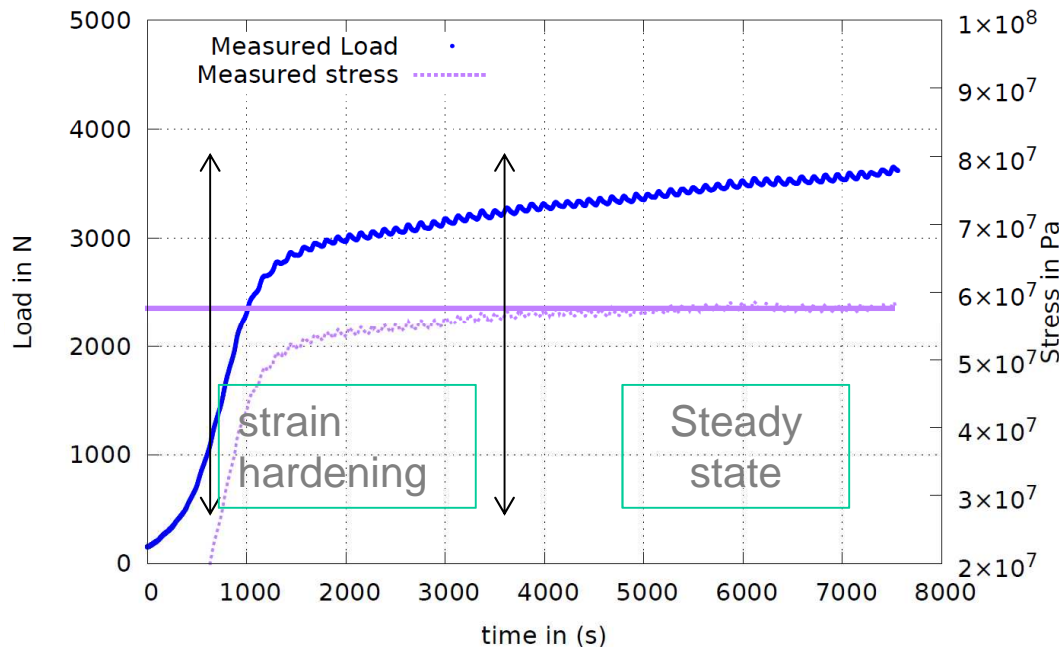

- **Linear** crosshead displacement
- Initial phase: **combined response** of setup and pellet
- Fluctuations in measured load values
- Small fluctuations in displacements measured by extens.

- Uniaxial hypothesis & constant V process $\Rightarrow \sigma_{eq}(t) \approx \sigma_z(t) \approx \frac{F(t)}{S(t)} \approx \frac{F(t)h(t)}{h_0 S_0}$
- Primary & secondary creep (Norton)

Uniaxial temptation is great
macroscopic hardening \Leftrightarrow primary creep & increase in section

4.2 How uniaxial are tests carried out at constant crosshead speed?

- Barrel-shaped pellet \Rightarrow friction with tungsten plates
- Salvo *et al.* have suggested pellet is clamped^[1]...

- 1 and 2D (axisymmetric) model using “mfront”^[2]:
behaviour law integrator
 - “mtest” in 1D^[3] environment
 - “licos@Cast3M”^[3,4]
 - Chaboche-type Kinematic hardening law \Rightarrow primary creep^[5]

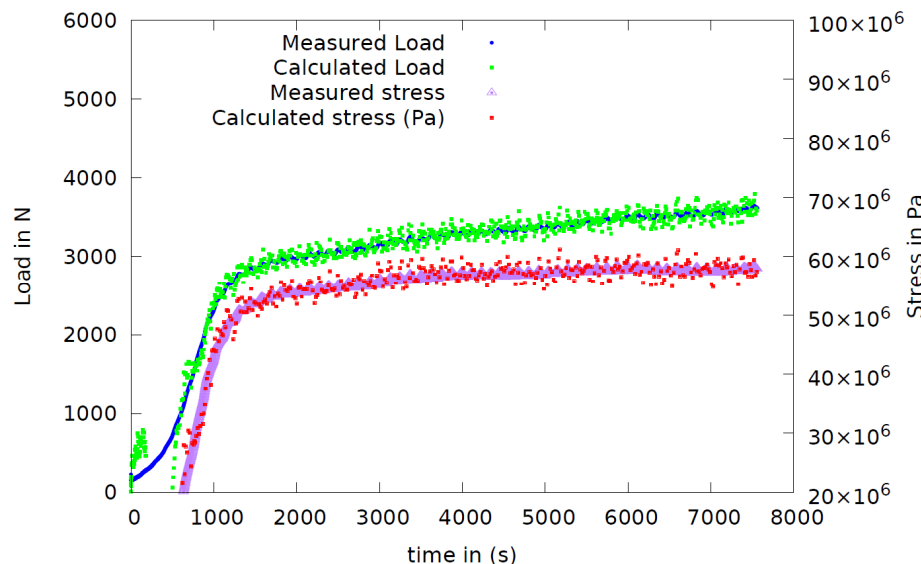

$$\dot{\epsilon}_{vp} = \left(\frac{|\underline{\sigma} - \underline{X}|}{K} \right)^n$$



- 1D Model reproduces data
- Even fluctuations (contained in displacement load) are reproduced
- Correlated parameters

\Rightarrow Confirms uniaxiality

[1] Salvo *et al.* JNM 456 2015

[2] Helfer *et al.* Computers & mathematics with applications 70 (2015)

[3] Helfer *et al.*, J. Nuc. Eng & Des. 294 (2015)

[4] <http://www-cast3m.cea.fr/>

[5] Colin, Thèse Ecole des Mines, 2006

4.3 Comparison of 1 and 2 D approaches

- 1D determination of model param.
- 2D: identical parameters and load
 - assuming no friction
 - assuming infinite friction
- Only **slight change in parameters** required
- 2D model reproduces profile ~
- **Uniaxial approach justified**

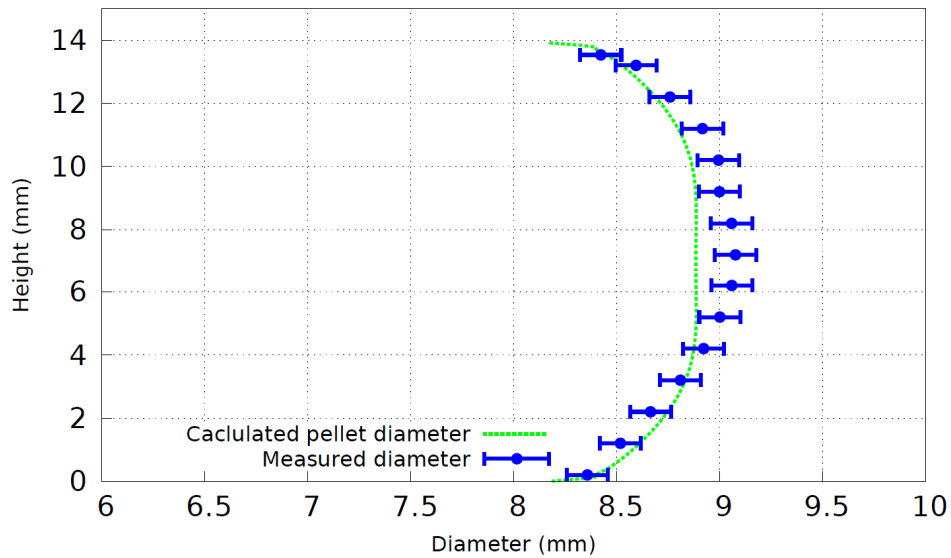
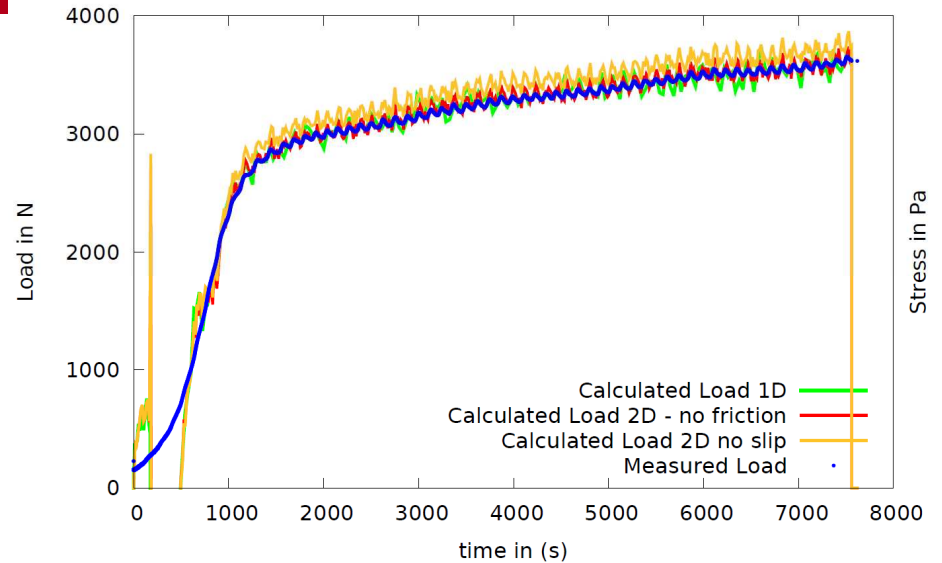

- 1D Model reproduces data
- Even fluctuations (contained in displacement load) are reproduced
- Correlated parameters

4.4 Result of 1D analysis

- If $X \ll \sigma$, analysis is straightforward and
- Plotting $\text{Log}(\sigma) = f(\text{Log}(p_{o_2})) \Rightarrow -\alpha/n$

$$\dot{\epsilon} \propto K p_{o_2}^{\alpha} \sigma^n$$

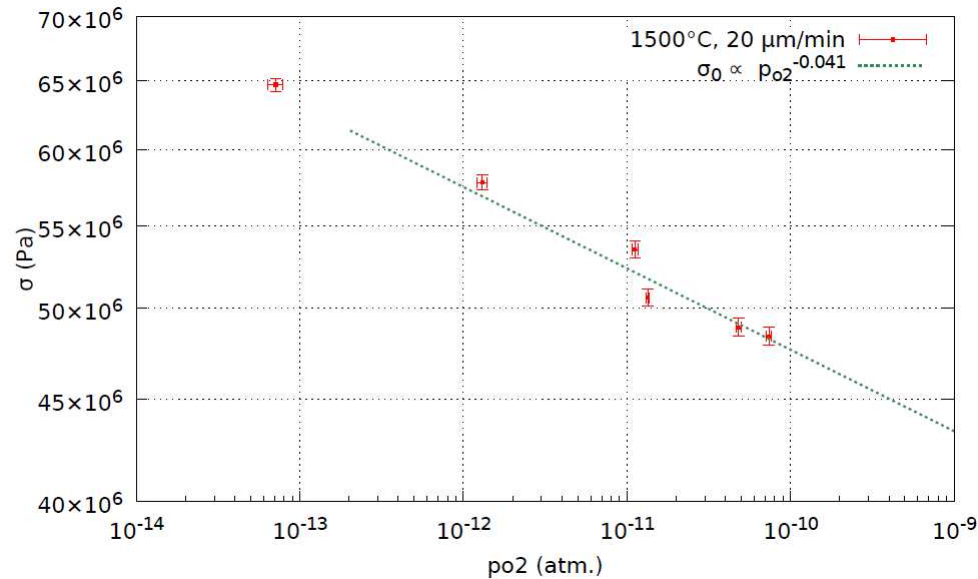

- Data points lie in ~ **straight line**
- $-\alpha/n \sim -0.041 \Rightarrow$ if $n \sim 4$, $\alpha \sim 1/6$
- Decreasing $f(p_{o_2}) \Rightarrow$ consistent with $\alpha > 0$ and **increasing $[Vu] \sim p_{o_2}^{1/6}$**
- n **can be identified** by changing conditions

■ Stress and strain inhomogeneity within the pellet

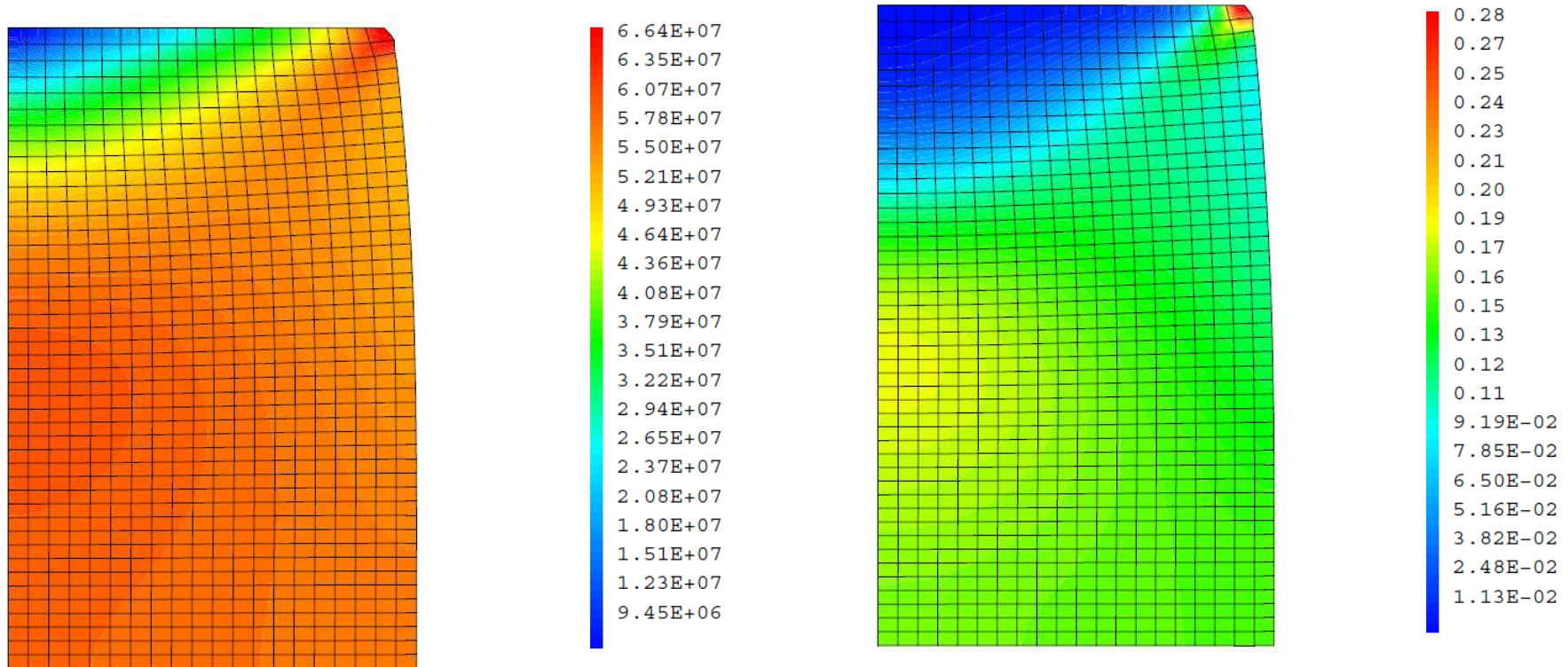

- Can one qualitatively correlate calculations to observable local microstructural changes?
 - Material reacts through process of grain fragmentation^[1]
 - Formation of cavities (void swelling) at high deformation values^[2]

cea 4.6 Preliminary characterization results

- P1, P2, P3 ($5 \cdot 10^{-26}$, $5 \cdot 10^{-25}$, $2 \cdot 10^{-24}$): **identical macroscopic** strain
- P1: Damage localization
- Formation of pockets of voids, located “away from” the plane of symmetry
- With increasing p_{o2}
 - **Volume fraction of pockets increases**
 - Associated grain **misorientation increases**

4.7 P1: lowest po2 (site 1)

- EBSD characterisation
- Fragmentation of grains into regions with small misorientations (between 0.25° and 3°)
- Linear fraction of small angle boundaries $>$ than in pellet tested under Ar/H₂

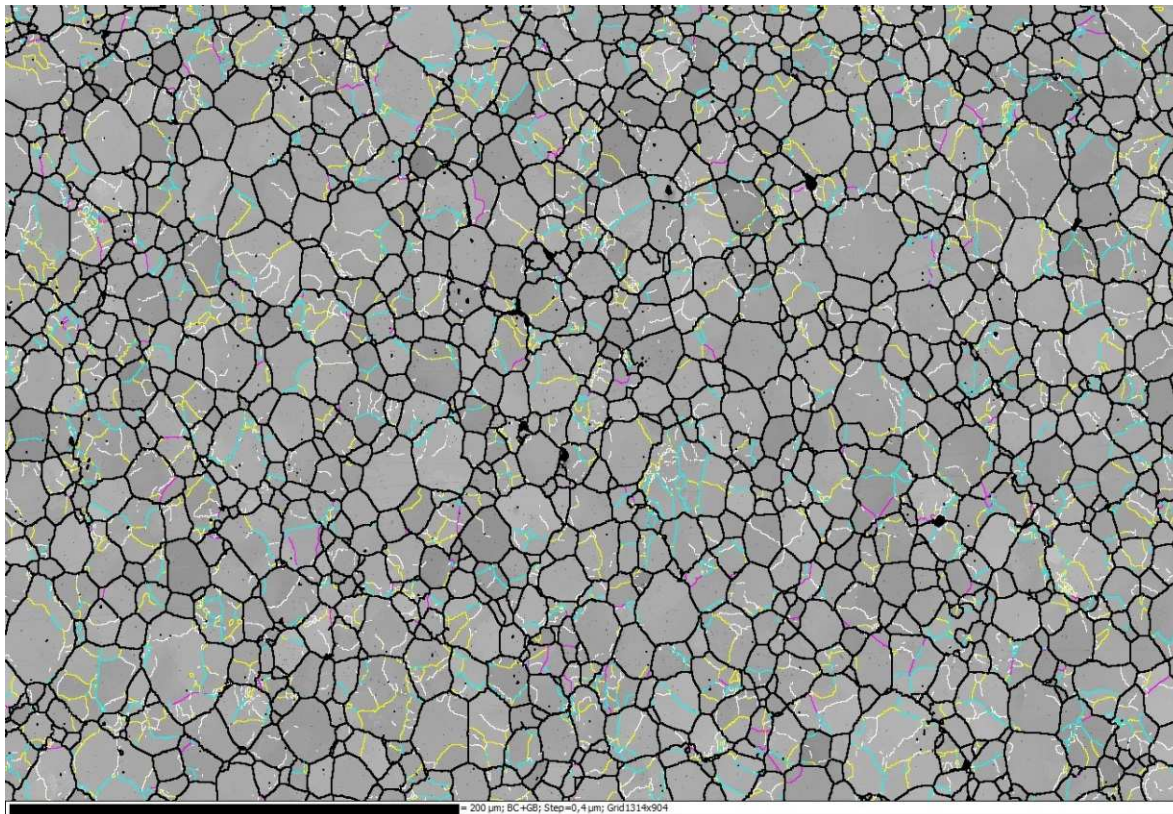
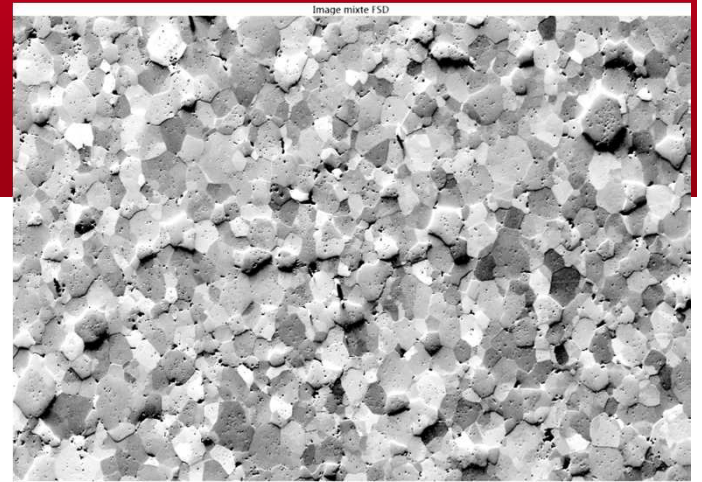

White: 0.25° / Yellow: 0.5° / Aqua : 1° / Pink: 3° / Black: 5° (non indexed pixels)

4.8 P1: lowest po2 (site 2)

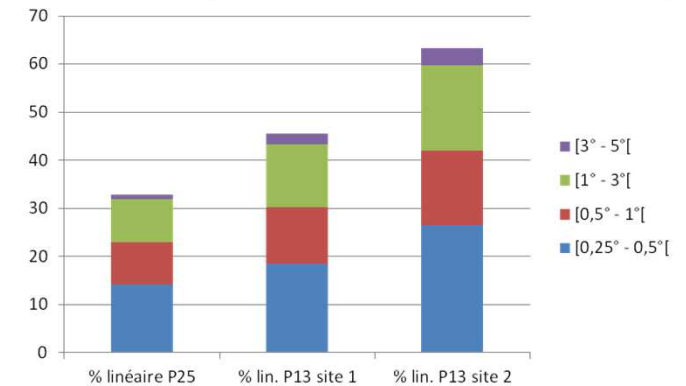
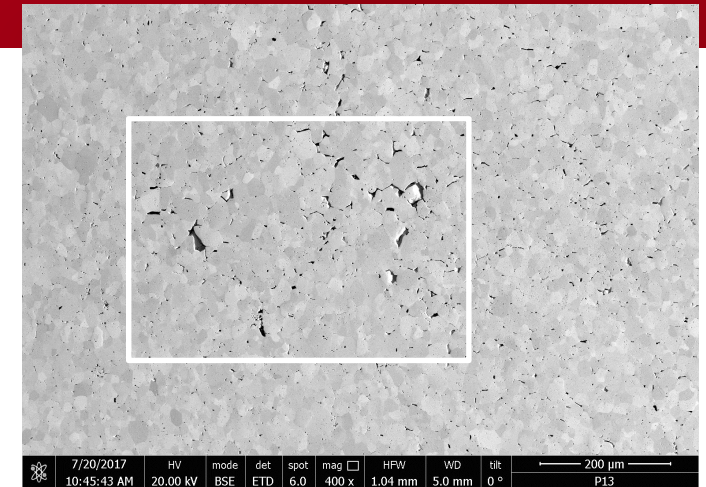
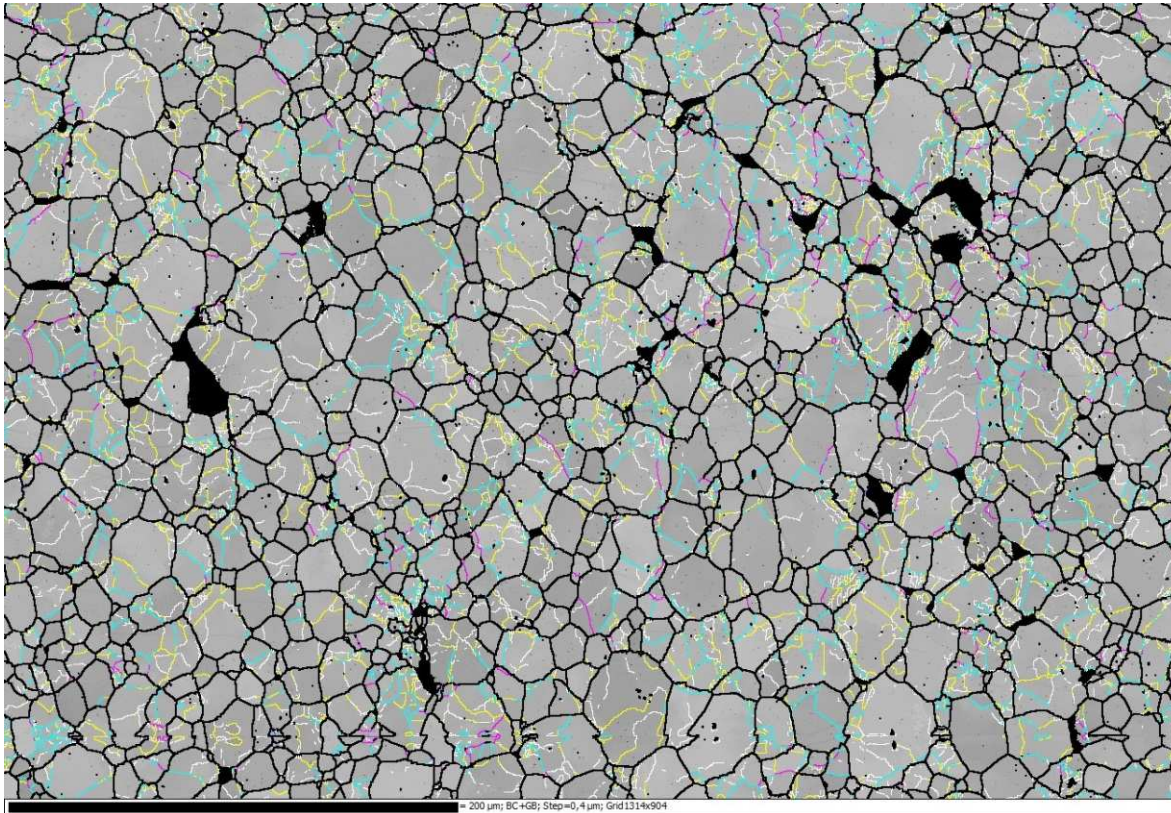

White: 0.25° / Yellow: 0.5° / Aqua : 1° / Pink: 3° / Black: 5° (non indexed pixels)

- Void fraction increase related
 - to damage/strain localisation
 - Increasing incompatibility between grains of different orientations
- Confirms **macroscopic heterogeneity**

4.9 P3: highest po2 (site 2)

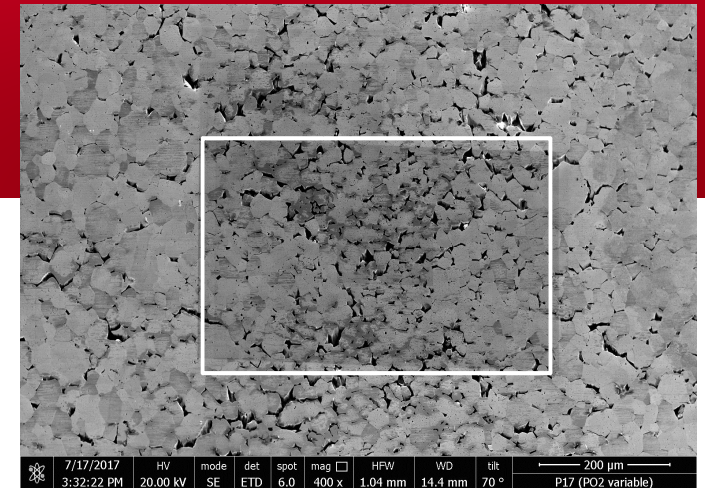
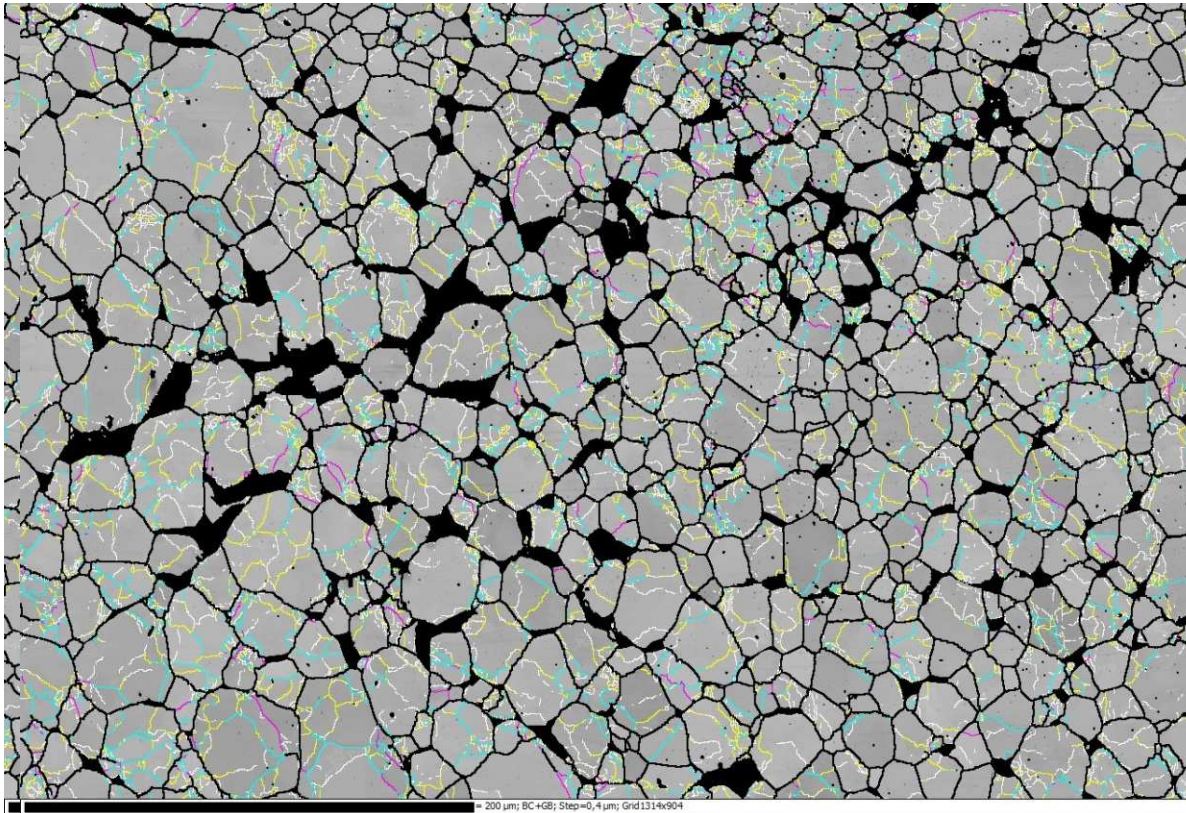

White: 0.25°/ Yellow: 0.5°/ Aqua : 1°/ Pink: 3°/ Black: 5°(non indexed pixels)

- **Damage localisation** and apparent incompatibilities between orientations **increase** with oxygen activity
- Possible sign that diffusion processes proceed at faster rates?

- A set of compression creep experiments carried out at different oxygen pressures in high stress regime: consistent with restoration creep
- Tests are reproducible
- Phenomenological analysis of primary and secondary creep – 4 parameter model satisfactory
- Backed up by 1 and 2 dimensional modelling
- uniaxial hypothesis is relevant for model identification
- Decrease of flow stress with p_{O_2} – consistent with cation diffusion assisted mechanism
- SEM Microstructural analysis reveals
 - Localisation of damage
 - Increased localisation and grain fragmentation with increased p_{O_2}

- Change conditions to different
 - Strain rates: identification of $\dot{\epsilon} \propto K p o_2^\alpha \sigma^n$
 - Temperatures: true activation energy
- Study purely Nabarro-Herring creep
- Systematic 2D simulation: correlation to microstructural study
- Look at different materials: SPS, single crystals and (U,Ce) mixed oxide
- *Relationship between macroscopic/local strains - fragmentation – oxygen activity remains to be understood*
- Parallel may be drawn with response to irradiation?



Acknowledgements

This research is part of the INSPYRE project, which has received funding from the Euratom research and training programme 2014-2018 under Grant Agreement No 754329



INSPYRE

Investigations Supporting MOX Fuel Licensing
in ESNII Prototype Reactors