



**HAL**  
open science

# Two color LIF techniques applied on a two jets mixing flow Challenges and experimental program on a complex mock up

M. Chitt, D. Guenadou, L. Rossi, B. Cariteau, G. Ricciardi

## ► To cite this version:

M. Chitt, D. Guenadou, L. Rossi, B. Cariteau, G. Ricciardi. Two color LIF techniques applied on a two jets mixing flow Challenges and experimental program on a complex mock up. International Symposium on Applications of Laser and Imaging Techniques to Fluid Mechanics, Jul 2018, Lisbon, Portugal. cea-02338613

**HAL Id: cea-02338613**

**<https://cea.hal.science/cea-02338613v1>**

Submitted on 9 Dec 2019

**HAL** is a multi-disciplinary open access archive for the deposit and dissemination of scientific research documents, whether they are published or not. The documents may come from teaching and research institutions in France or abroad, or from public or private research centers.

L'archive ouverte pluridisciplinaire **HAL**, est destinée au dépôt et à la diffusion de documents scientifiques de niveau recherche, publiés ou non, émanant des établissements d'enseignement et de recherche français ou étrangers, des laboratoires publics ou privés.

## Two color LIF techniques applied on a two jets mixing flow: Challenges and experimental program on a complex mock up

Mira CHITT<sup>1</sup>, Benjamin CARITEAU<sup>2</sup>, David GUENADOU<sup>1</sup>, Guillaume RICCIARDI<sup>1</sup>, Lionel ROSSI<sup>1</sup>

1: CEA Cadarache, DEN, DTN\STCP\LTHC, 13115 Saint-Paul-lez-Durance, France

2: CEA Saclay, DEN, DM2S\STMF\LIEFT, 91191 Gif-sur-Yvette Cedex, France.

[mira.chitt@cea.fr](mailto:mira.chitt@cea.fr) [david.guenadou@cea.fr](mailto:david.guenadou@cea.fr)

**Keywords:** LIF, PIV, thermal hydraulics, two jet flow, complex geometry

### ABSTRACT

There are thermal hydraulics issues of upper plenum of sodium cooled reactor ASTRID which can not be studied from past reactors feedback and numerical simulations since the calculation codes do not allow to model these problems with sufficient confidence. Thus in order to validate the numerical approaches and systems concept of ASTRID to fit the codes and simulations for validation and to better understand the complex thermal hydraulic phenomena in order to qualify the design options, we need to investigate temperature and velocity in this complex geometry. Laser Induced Fluorescence and Particle Image Velocimetry are optical methods used to measure temperature and velocity respectively. In all forms of LIF, a laser is used to excite fluorescent species within the flow. Typically, the tracer, an organic fluorescent dye such as Fluorescein or Rhodamine, absorbs a portion of the excitation energy and spontaneously re-emits a portion of the absorbed energy as fluorescence. In our experiments, single dye and two color LIF techniques are used to perform calibrations to study the fluorescence response of the dyes as function of main parameters: dye concentration, laser power, and temperature variation. Regarding PIV, the fluid is seeded with tracer particles then illuminated so that the particles are visible. The motion of the seeding particles is used to calculate velocity and direction of the flow being used. An experiment representative of the mixing flows in the MICAS mock up made up of two jets was designed to develop the LIF and PIV measurement process. The first jet is hot and the second cold, then optical methods for measuring simultaneously temperature by LIF and velocity by PIV is applied on the mock up. The interaction between the two jets at different temperatures and different configurations is studied regarding main dimensionless values such as Reynold's number, Richardson number and Froude number.

---

### I. Introduction:

Advanced Sodium Technological Reactor for Industrial Demonstration ASTRID is a project of construction of a 4<sup>th</sup> generation reactor cooled by sodium. There are thermal-hydraulic issues of upper plenum of ASTRID which can't be studied from past reactors feedback and numerical simulations since the calculation codes do not allow to model these problems with sufficient confidence. Thus in order to validate the numerical approaches and systems concept of ASTRID, it is important to measure temperature and velocity simultaneously using optical measurement techniques.

Figure 1 is a sketch of the actual design of ASTRID. The sodium flows from the external vessel to the upper plenum through the core where it is heated. Around 90% of the sodium ejected from the core is deviated by the Upper Core Structure (UCS) to the upper plenum. The other part flows across the UCS, then to the upper plenum. The hot sodium (550°C) of the upper plenum enters inside the Intermediate Heat Exchangers (IHX) to heat a secondary sodium circuit. This latter is connected to a steam generator. This scheme avoids the primary sodium to be in contact with water in case of leakage. The outlet of the IHX is connected to the external vessel where the sodium is pumped and sent back to the core.

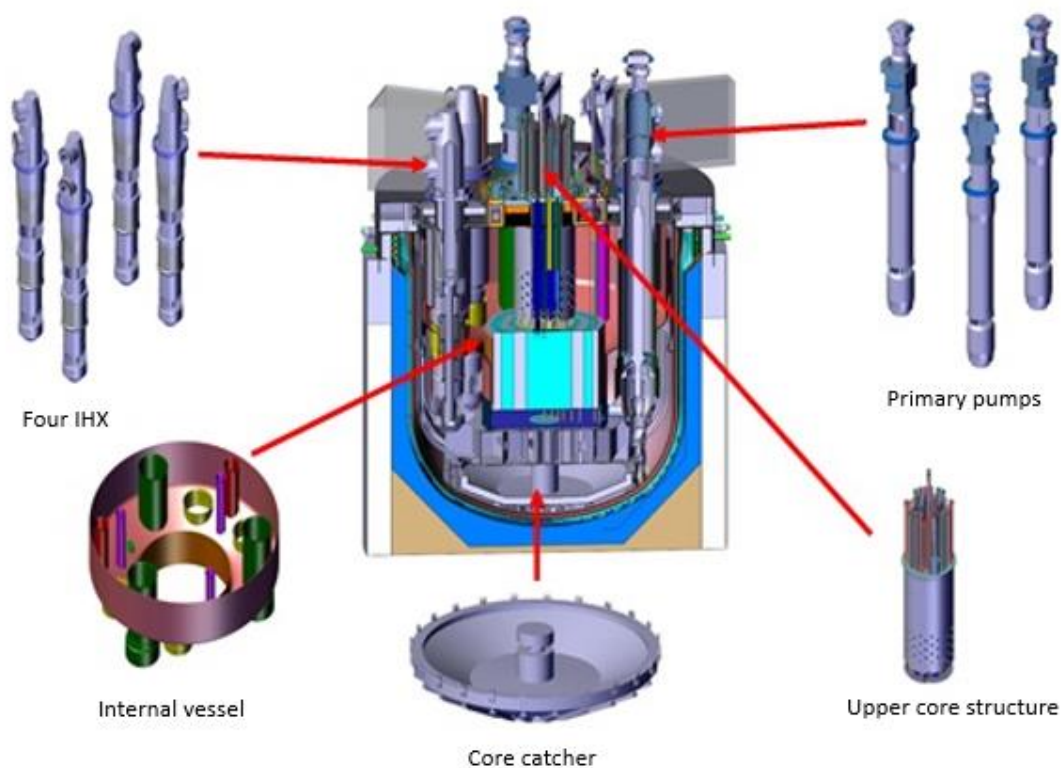

Figure 1: cut view of ASTRID primary circuit

Sodium experiments are very complicated to perform since sodium is opaque and reacts violently with water. Thus it is more practical to perform measurements on a water model since both have similar physical properties in terms of viscosity and density. From what preceded, the MICAS mockup was designed (Figure 2). It is a water model of ASTRID, about 2.5 m diameter and 1.7 m height and made up of PMMA for optical measurements. The challenge in implementing non-intrusive optical techniques to simultaneously measure temperature and velocity on the MICAS mock up resides in designing the experiments so that they are carried out under ambient optical

conditions with accuracy and precision attained as much as possible during the execution. Laser Induced Fluorescence LIF and Particle Image Velocimetry PIV are used to measure temperature and velocity respectively.



Figure 2: MICAS Mock up

Laser Induced Fluorescence (LIF) is a quantitative, non-intrusive technique for liquid flows commonly used to excite a fluorescent species within the flow. Typically, the tracer, an organic fluorescent dye such as fluorescein or rhodamine, absorbs a portion of the excitation energy and spontaneously re-emits a portion of the absorbed energy as fluorescence. The fluorescence is measured optically and used to infer the local concentration of the dye. The fluorescence intensity  $F$  at a specified point is modelled by equation 1.

$$F = I_0 \varphi (1 - e^{-\varepsilon b C}) \quad (1)$$

$$F = I_0 \varphi \varepsilon b C \quad (2)$$

where  $I_0$  is the incident light flux,  $\varphi$  is the quantum efficiency,  $\varepsilon$  is an absorption coefficient,  $b$  is the thickness of the laser sheet and  $C$  is the concentration of the dye solution. Thus, a linear equation is obtained when the product  $\varepsilon b C$  is small as seen in equation 2. A dye is a necessary component of LIF. The suitability of a dye is based on an absorption spectrum that is compatible with the laser excitation wavelength. The fluorescent tracer must be water-soluble with high quantum efficiency so that signal strength is maximized. It must exhibit enough temperature

dependence over a suitable temperature range and must be photo-stable under experimental conditions that yield detectable emission. Plus, the absorption and emission of the dye must be spectrally separable. Regarding the types of LIF technique, there exist three main methods focusing on the dyes used. One color LIF technique is the method in which one single fluorescent dye and one spectral band of detection are used. In general, the linearity of the fluorescence signal with respect to the incident laser energy and dye concentration is reported. Such experiments were the first to be conducted in the temperature measurement field. From these experiments, researchers were able to identify the characteristics of the organic dyes such as the excitation wavelength, temperature dependent emission percentage and temperature range.

In the two color two dye LIF techniques, the temperature is determined from the ratio of the signal of two dyes, which have highly different temperature sensitivities. That is one of the dyes should be sensitive to temperature and the other should not or only very weakly. This technique eliminates the laser intensity dependence faced in the one color LIF.

In our experiments and from what has preceded, single dye and two dye two color LIF techniques seem very appealing since in addition to the accuracy of these techniques, it is also interesting to make comparison between the results of each one. Starting from this point, experiments regarding one color LIF were carried out.

Calibration experiments were performed to study the fluorescence response of four dyes: Classical Fluorescein (also called Disodium fluorescein;  $C_{20}H_{10}O_5Na_2$ ), FL27 (or Fluorescein 548;  $C_{20}H_{10}Cl_2O_5$ ), Rh6G and RhWT as function of three main parameters: dye concentration, laser power and temperature variation.

The dyes are in powder form so in order to prepare a homogeneous solution, a concentrated one is prepared at first for each dye, then it is diluted several times to get the required range of concentration needed for the study as shown in the figure 3.



Figure 3: Dyes prepared FL27, Rh6G and RhWT



The experimental setup shown in figure 4 consists of a pulsed 532 nm Nd:YAG laser, camera, heater and an aquarium of experimental volume 30 L.

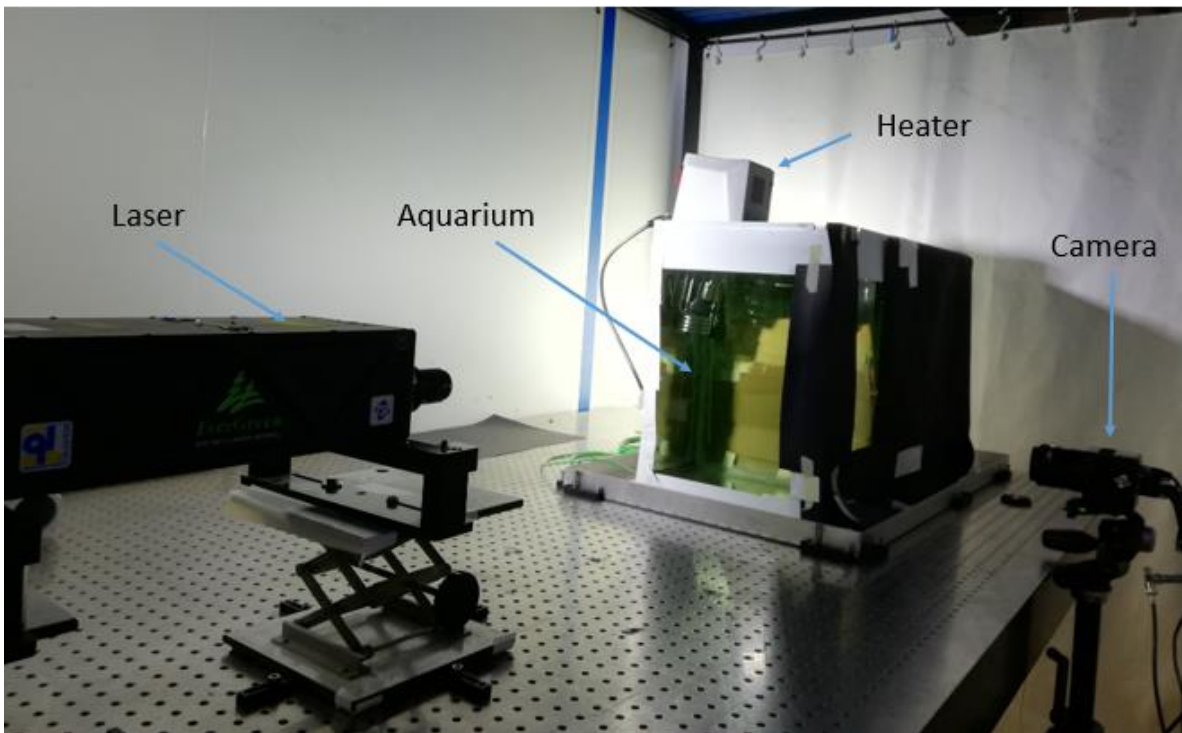

Figure 4: Experimental setup LIF

A dark image and a reference image (solution without a dye) are taken before each experiment. Regarding RhWT, experiments were applied on concentrations between  $2 \cdot 10^{-5}$  g/L and  $2 \cdot 10^{-4}$  g/L. The solution is well stirred before each experiment.

At each concentration, the temperature was varied between 18°C and 45°C.

The laser power was maintained constant and 100 to 1000 images were taken at each condition for post treatment.

Same experiments were done using Rh6G but at lower concentrations.

Figure 5 shows the fluorescence response of dyes RhWT and Rh6G as function of temperature variation (°C).

Results showed that the variation of counts decreases very slowly with the increase in temperature for Rh6G and that RhWT is not sensitive to temperature variation.

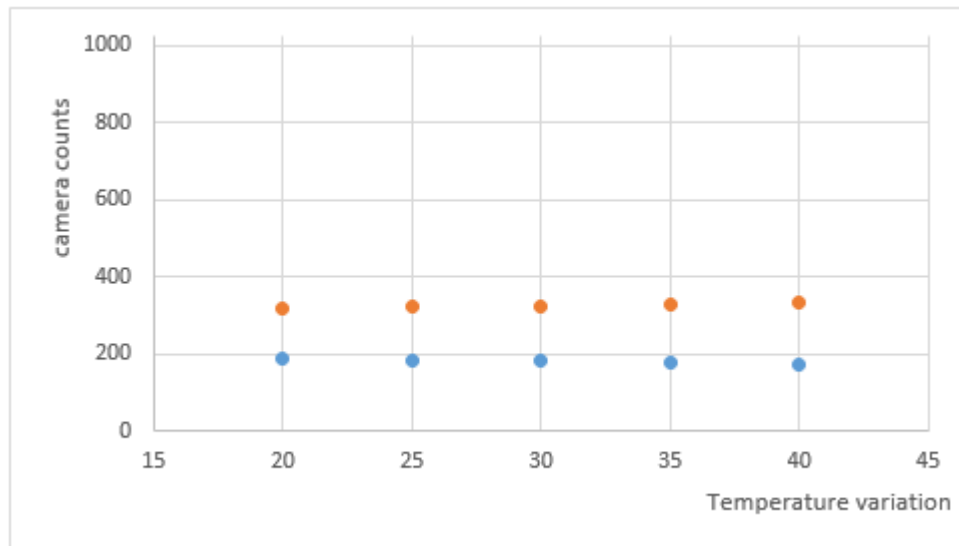

Figure 5: Variation of response RhWT (blue) and Rh6G (orange) as function of temperature (°C)

Thus both dyes can be used in our two color LIF experiments to eliminate the effect of laser intensity.

## II. Two Jet Flow Apparatus:

On the other hand, as the MICAS Mock-up exhibits complex mixing flows, an experiment was designed to study such configurations. The objective of this experiment is to design a representative prototype from the point of view of the dimensional analysis of the thermal hydraulics (jet flow, plumes, buoyancy,...) of the core of the MICAS model. For this fact, the mixture of the two jets of different temperatures must be studied. The first jet is being hot and the second cold such as the case in the MICAS mock-up and then optical methods for measuring temperature (LIF) and velocity (PIV) simultaneously will be applied on the prototype. The prototype aims to study the interaction between two jets at different temperatures and these can be vertical or horizontal. In this study, three main dimensionless values will be studied, Reynold's number, Richardson number and Froude number. The flow in one jet is laminar and turbulent in the second. When the flow rate of each jet is changed, several cases will be studied such as the interaction between a fountain and a jet, buoyant plumes in a turbulent environment,... These studies will be achieved by the variation of Richardson number by varying the distance separating the two jets which is a main factor here. Another challenge exists in the application of LIF and PIV simultaneously on this rig. For this reason, the characterization system requires two perpendicular transparent faces. The prototype consists of a tank having transparent walls for optical access

which allows the implementation of LIF and PIV simultaneously. It is connected to a hydraulic loop consisting of three tanks.

The configuration of the rig can be shown in figure 6. It is a cube of about  $1\text{m}^3$  of volume composed of three transparent faces of optical quality. The optical access is of dimensions  $1\text{m}$  by  $1\text{m}$ . The non-transparent side is removable and the top side of the test section is equipped with an overflow tray to achieve identical exit conditions.

Two color LIF will be directly applied on this set up using two dyes FL 27 and Rh6G to then be able to perform LIF and PIV at the same time after profiting from the data collected and experiences acquired from previous stages.

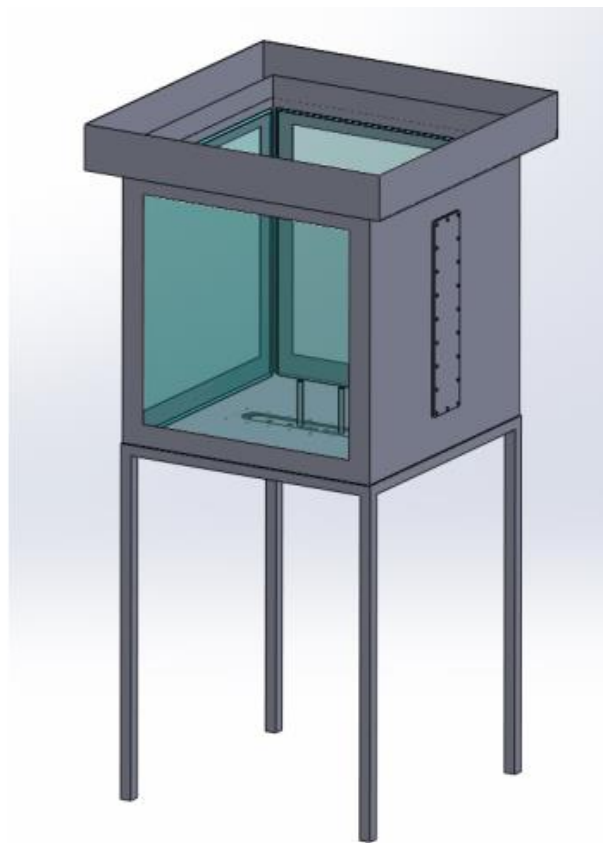

Figure 6: 3D view of main test section

### III. Conclusion:

By the steps followed, this work will contribute to the studies of emission response of fluorescein dyes with respect to incident laser intensity and dye concentration for laser excitation at  $532\text{ nm}$ . In conclusion, the simultaneous application of LIF and PIV first on a simple geometry then on a complex one will enable us to understand the complex thermal hydraulic phenomena in order to qualify the design options concerning the upper plenum of ASTRID.



- Proceeding of Nureth 16, Chicago: Guenadou D, Tkatschenko I, Aubert P (2015) Plateau Facility in Support to Astrid and the SFR Program: An Overview of the First Mock-Up of the Astrid Upper Plenum, Micas.
- Article by Crimaldi P(2008) Planar laser induced fluorescence in aqueous flows, *Experiments in Fluids*, Vol. 44, Issue 6, pp. 851-863.
- Article by Sutton J, Fisher and Fleming J (2008) A laser induced fluorescence measurement for aqueous fluid flows with improved temperature sensitivity, *Experiments in Fluids*, Vol. 45, pp. 869-881.
- Article by Copetta J and Rogers C (1998) Dual emission laser induced fluorescence for direct planar scalar behavior measurements, *Experiments in Fluids* , Vol. 25, Issue 1, pp. 1-15.
- Thesis by Garcia J.M (2011) Experimental Study of Free Surface Mixing in Vortical and Chaotic Flows.
- Article by Lemoine F, Guillard F and Bruchhausen M (2005) Instantaneous measurement of two-dimensional temperature distributions by means of two-color planar laser induced fluorescence (PLIF), *Experiments in Fluids*, Vol. 38, pp 123-131.
- Article by Lemoine F, Chaze W, Caballina O and Castanet G (2016) The saturation of the fluorescence and its consequences for laser-induced fluorescence thermometry in liquid flows, *Experiments in Fluids* 57:58.
- Article by Coolen M, Kieft R, Rindt C and Steenhoven A (1999) Application of 2-D LIF temperature measurements in water using a Nd : YAG laser, *Experiments in Fluids* 27,pp 420-426.
- Article by Mizushima T, Ogino F, Takeuchi H, and Ikawa H (1982) An Experimental Study of Vertical Turbulent Jet with Negative Buoyancy, *Wärme- und Stoffübertragung* 16, 15-21.
- Article by Wygnanski I AND Fiedlert H (1970) "The two-dimensional mixing region" *J. Fluid Mechanics*, vol. 41, part 2, pp. 327-361.