



**HAL**  
open science

# Trends Emerging from a Systematic Analysis of a Decade of Fluctuation Reflectometry Measurements on Tore Supra

R. Sabot, Y. Sun, S. Heuraux, G. Verdoolaege, X. Garbet, S. Hacquin, G. Hornung

► **To cite this version:**

R. Sabot, Y. Sun, S. Heuraux, G. Verdoolaege, X. Garbet, et al.. Trends Emerging from a Systematic Analysis of a Decade of Fluctuation Reflectometry Measurements on Tore Supra. 14 th International Reflectometry Workshop, May 2019, Lausanne, Switzerland. cea-02288920

**HAL Id: cea-02288920**

**<https://cea.hal.science/cea-02288920>**

Submitted on 16 Sep 2019

**HAL** is a multi-disciplinary open access archive for the deposit and dissemination of scientific research documents, whether they are published or not. The documents may come from teaching and research institutions in France or abroad, or from public or private research centers.

L'archive ouverte pluridisciplinaire **HAL**, est destinée au dépôt et à la diffusion de documents scientifiques de niveau recherche, publiés ou non, émanant des établissements d'enseignement et de recherche français ou étrangers, des laboratoires publics ou privés.

DE LA RECHERCHE À L'INDUSTRIE



[www.cea.fr](http://www.cea.fr)

# Trends Emerging from a Systematic Analysis of a Decade of Fluctuation Reflectometry Measurements on Tore Supra

R. Sabot<sup>1</sup>, Y. Sun<sup>1</sup>, S. Heuraux<sup>2</sup>, G. Verdoolaege<sup>3,5</sup>,  
X. Garbet<sup>1</sup>, S. Hacquin<sup>1,4</sup>, G. Hornung<sup>3</sup>  
& Tore Supra team

<sup>1</sup> CEA, IRFM, F-13108 Saint Paul Lez Durance, France

<sup>2</sup> ILL UMR 7198 CNRS, Université de Lorraine, F-54011 Nancy, France

<sup>3</sup> Department of Applied Physics, Ghent University, 9000 Gent, Belgium

<sup>4</sup> Eurofusion PMU Culham Science Centre, Culham, OX14 3DB, UK

<sup>5</sup> LPP-ERM/KMS, B-1000 Brussels, Belgium

24/05/2019

Transport is dominated by turbulent instabilities. Many progresses, but turbulence remains an issue.

A **Data-driven discovery** approach could be effective to extract new information:

- 1) The complexity of the problem is great
- 2) Parameters controlling turbulence are numerous & of different types

From 2002 (core reflectometer installation) to 2011 (Tore Supra's last plasma) **350 000 measurements** at fixed frequency were performed over **6000 discharges**.

Could we extract ***new observations*** from this big database ?

## **I. Introduction**

## **II. Parametrization of fluctuation frequency spectra**

## **III. Radial profiles of broadband contribution**

## **IV. Collisions and spectrum characteristics**

## **V. Conclusions and perspectives**

## **II. Parametrization of fluctuation frequency spectra**

# A data reduction is required

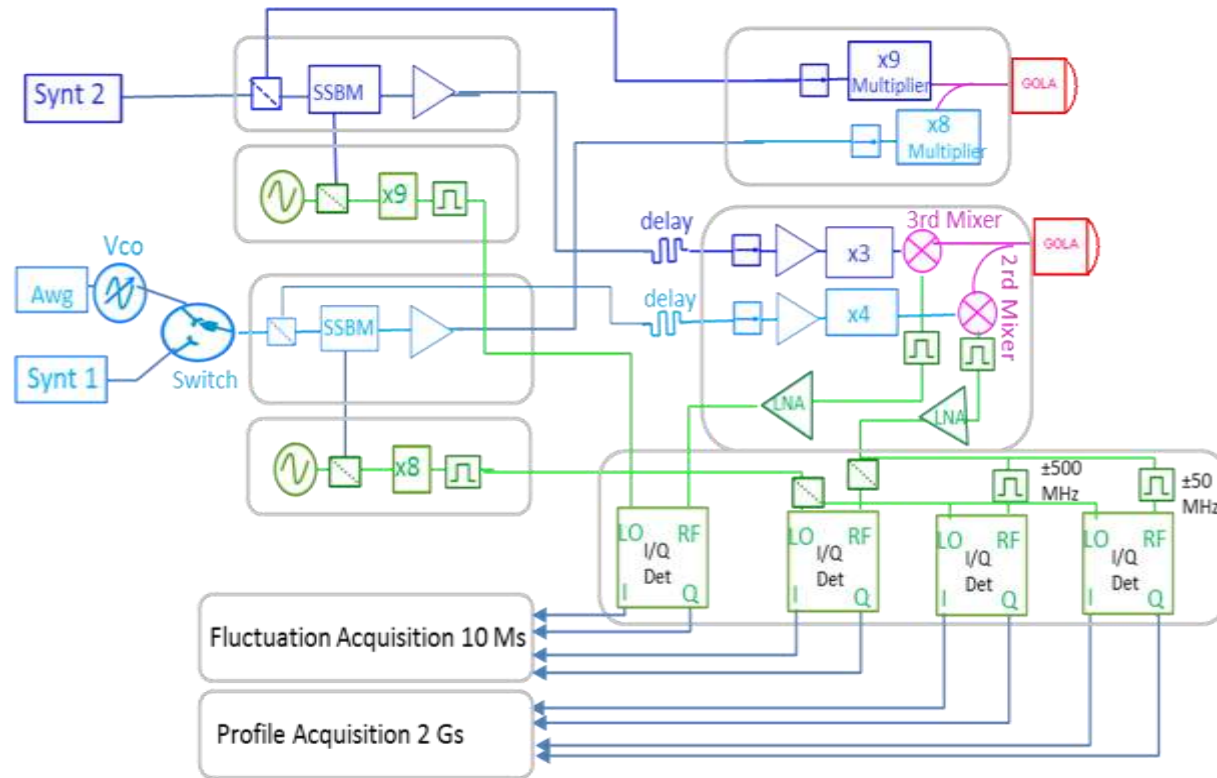

typ: 2\*20 steps of 10 ms (40\*10 000 complex values)  
several times/shot

Frequency spectrum  
( $N_{FFT} \sim 1,000$ )

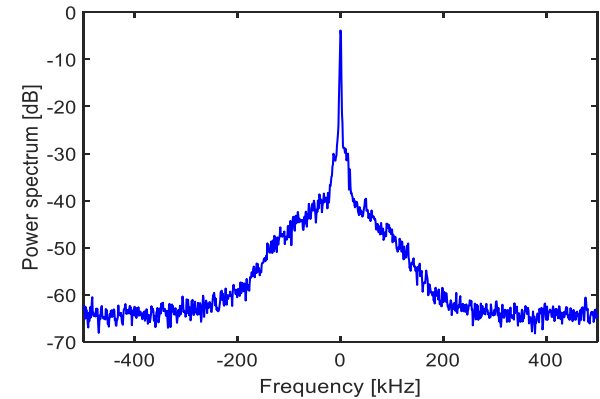

1 step → 1 spectrum  
500 to ~ 1000 values (A(f))

# A data reduction is required

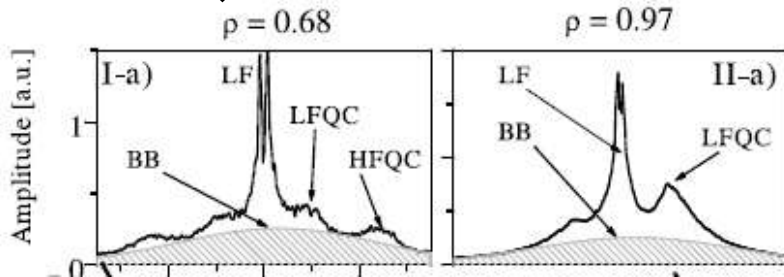
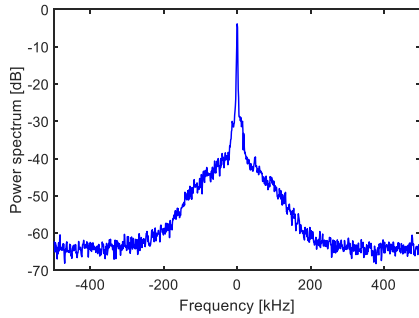

*Vershkov NF 2005*

*#91321: 2.2422–2.4971s Krämer-Flecken NF 2004*

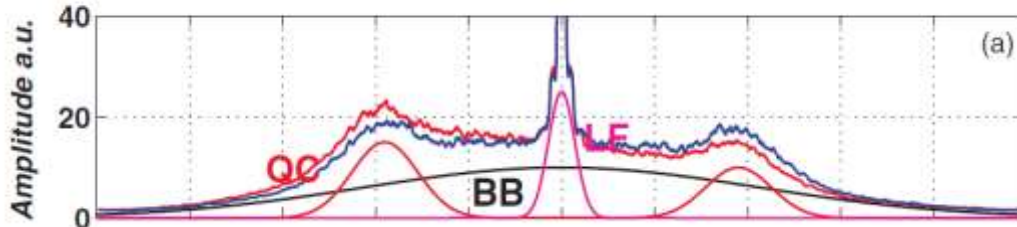

Decomposition → 1 spectrum  $\cong$  few components

Frequency spectrum  
( $N_{FFT} \sim 1,000$ )



Decomposition



Few parameters  
( $N_p \sim 10$ )



database

## Decomposition

- ❑ Noise (N) level → 1 parameter
- ❑ Direct current (DC) } 2 Gaussian
- ❑ Low-frequency (LF) } 6 parameters
- ❑ Broadband (BB) component
- ❑ MHD and quasi-coherent (QC) modes not considered yet (narrow → modest contribution)

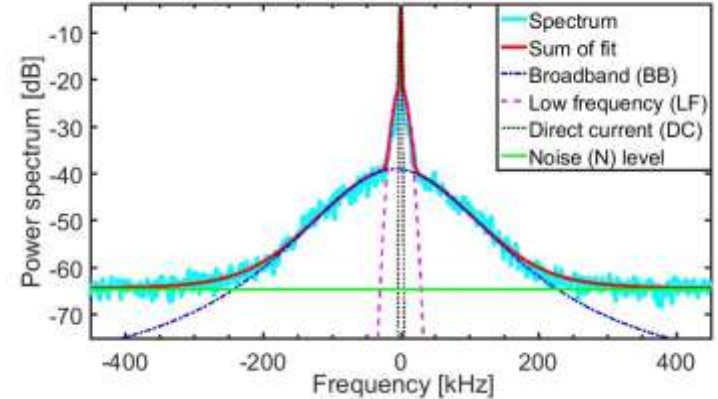

## 4 parameters needed to fit the BB ≠ shapes

- ❑ Voigt function (Sun IRW13)
- ❑ Generalized Gaussian  $Ae^{\left(\frac{x-\mu}{\sigma}\right)^\beta}$
- ❑ FFT of Taylor function [Hennequin EPS99] complex link btw param & shape

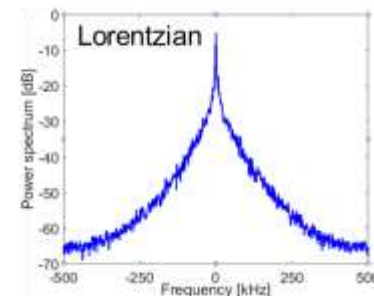
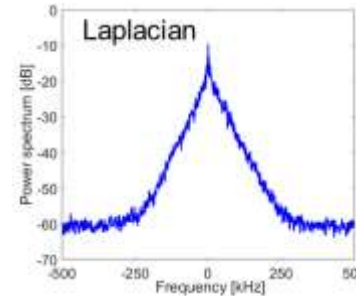



- The spectrum are normalized to the total power:

$$1 \approx \frac{\int \text{BB+LF+DC+N } dF}{\text{Total power of spectrum}} \approx \frac{\int \text{BBdF}}{\int \text{BBdF} + \int \text{LFdF}} + \frac{\int \text{LFdF}}{\int \text{BBdF} + \int \text{LFdF}} \sim E_{\text{BB}} + E_{\text{LF}}$$

- Cost function is done in linear (LF) and logarithmic (shape) scales

$$F_{\text{cost}} = (1 - w) \times \frac{|\lg(S_{\text{fit}}) - \lg(S)|^2}{\int [\lg(S)]^2 df} + w \times |S_{\text{fit}} - S|^2 \quad \text{with } w = 0.5$$

- Minimization using interior-point algorithm with several initial guess

- ✓ The GG model
  - ➔  $N_{iv} = 3$
- ✓ The Taylor model
  - ➔  $N_{iv} = 5$

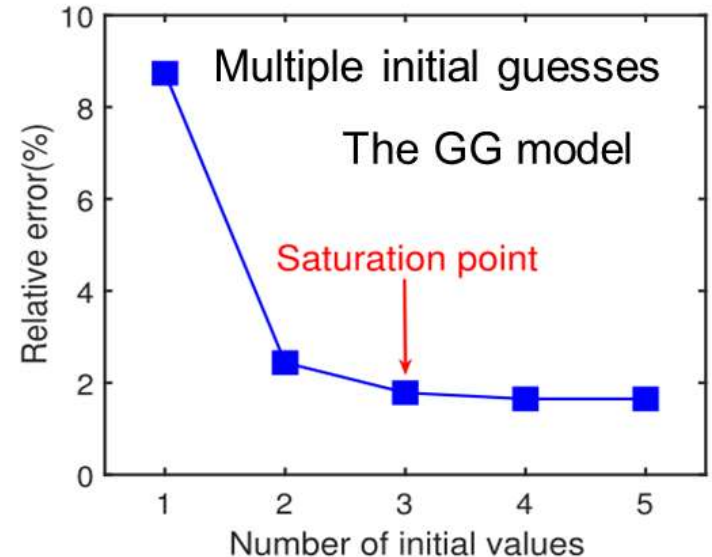

350,000 spectra from 6,000 discharges with Ohmic, LH, ICRH and few ECRH

- Global operating parameters:  $B_{t,0}, I_p, R, a, q_\psi, N_l$  and more
- Diagnostic characteristics: acquisition parameters, probing frequencies, ...
- cutoff positions  $\rho_c$  (density profiles from 10 channel interferometry inversion)
- Local plasma parameters (at  $\rho_c$ ):  $n_e, T_e, B_t, L_\epsilon, (\nabla T_e, \nabla n_e), \dots$
- Turbulence properties: 11 parameters from the parametrization model.

Index	$\rho$	$B_{t,0}$	$I_p$	$q_\psi$	$n_e$	$T_e$	$E_{BB}$	$W_{BB}$	$\beta_{BB}$	...
1	0.65	3.86	1.0	3.64	3.5	2	0.1	50	...	...
2	0.54	3.46	1.0	3.63	4.0	3	0.5	100	...	...
...	...	...	...	...	...	...	...	...	...	...

- For physics studies, “bad” data are excluded: low S/N, strong BB Doppler,  $r/a > 0.6$  (ripple → strong Doppler)

### **III. Radial profiles of broadband contribution**

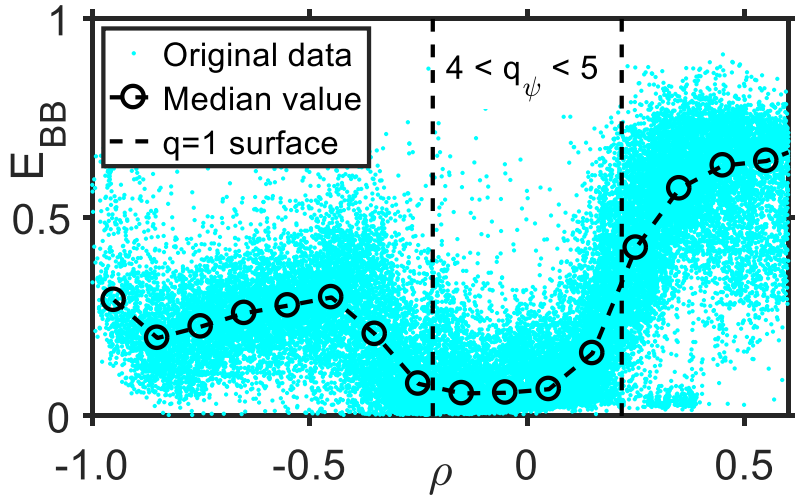

## Radial profiles of $E_{BB}$ in Ohmic

- The basin inside  $q=1$  is recovered [1]
- Width of this basin scales with  $a/q_\psi$
- Shift wrt  $q \sim 1$  explained by the  $\neq$  between interferometry & reflectometry  $n_e$  profiles

## Radial profiles in LOC/SOC

LOC/SOC threshold from the database

$$N_{LOC/SOC} \approx 2.6 \times I_p \text{ (MA)}$$

- Basin observed in LOC & SOC
- In the basin, but also at all positions

$$E_{BB}^{SOC} > E_{BB}^{LOC}$$

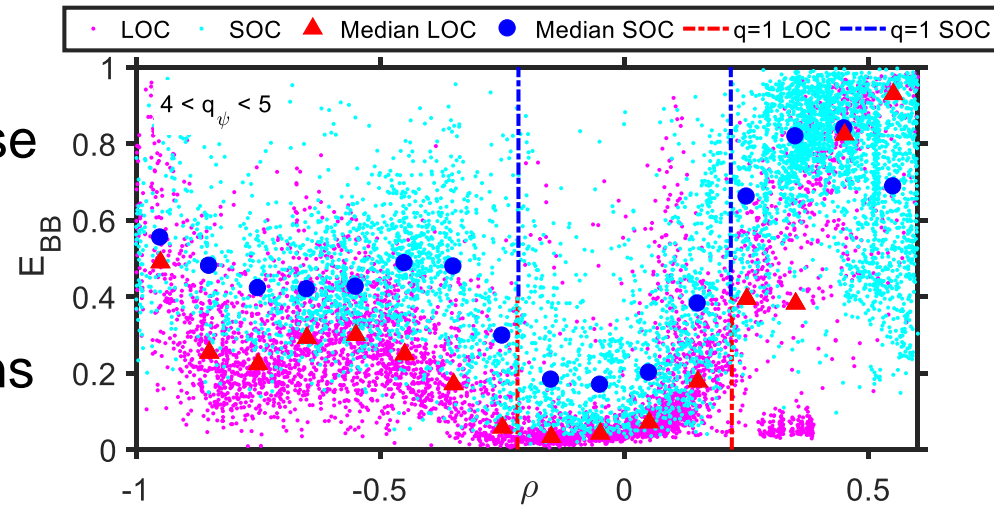

[1] Sirinelli PhD 2006

## Pure ICRH

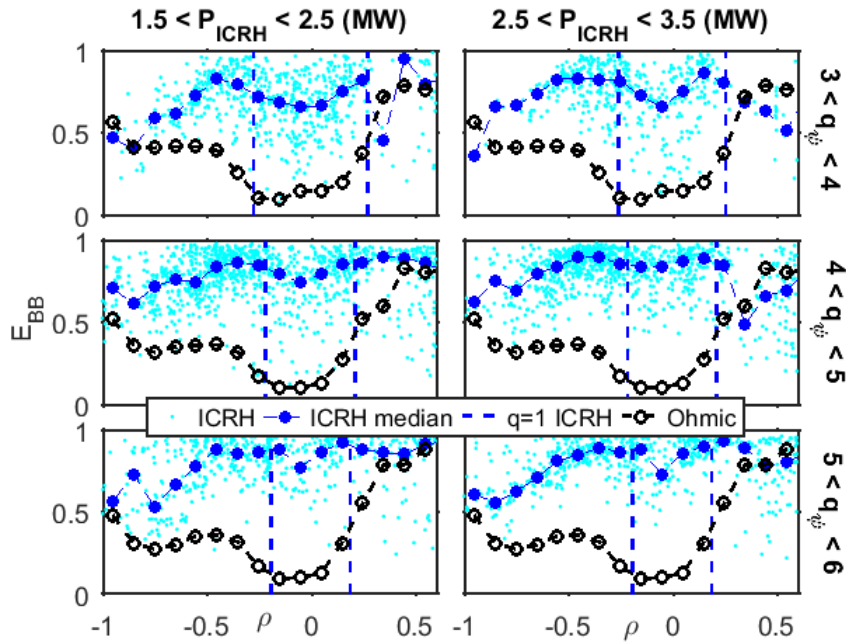

High  $E_{BB}$  ( $>0.5$ ) even at low  $P_{ICRH}$   
 The basin disappears at high  $P_{ICRH}$

## Pure LH

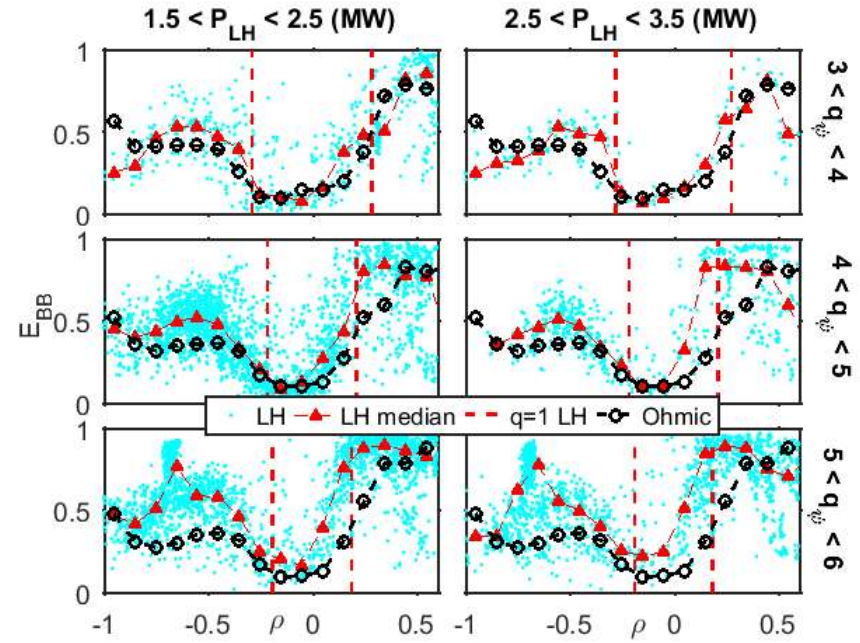

$E_{BB}$  slightly above Ohmic  
 Basin remains even at high  $P_{LH}$

Similar confinement times cannot explain the  $\neq$  BB contribution

## **IV. Collisions and spectrum characteristics**

Many parameters tested to explain ICRH vs LH differences

→ density emerged as a key ( $E_{\text{BB}} \nearrow$  with  $n_e \nearrow$ )

→ but  $n_e$  threshold depends on  $P_{\text{add}}, q_\psi \dots$

Clearer results obtained with **the effective collisionality**

$$\nu_{\text{eff}} = \nu_{ei} / \omega_{De}$$

$\nu_{ei}$ : electron/ion collision freq. &  $\omega_{De}$ : curvature drift freq.

$\nu_{\text{eff}}$  can be approximated by [1]

$$\nu_{\text{eff}} \sim 0.1 R Z_{\text{eff}} n_e T_e^{-2} \quad (n_e \text{ in } 10^{19} \text{ m}^{-3}, T_e \text{ in keV})$$

[1] C. Angioni *PPCF* 2003

Ohmic

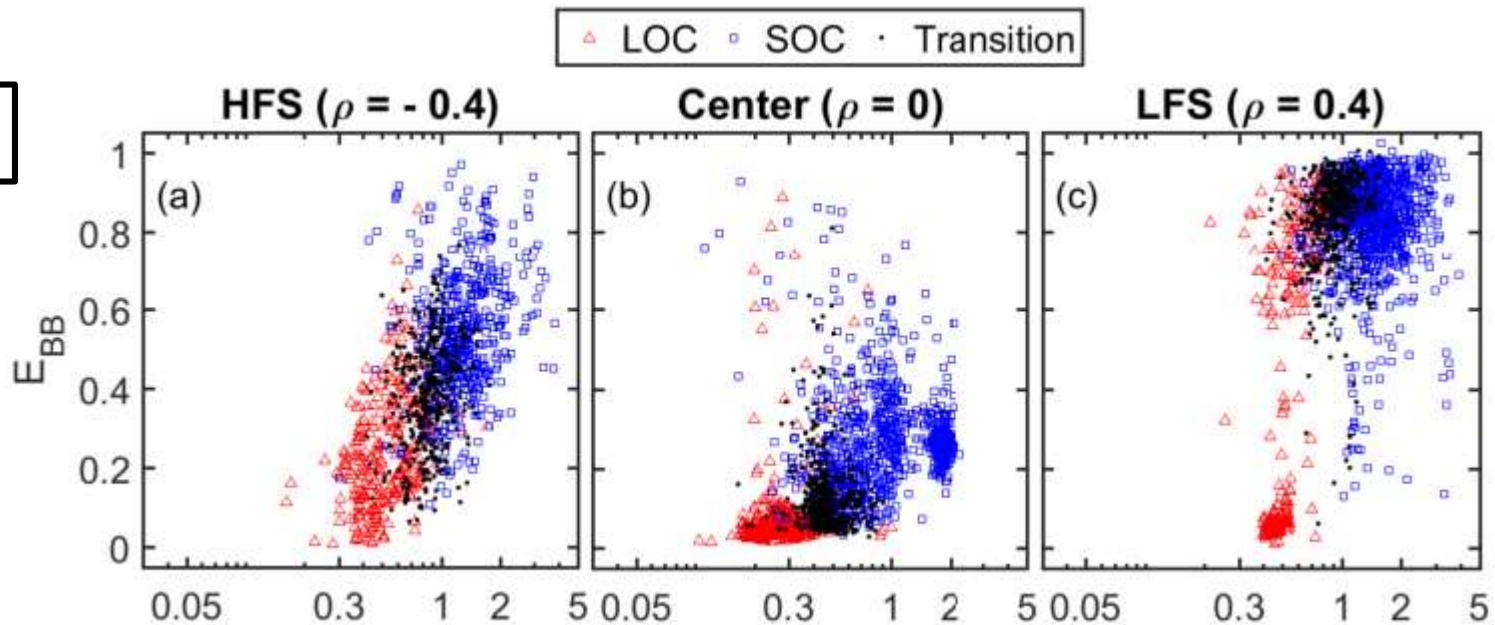

Y. Sun POP 2019

- $E_{BB}$  increases with local  $v_{\text{eff}}$
- LOC/SOC transition ( $0.9 \sim 1.1 N_{LOC/SOC}$ ) around  $v_{\text{eff}} \sim 0.5 - 1$
- HFS: increase from low  $E_{BB}$  in LOC to  $E_{BB} \sim 1$  in SOC
- Center: low  $E_{BB}$  in LOC & transition, up to  $E_{BB} \sim 0.5$  in SOC
- LFS: results less clear due to saturated  $E_{BB} \sim 1$



L-mode

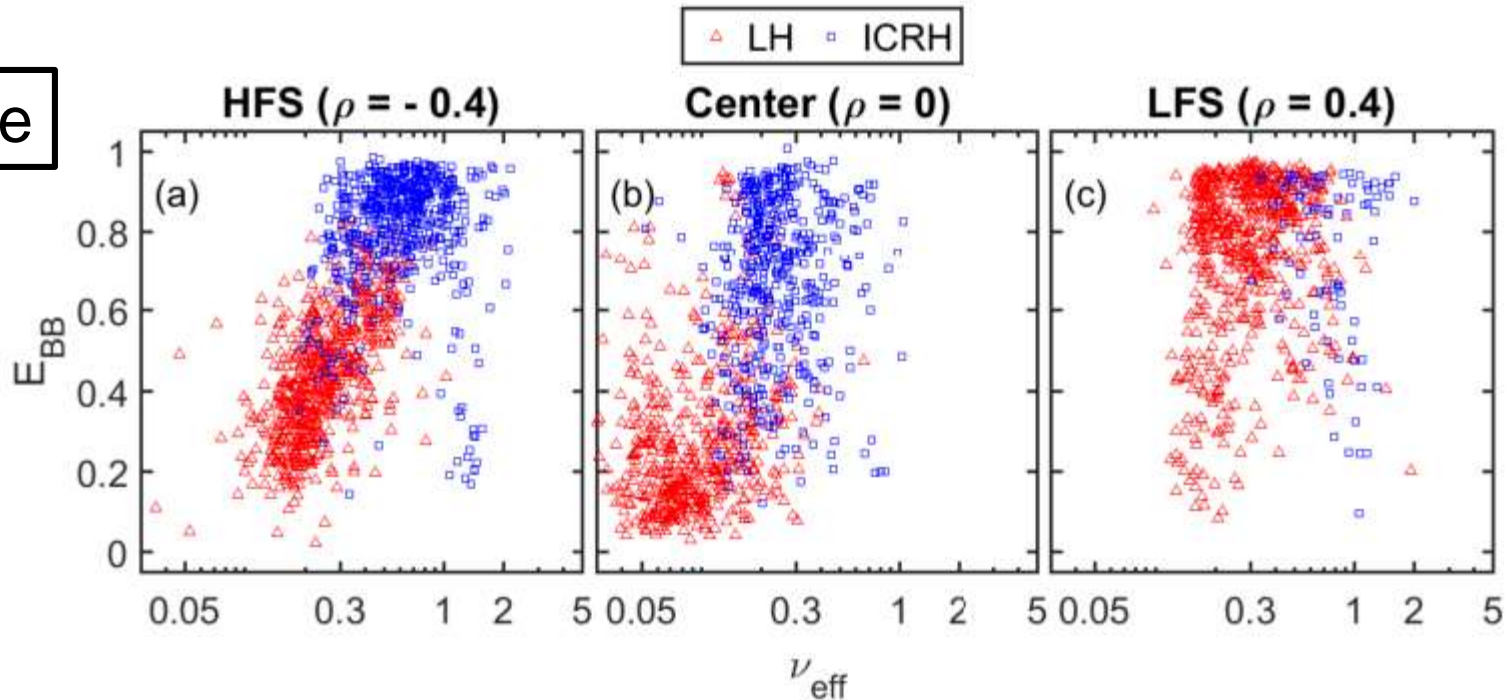

- Similar trends as in Ohmic
- Most LH discharges at **low**  $\nu_{\text{eff}}$  ( $<0.5$ )
- most ICRH ones at high  $\nu_{\text{eff}}$  ( $>0.3$ ) because of higher density for better ICRH coupling

GENE simulations [1,2] performed for a Tore Supra Ohmic ne scan showed

- BB component narrower in LOC(TEM) than in SOC(ITG)
- in TEM, the spectra exhibits a narrow LF component (ZF)
- In ITG, this LF component is integrated in the BB component.

The trends of spectrum modifications:

$E_{BB} \nearrow$  &  $E_{LF} \searrow$  with increasing  $\nu_{eff}$   
are compatible with the simulation results

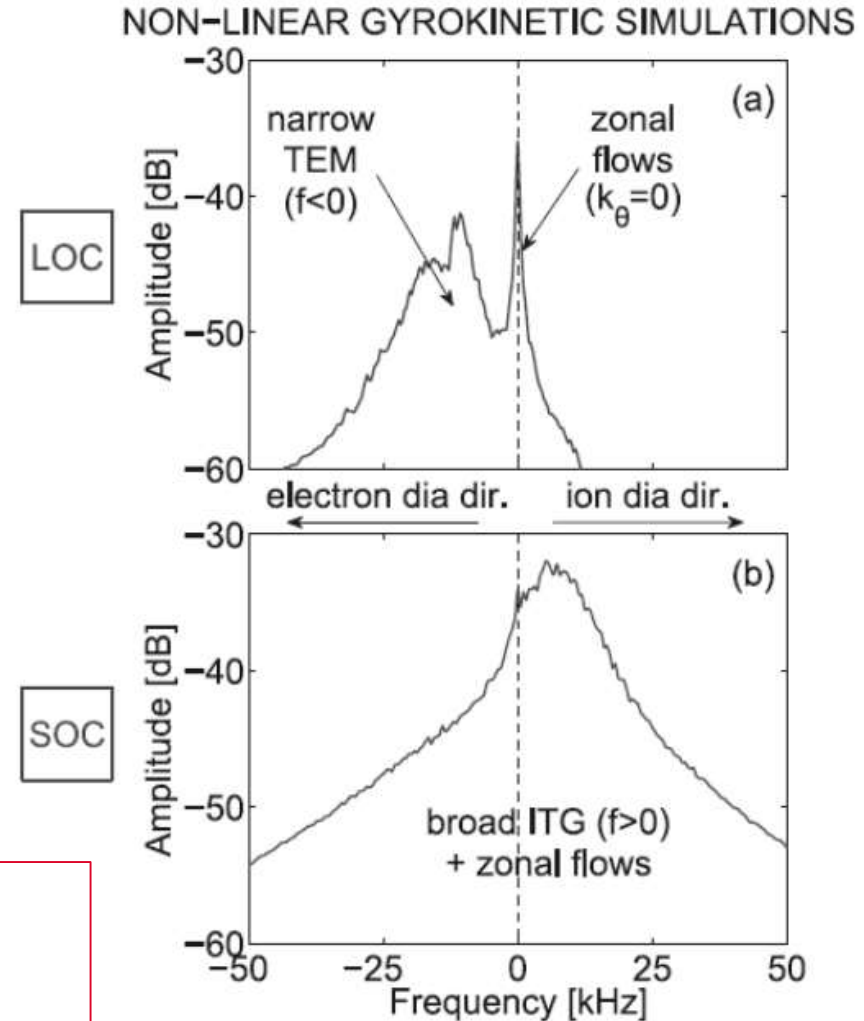

[1] Arnichand PPCF 2016

[2] Citrin PPCF 2017

Width of the LF component ( $W_{LF}$ )  
in Ohmic

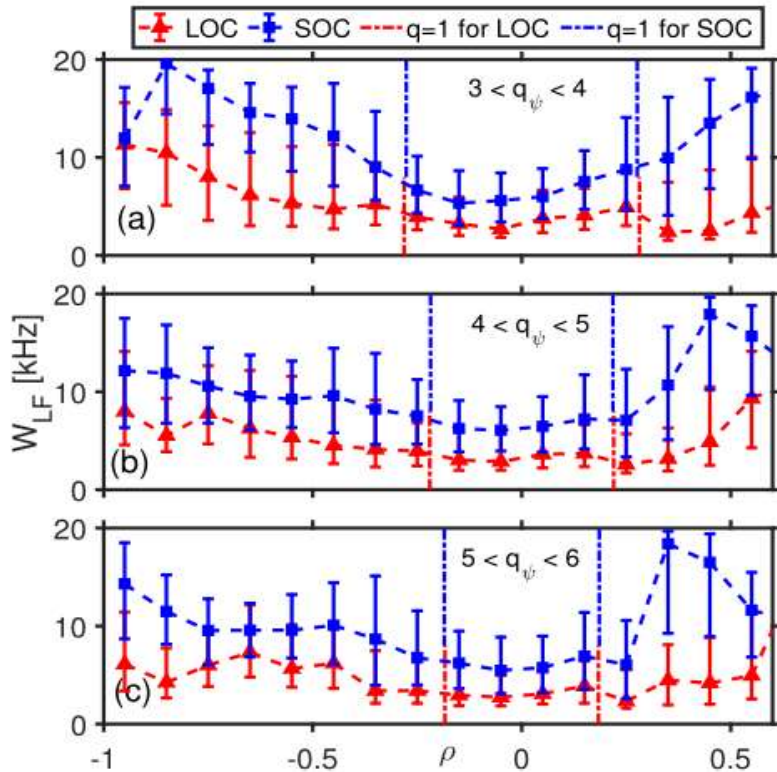

The LF width is low in LOC and  
much higher in SOC

Width of the LF component ( $W_{LF}$ )  
in L-mode

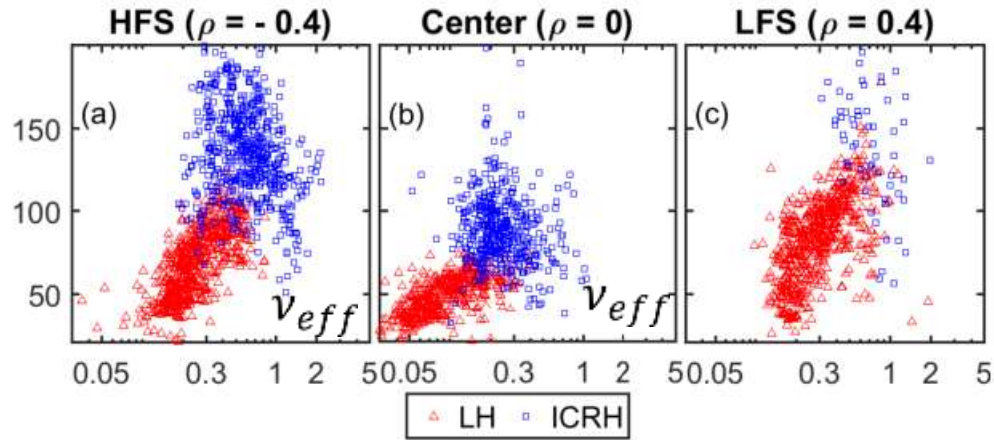

The BB width increase with  $\nu_{eff}$   
- regular trend in LH plasmas  
- wider and large dispersion in ICRH

During LOC/SOC transition, TEM stabilization  $\rightarrow$   $\searrow$   $n_e$  peaking [1,2]

A similar trend is observed in L-mode

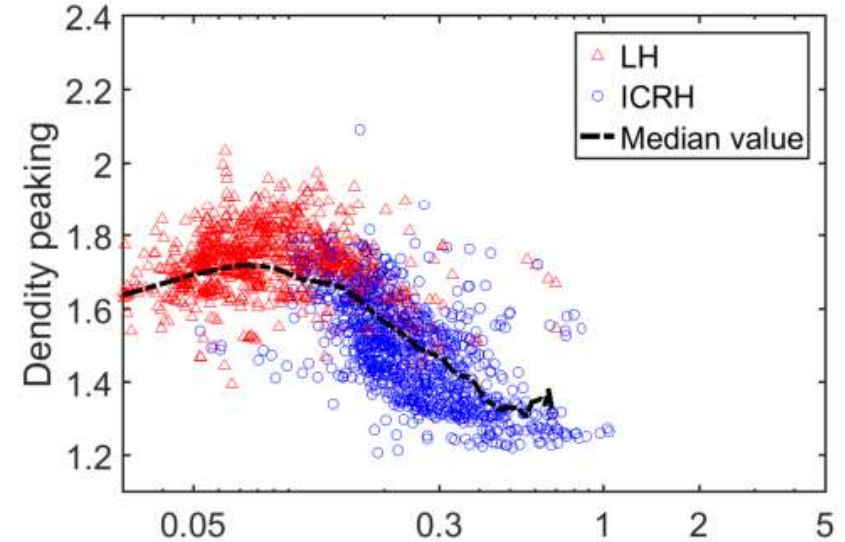
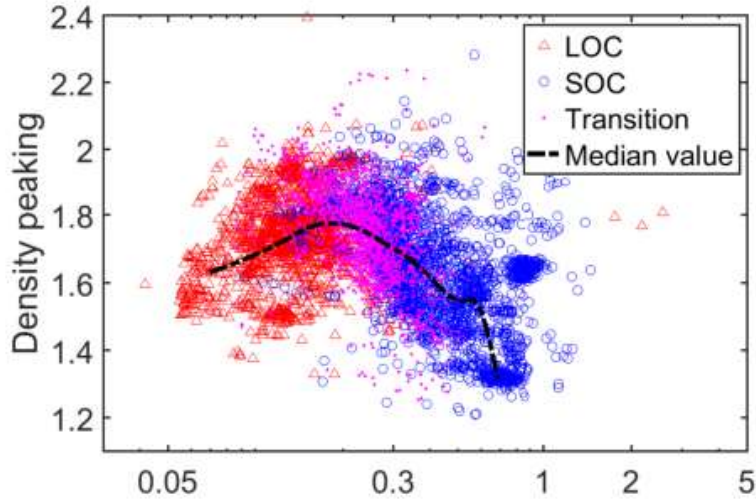

This trend is recovered. Peaking is maximum in the intermediate regime.

Lower slope in LH could be due to lower  $E_{//}$  (Ware pinch  $\searrow$ )

TEM stabilization  $\rightarrow$  inversion of the thermodifusion pinch from inward (TEM) to outward (ITG)  $\rightarrow$  lower peaking

[1] C. Angioni PPCF 2003  
[2] C Bourdelle, PPCF 2005

## **V. Conclusions and perspectives**

- Parametrization reduces the  $\sim 10000$  values of a fluctuation (fixed freq) reflectometry measurement to handful (11) parameters
  - ➔ database of 6000 Tore Supra discharges (350,000 spectra)
  
- Trends and patterns have emerged
  - Basin inside  $q=1$  extended to all  $q_{\psi}$  & LOC/SOC.  
Its width and position linked to  $q=1$  surface ( $a/q_{\psi}$ )
  - Collisionality  $\nu_{\text{eff}}$  seems to control the spectrum shape.
  - Modification of the instability regime was proposed to explain the impact of collisions. This interpretation is supported by other spectrum parameters and the analysis of the density peaking.
  
- Gyro-kinetic simulations and full-wave reflectometry simulations are required to confirm this interpretation as well as to dedicated experiments with controlled & well measured parameters.



- A similar database will be built fore core reflectometer data on WEST. How the elements will compare to Tore Supra ?
- Outliers in the database: some are understood (hardware failure), others need to be investigated
- New parameters could be added to fit other components (quasi-coherent (QC) modes), but criteria should be implement to avoid over-fitting (pattern recognition, NN ?)

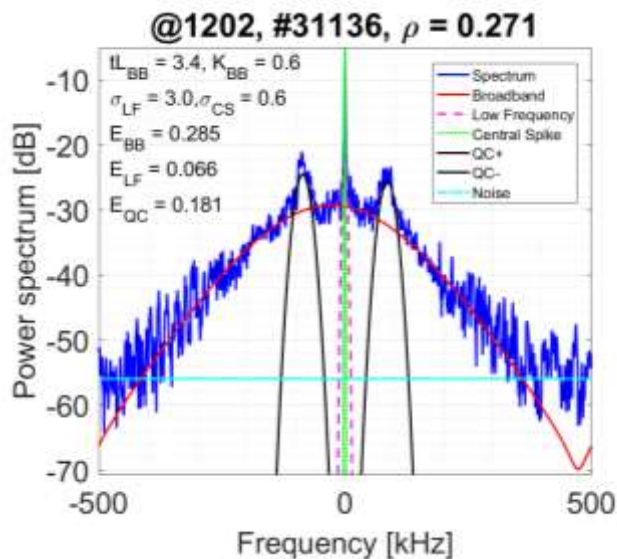

- 4 parameters added to fit the QC modes
- $A_+$  &  $A_-$  amplitudes
  - Position & width

**Back up**



The generalized Gaussian (GG) function:

$$C_{BB}^{GG} = A_{BB} \exp \left[ - \left( \frac{|f - \mu_{BB}|}{\alpha_{BB}} \right)^{\beta_{BB}} \right]$$

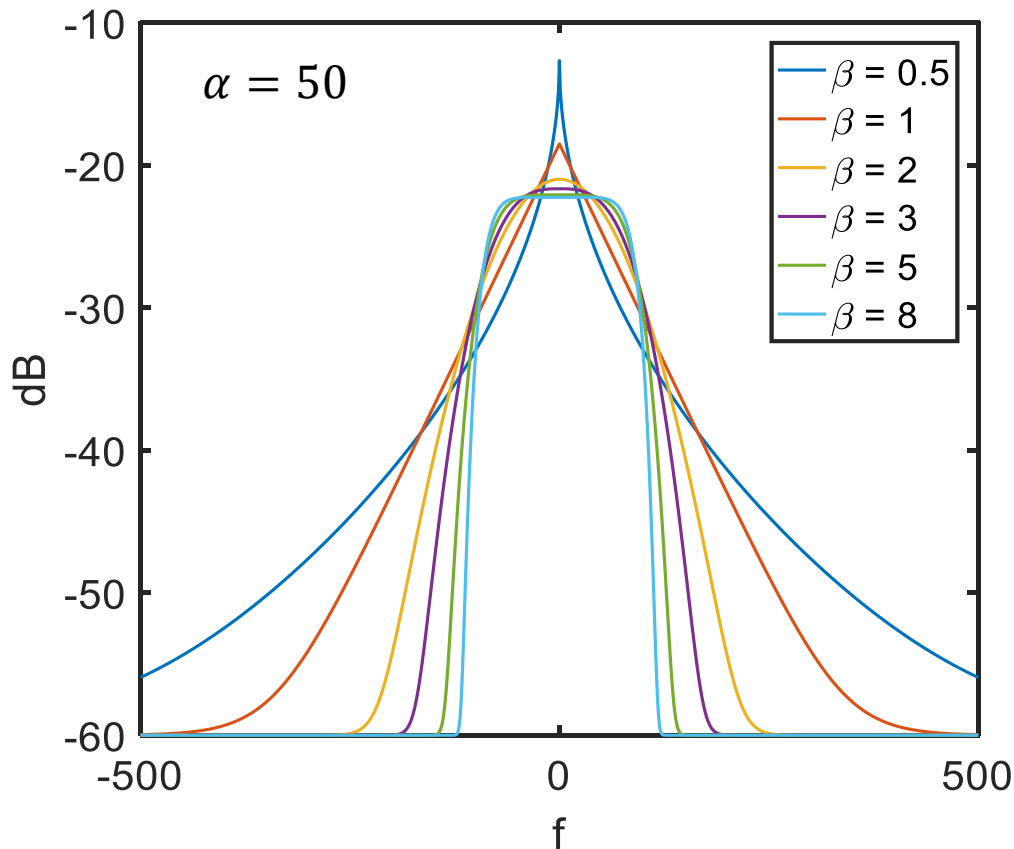

- Direct relation between  $\alpha$  and width (std deviation)
- Very peaked at low  $\beta$
- ➔  $\beta \leq 0.5$

