



**HAL**  
open science

## Effect of wall merging on a simplified building energy model: Accuracy vs number of equations

Fouquier Aurélie, Adrien Brun Brun, Ghjuvan Antone Faggianelli, Frédéric Suard

### ► To cite this version:

Fouquier Aurélie, Adrien Brun Brun, Ghjuvan Antone Faggianelli, Frédéric Suard. Effect of wall merging on a simplified building energy model: Accuracy vs number of equations. 13th Conference of International Building Performance Simulation Association, Aug 2013, Chambéry, France. cea-01614905

**HAL Id: cea-01614905**

**<https://cea.hal.science/cea-01614905v1>**

Submitted on 11 Oct 2017

**HAL** is a multi-disciplinary open access archive for the deposit and dissemination of scientific research documents, whether they are published or not. The documents may come from teaching and research institutions in France or abroad, or from public or private research centers.

L'archive ouverte pluridisciplinaire **HAL**, est destinée au dépôt et à la diffusion de documents scientifiques de niveau recherche, publiés ou non, émanant des établissements d'enseignement et de recherche français ou étrangers, des laboratoires publics ou privés.

See discussions, stats, and author profiles for this publication at: <https://www.researchgate.net/publication/272484760>

# Effect of wall merging on a simplified building energy model: Accuracy vs number of equations

Conference Paper · August 2013

CITATIONS

2

READS

68

4 authors, including:



[Aurélie Fouquier](#)

CEA LITEN

10 PUBLICATIONS 165 CITATIONS

[SEE PROFILE](#)



[Adrien Brun](#)

Atomic Energy and Alternative Energies Com...

19 PUBLICATIONS 47 CITATIONS

[SEE PROFILE](#)



[Ghjuvan Antone Faggianelli](#)

Université de Corse Pascal Paoli

13 PUBLICATIONS 21 CITATIONS

[SEE PROFILE](#)

Some of the authors of this publication are also working on these related projects:



experimental study of mantle convection [View project](#)



OMEGA (French ANR project) [View project](#)

All content following this page was uploaded by [Adrien Brun](#) on 06 May 2015.

The user has requested enhancement of the downloaded file.

# EFFECT OF WALL MERGING ON A SIMPLIFIED BUILDING ENERGY MODEL: ACCURACY VS NUMBER OF EQUATIONS

## ABSTRACT

In many countries, ambitious strategies and policies have been deployed to reduce building energy consumption. The method usually advised by standards is the building energy simulation with a large choice of software as TrnSys or EnergyPlus. These dynamic simulation tools are widely used and their results are reliable. However, their major drawback is their lack of flexibility and their complexity with respect to the source code. Moreover, these tools feature exhaustive descriptions of buildings' thermal behaviour, which can be time-consuming when such a degree of accuracy is not required. In this context, we chose to introduce our in-house model. Thus, we give in this article a brief description of this model. Then, we present a comparison and a validation of this model with the numerical software EnergyPlus on both small and high insulation monozone buildings. Moreover, we propose to study the effect of merging walls on the accuracy and the computation time.

## INTRODUCTION

A reliable building thermal model is an essential issue to obtain an optimal building energy management, fault detection and building diagnosis. Calibrating the Building Energy Simulation (BES) is one of the methods recommended by the three major standards (Committee IPMVP. 2001, Federal Energy Management Program. 1998, ASHRAE Guideline. 2012) in order to determine the proportion of effectively saved energy after retrofit. As a first step, parameters of the model are adjusted in order to match to a measured reference. Subsequently, calibrating BES estimate cooling and heating demands to maintain internal temperature under internal and external boundary conditions. Monthly or annual consumption is simply obtained by integrating the demand over a given period.

For the quantification of building's energy conservation benefits, (Raftery et al., 2011) recommended to set a building energy model as detailed as possible. Calibration of detailed Building Energy Models (BEM) such as EnergyPlus (US Department of Energy), TrnSys (University of Wisconsin), DOE-2 (Lawrence Berkeley National

Laboratory) is a great challenge since a large number of inputs are needed (over sixty variables for each thermal zone) (Déqué et al., 2000). While tuning such a model, the risk of error could become a penalizing factor. In a special validation test conducted on 12 participants (Guyon et al., 1997) reported a lot of errors using a single simulation model of a residential house with a consumption varying from -41% to +39% of the average value. In order to limit the dependence on personal analyst judgment, several calibration methodologies have been established (Raftery et al., 2011, Maile et al., 2010, Pedrini et al., 2002, Fumo et al., 2010).

Moreover, for control purpose and energy deletion strategies, the BES is generally achieved using simplified BEM. Most of the time, thermal physics is modelled using the electrical analogy. The main reasons are the conservation of the physical meaning (Berthou et al., 2011), a possible graphic representation, an easy resolution of the linear equations system and a short-term calibration can be used for long-term evaluation (Wang et al., 2006). Using such simplified physical behaviour, the building thermal response is obtained from limited set of capacity (C) and thermal resistance (R): 3R2C (Coley et al., 1996), 6R2C (Berthou et al., 2011), 8R3C (Hazyuk et al. 2012), 8R7C (Wang et al., 2006), 25R10C (Kummert et al., 2000). Thus, we noticed through the previous examples that the electrical analogy allows to choose the degree of complexity.

One specific requirement for the computation of the energy saving by the retrofit is the long-term model accuracy. Moreover, a specialized BEM should exclude all factors with negligible influence, which should limit the simulation time and the size of parameters search space for a realizable and robust model fitting. This requirement supposes that the accuracy for diverse modelling complexity has to be measured.

A technique to reduce the number of sensitive parameters and in the same manner, the computation time is to decrease the size of the geometrical system. Several ways are available to reduce the geometrical complexity:

- Merging identical thermal zones. This process is widely used in BES. Many BEM

software as EnergyPlus allow applying this zones merging quite easily. The new zones distribution is generally deduced from expert points of view.

- Reducing the discretization of the walls. An optimisation step is usually required to adjust the parameters of the reduced wall model (Fraisse et al., 2002, Wang et al., 2006).
- Merging several walls. It is probably the least explored method considering that it is often postulated that building zones need a detailed description especially for those with high insulation. However, we will see in this article that it is also a really accurate and direct way to reduce significantly the size of the system. For this reason, we focused our work on this method.

This work is a part of a larger internal research project devoted to Measurement & Verification tool development. The purpose of this paper is to illustrate the impact on a detailed BEM of some geometrical assumptions. The performance indicators will be the results accuracy and the simulation time. (Cho and al., 2008) have compared some simulations of a case study building with and without simplified box-shaped geometry and showed that deviations of the energy consumption results were less than 2%. In this study, we work on a box-shaped geometry and assess the impact of walls merging. Experiences are realized on a one-zone building with two level of insulation (low or high insulation). First, the most detailed in-house model is compared with reference detailed BEM (EnergyPlus) and in a second time, geometrical assumptions are tested.

## MODEL VALIDATION

### Model presentation

In the introduction, we showed the necessity to consider a complete model as a baseline one. Several software are nowadays available, but most of the time, their lack of flexibility and their complexity make difficult local modifications of the source code. In this sense, we implemented our in-house thermal model to keep a real flexibility of the numerical programs.

Considering that this model is intended to be coupled with an optimization algorithm to set unknown parameters, using few and simple equations is a valuable issue. Thus we model thermal heat transfer using the electrical analogy method that gives linear equations and so, facilitates drastically their resolution. To model the heat conduction through a wall, we represent the wall by a combination of electrical resistances and capacities. Resistances and capacities characterize respectively the wall's faculty to conduct the heat and the wall's ability to store energy and to give it back to its direct environment.

Other thermal mechanisms occurring in the building as the ventilation, the long-wave radiation or the convection are represented using constant thermal resistances. Finally, the short-wave radiation inside and outside the building, the radiation across the windows, the heating/cooling load and the internal load are taken into account as additional contributions. The internal mass is characterized by a capacity.

A major issue remains in the quantity and position of resistances and capacities needed to describe both the conduction and the storage into each wall. For this purpose, Laret et al. 1988 has proposed a criterion at the end of the 80's. It gives the minimum number of identical discrete elements for a given layer properties when using the finite conduction transfer method. The main disadvantage when using this criterion resides in the fact that it enforces a large amount of nodes for a wall especially when it is composed of several layers. Otherwise, the number of equations could be drastically reduced using simple 3R2C or 3R4C models (Fraisse et al., 2002) for a multi-layer wall but this simple model has to be associated with a calibration process in order to guarantee the model accuracy.

In the context of this article, we will consider a number of nodes consistent with the Laret criterion. This assumption enforces a proportional distribution of resistances into each layer of the wall except both surface capacities which are assumed to be quite low. Figure 1 and 2 show two kind of possible configuration of a wall: on the top, the most complex one considers the Laret criterion and on the bottom, the simpler one describes a wall by a 2R3C configuration.

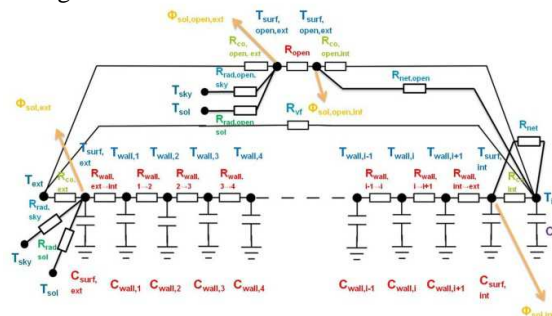

Figure 1: RC building model with wall model consistent with the Laret criterion.

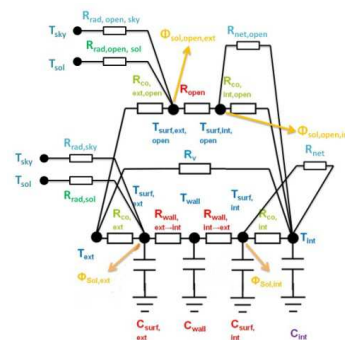

Figure 2: RC building model with 2R3C wall model

The main assumptions are summed up in Table 1.

Table 1: Main assumptions taken into account in the in-house model

PHENOMENON	ASSUMPTIONS
Conduction across the walls	Quasi 1D conduction – Description by a finite difference method
Interior convection along the walls	Linearization by assuming the convection factor $h_{conv,int}$ as a constant
Exterior convection along the walls	Linearization by assuming the convection factor $h_{conv,ext}$ as a constant
Interior LW radiation	Linearization by assuming the net flux factor $h_{net}$ as a constant
Exterior LW radiation	Linearization by assuming the LW factors (sky and ground) $h_{LW}$ depending on the surface temperature at the previous time
Interior SW radiation	The direct solar radiation passing through the window(s) is uniformly distributed over the floor and the diffuse solar radiation is distributed over all the walls (containing the floor) proportionally to the surfaces. The reflected radiations are also taken into account proportionally to the form factors
Exterior SW radiation	No specific assumptions.
Ventilation	The ventilation term depends on the dry air density calculated from the air zone temperature at the previous time

The model requires as input internal and external boundary conditions (internal charge and meteorological data), geometrical information and thermo-physical parameters such as resistances, capacities, ventilation, etc... The output of the model is the operative temperature but it can be quite simply reversed by enforcing the zone temperatures in order to determine for example the heating or cooling load.

### Case study

In order to validate the building thermal model previously described, the model accuracy has been evaluated considering EnergyPlus as reference. We have considered a simple and mono-zone building geometry whose dimensions are presented in Figure 3. The main façade is South exposed and its simple glass window ( $U=5.8 \text{ W}/(\text{m}^2\text{K})$ ,  $g=0.88$ ) represents 30% of the total facade surface. The door is North oriented and has following characteristics: width=1m x height=2.5m,  $U=0.8\text{W}/(\text{m}^2\text{K})$ . Several wall constructions have been tested and for each of them, the walls are assumed to be identical. It allowed testing different combinations with different levels of thermal inertia and insulation. Results from low and high external insulation on 20cm concrete structure, respectively named 1974 and quasi-passive, will be

presented. Characteristics of the walls are given in Table 2.

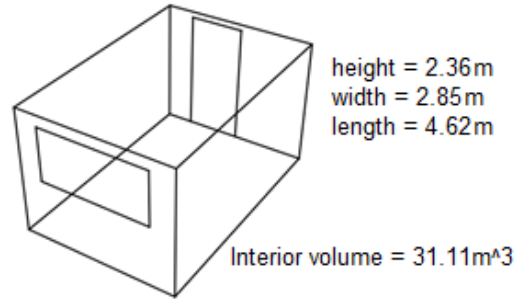

Figure 3: Case study geometry

### Simulation assumptions and parameters

In a benchmark phase, we tested the performance of our in-house model by comparing it with EnergyPlus software for both building types. We used the following assumptions:

- there is no heating or cooling system,
- infiltration and ventilation are combined. We consider a constant flow of fresh air of 1 ACH,
- an occupancy scenario is taken into account by imposing internal heat (sensible convective only) of 80 W at 8-12 am and 2-7 pm throughout the year,
- the heat transfer coefficients are constant. We set them (from inner to outer side) to  $3.29 \text{ W}/(\text{m}^2\text{K})$  and  $14.9\text{W}/(\text{m}^2\text{K})$  for verticals walls,  $1.78\text{W}/(\text{m}^2\text{K})$  and  $3.33 \text{ W}/(\text{m}^2\text{K})$  for the floor and  $4.59 \text{ W}/(\text{m}^2\text{K})$  and  $18.9 \text{ W}/(\text{m}^2\text{K})$  for the roof,
- the thermal bridges are not taken into account,
- the floor is above a crawlspace assumed to be at the outdoor temperature.

Yearly simulations were carried out with a 10 min time step for the yearly meteorological data of Chambéry (France).

Table 2: Thermo-physical characteristics (O : outer surface, I : inner surface)

	O	1 Insulation layer	2 Thermal mass layer	I
Material		Expanded polystyrene	Reinforced concrete	
Thickness (m) 1974/Quasi-passive		0.03 / 0.2	0.2/0.2	
$\lambda \text{ (W}/(\text{mK}))$		0.039	1.75	
$R \text{ (m}^2\text{K}/\text{W})$		0.77/5.13	0.11	
$\rho \text{ (kg}/\text{m}^3)$		25	2300	

$C_p$ (J/(kg.K))		1380	920	
$\epsilon$ (-)	0.9			0.9
$\alpha$ (-)	0.6			0.6

### Model validation

Accuracy of the presented model has been studied regarding simulation results of the EnergyPlus simulation software.

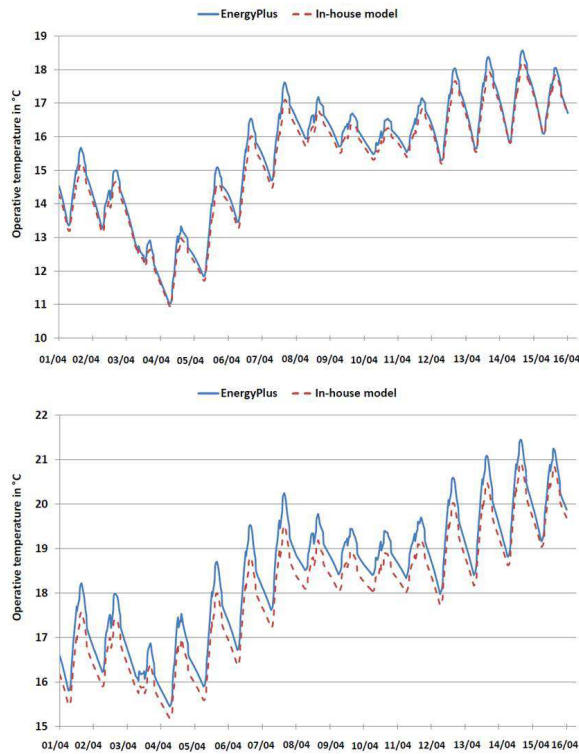

Figure 4: Operative temperature comparison for the 1974 (on the top) and quasi-passive (on the bottom) building within two weeks over the spring period

We validated our in-house model over a period of one year. However, for the results visualization, we represent them over only two weeks. Indeed, Figure 4 indicates the operative temperature over two weeks within a spring period for both 1974 and quasi-passive construction. The meteorological sequence has been chosen considering the variety of its solicitations (nearly constant and variable outdoor temperature). The dynamic and phase of our model are in great agreement with the reference, the maximal error during the entire year being always inferior to 0.9°C for both constructions.

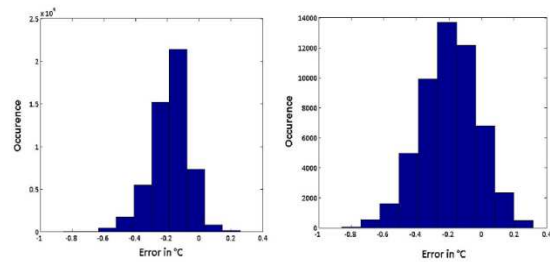

Figure 5: Histogram of errors during the entire year for the 1974's building on the left and the quasi-passive building on the right

Figure 5 presents the histogram of error. It shows the definite validity of our results. Moreover, this is supported by the fact that the daily average absolute error is always under 0.5 °C regardless of the configuration.

### WALLS MERGING IMPACTS

The benefit of developing a new in-house model resides in the fact that we are able to bring modifications or add new features to the program as free as possible. Thus, we implemented a new functionality to the code that allows reducing the geometrical complexity of the building and by this way, the computation time. Several ways are available to reduce the geometrical complexity:

- Merging identical thermal zones. This process is generally deduced from expert points of view.
- Reducing the number of nodes in the walls. An optimisation step is usually required to adjust the parameters of the reduced wall model (Fraisie et al., 2002, Wang et al., 2006).
- Merging several walls. Although this method has not been so much studied, it seems to be an accurate way to reduce significantly the size of the system. For this reason, we chose to develop it.

Thus, in this article, we focused our work on the walls merging. At this stage, the main difficulty is to determine walls that can be merged with a minimal effect on the simulation results. An interesting outcome would be to deduce some expert rules that could be used as decision support. With this intention, we chose to test the merging functionality on both building types described above, the "1974's" and "quasi-passive" building without any heating or cooling systems. The extensive variables as the wall surfaces or the inner and outer SW radiations are added to obtain the properties of the equivalent walls, while the equivalent intensive variables as the thermal coefficients or capacities are estimated from the surface weighted average. (We set up the cases studies with identical wall whatever the orientation in order to simplify the merging operation). We



describe in Table 3 the different configurations of geometry simplification.

## Results and discussion

For this study, we evaluated the monthly mean absolute errors by comparing the results of the walls merging versus those of the in-house complete model (no more EnergyPlus). They are presented in Figure 6 and 7.

Table 3: List of the configurations studied in the geometrical complexity reduction

N°	NB OF WALL ELEMENT	MELTING WALLS	SEPARATED WALLS
1	1 element	{N,S,E,W,F,R}	-
2	2 elements	{N,S,E,W,F}	{R}
3	2 elements	{N,S,E,W,R}	{F}
4	2 elements	{N,S,E,W,F,R}	{S}
5	3 elements	{N,S,E,W}	{R}, {F}
6	3 elements	{N,E,W,F}	{R}, {S}
7	3 elements	{N,E,W,R}	{S}, {F}
8	4 elements	{N,E,W}	{S}, {R}, {F}

Table 4: Results for 1974/quasi-passive constructions (MAX: maximal error, MAE, NEQ: number of equations). The reference model is the complete in-house model (with 6 elements). In red, the best configuration for the quasi-passive building, in blue, for the 1974's building and in bold, for both building types.

N°	MAX [°C]	ANNUAL MAE [°C]	NEQ [-]
1	0.5/0.6	0.19/0.27	17/23
2	0.8/0.6	0.42/0.35	31/43
3	0.3/0.4	0.15/0.19	31/43
4	0.5/ <b>0.2</b>	0.19/ <b>0.06</b>	33/ <b>45</b>
5	<b>0.1</b> /0.5	<b>0.04</b> /0.25	<b>45</b> /63
6	0.9/0.4	0.44/0.18	47/65
7	<b>0.2</b> / <b>0.1</b>	<b>0.19</b> / <b>0.09</b>	<b>47</b> / <b>65</b>
8	<b>0.008</b> / <b>0.003</b>	<b>0.003</b> / <b>0.001</b>	<b>61</b> / <b>85</b>
Ref	0/0	0/0	89/125

From these results, several observations appear. First, regarding the complexity of the system, Table 4 indicates the number of solved equations for each configuration (the equations number depends on the configuration because of the Laret criterion, which is different for each configuration). Given the fact that the number of equations for the complete formulation of the “1974’s” building and the “quasi-passive” building is respectively 89 and 125, the great interest of the geometrical reduction in term of computation time becomes obvious. Indeed, we note a factor 5 between the complete and the one-element configurations.

Secondly, we note that some configurations present good matching with the complete formulation.

Contrary to our expectations, increasing (or decreasing) the elements number does not necessarily lead to minimize (or to increase) the error. Indeed, we observe that the configuration 1 presents a better matching than the configuration 2. Thus, it shows that the choice of the merged walls is essential. Some specific rules seem to come out here. Especially, we observe that the configuration 8 is able to fit almost perfectly the complete model for both the “1974’s” and “quasi-passive” building. However, this geometrical reduction is not so interesting, the equations number being not so much reduced (reduced by only a factor 1.5). However, other configurations with fewer elements are able to give good fitting. For the “1974’s” building, we observe an influence of the floor on the monthly error when it is merged with other walls. Conversely, the configurations where the floor is isolated, present better matching. In contrast, the influence of the merged floor is less pronounced when the insulation is higher. Indeed, it seems easier to merge the floor in this case. Moreover, an influence of the South façade clearly appears for the quasi-passive building. Thus, the configuration 5 with isolated roof and floor appears as the best geometrical reduction for the 1974’s building according to a compromise between accuracy and computation time. Actually, it reduces the number of equations by a factor 2. In the same way, for the quasi-passive building, the configuration 4 with isolated South facade is the best one, reducing the number of equations by a factor 3. Note that the high insulation building needs a lesser number of elements than the small insulation one. However, a configuration common to both building types, the configuration 7 where the floor and the South facade are isolated, seems to keep also a good accuracy. This configuration decreases the number of equations by a factor 2.

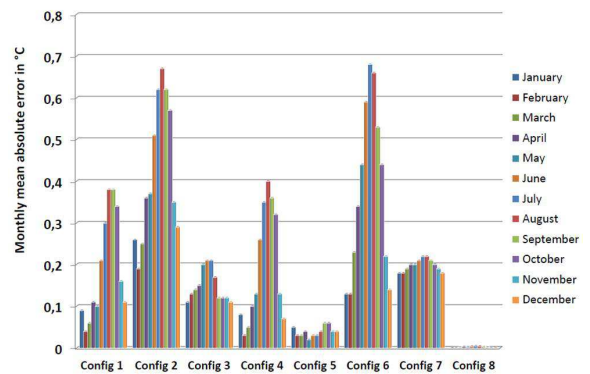

Figure 6: Histogram of the monthly mean absolute error for the 1974's building

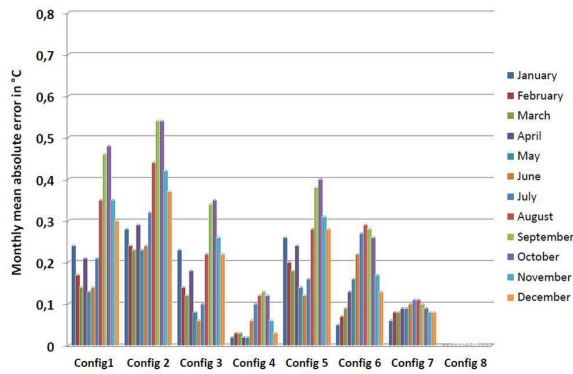

Figure 7: Histogram of the monthly mean absolute error for the quasi-passive building

Third, for both constructions we observe on Figures 6 and 7 a seasonal variation of the monthly error for the one equivalent wall model (configuration 1). In a calibrating phase, it is quite difficult to find constant parameters on the entire year considering the season variation. That is why the calibration phase is widely simplified by avoiding or at least reducing this variation. Moreover, we note that the increase of the elements number is not sufficient to decrease the seasonal variation. In this point of view, the choice of the merged walls seems again to be crucial. Nevertheless, the histograms show that some configurations are able to reduce this seasonal variation, some of them being compatible with both constructions as the configurations 7 and 8. Regarding respectively the “1974’s” and the “quasi-passive” building, the configurations 5 and 4 described above as the best configurations in term of accuracy and computation time present also almost uniform monthly errors.

Finally, we can conclude that the configuration with independent floor and roof (configuration 5) for small insulation building and the configuration with independent South facade (configuration 4) for high insulation building are able to keep a good accuracy, a significantly reduced computation time but also decrease the seasonal variation. Moreover, we saw also good results with configuration 7 with the advantage that it is compatible for both building construction. At last, the configuration 8 is the one presenting the best results in term of accuracy and error’s uniformity but the decreasing of the computation time is not sufficient.

## CONCLUSION

This study takes place in the context of the evaluation of energy saving after a building retrofit operation. Using Building Energy Simulation (BES) is one of the methods recommended by the standards IPMVP, FEMP and Guideline. However, this approach is a great challenge since the most appropriate Building Energy Simulation is widely detailed. Thus, users or optimizing tool had to set a large number of

parameters. Drawbacks of such detailed tools are an important risk of error due the complexity of the calibrating phase, which is generally time consuming. This phase generally combines manual and automatic methods, needs sensibility analysis in order to determine the most influent parameters. The automatic calibrating is time-consuming due to large size of the equations system.

However, simple Building Energy Models are generally used in the field of optimal building energy management system. Indeed, the few numbers of parameters that have to be tuned and the fast system resolution present some great interests for the optimization phase. Such models are designed for an easy calibration and sufficient accuracy whereas periodical fitting is needed. This is a specific limitation in our application where fitting the model is no longer possible after the retrofit operation.

Therefore, we suggested an evaluation of the relation between model complexity and large time-scale accuracy. Among different ways to reduce the number of equations, we focused our interest on the wall merging. First, we test the performance of our in-house model without approximation by comparing the results on two case studies with the BES EnergyPlus. Secondly, the complete six walls box-shaped geometry has been gradually decreased to one equivalent wall. We noted that some configurations present good matching with the complete formulation but contrary to our expectation increasing the complexity does not necessarily lead to minimize the error. Especially, we observed that the configuration 4 with the isolated South facade for the quasi-passive building and the configuration 5 with the isolated floor and roof for the 1974’s building are able to keep a good accuracy, a significantly reduced computation time but also decrease the seasonal variation.

Although both studied buildings are case specific, this work gives some orientations about the minimal number and orientation of walls element in order to limit the typical seasonal error of simple one equivalent wall BES. The next step of this work will be to verify if the calibration of a reduced configuration with few elements and an error nearly constant can effectively match measurements over a long period. It will be then possible to evaluate the energy savings over time due to the building retrofit operation.

## NOMENCLATURE

*BES* = Building Energy Simulation  
*BEM* = Building Energy Model  
*F* = Floor  
*LW* = Longwave  
*R* = Roof  
*NEQ* = Number of equation  
*MAE* = Mean Absolute Error



*SW* = Shortwave  
*N* = North facade  
*E* = East facade  
*S* = South facade  
*W* = West facade

## REFERENCES

- Hensen J. 2003. Preparation Guide and Submission Instruction for Building Simulation 2003 Conference, Eindhoven, The Netherlands.
- ASHRAE. 2002. Measurement of Energy and Demand Savings. ASHRAE Guideline.
- Berthou, Thomas, Pascal Stabat, Raphael Salvazet, and Dominique Marchio. 2012. Comparaison de modèles linéaires inverses pour la mise en place de stratégies d'effacement, AUGC
- Cho, Soolyeon, and Jeffrey S. Haberl. 2008. Validation of the eCalc Commercial Code-compliant Simulation Versus Measured Data from an Office Building in a Hot and Humid Climate. In Plano, Texas.
- Coley, D.A., and J.M. Penman. 1996. Simplified Thermal Response Modelling in Building Energy Management. Paper III: Demonstration of a Working Controller. Building and Environment
- Committee, IPMVP. 2001. International Performance Measurement and Verification Protocol: Concepts and Options for Determining Energy and Water Savings, Volume I.
- Déqué, F., F. Ollivier, and A. Poblador. 2000. Grey Boxes Used to Represent Buildings with a Minimum Number of Geometric and Thermal Parameters. Energy and Buildings
- Federal Energy Management Program. 1998. M&V Guidelines: Measurement and Verification for Federal Energy Projects.
- Fumo, Nelson, Pedro Mago, and Rogelio Luck. 2010. Methodology to Estimate Building Energy Consumption Using EnergyPlus Benchmark Models. Energy and Buildings
- Guyon, Gilles. 1997. Role of the Model User in Results Obtained from Simulation Software Program. In Prague.
- Hazyuk, Ion, Christian Ghiaus, and David Penhouet. 2012. Optimal Temperature Control of Intermittently Heated Buildings Using Model Predictive Control: Part I – Building Modeling. Building and Environment
- Kummert, Michaël, Philippe André, and Jacques Nicolas. 2001. Optimal Heating Control in a Passive Solar Commercial Building. Solar Energy
- Laret, Development of building dynamic multizone model for large-scale simulations, A Working conference for Users of Simulation Hardware, Software and Intellware. Proceedings of the User 1 Working Conference Ostend, Belgium, 6-8 Sept. 1988
- Lawrence Berkeley National Laboratory. DOE-2 Program. <http://www.doe2.com/>.
- Maile, Tobias, Martin Fischer, and Vladimir Bazjanac. 2010. A Method to Compare Measured and Simulated Data to Assess Building Energy Performance CIFE Working Paper #WP127. CIFE: Center for Integrated Facility Engineering.
- Pedrini, A., F.S. Westphal, and R. Lamberts. 2002. A Methodology for Building Energy Modelling and Calibration in Warm Climates. Building and Environment
- Raftery, Paul, Marcus Keane, and James O'Donnell. 2011. Calibrating Whole Building Energy Models: An Evidence-based Methodology. Energy and Buildings
- University of Wisconsin. TrnSys: Transient System Simulation Tool. <http://www.trnsys.com/>
- US Department of Energy. EnergyPlus Simulation Software.
- Wang, Shengwei, and Xinhua Xu. 2006. Simplified Building Model for Transient Thermal Performance Estimation Using GA-based Parameter Identification. International Journal of Thermal Science